

**POLON 4000**  
**INTERACTIVE FIRE DETECTION AND ALARM SYSTEM**

**TUN-4046**  
**ADDRESSABLE MULTI-STATE**  
**UNIVERSAL HEAT DETECTOR**

Installation and Maintenance Manual

IK-E283-001GB

IIIA Edition



The TUN-4046 heat detector covered by the present manual complies with the requirements of the following European Union Directives:

**CPD** 89/106/EWG on construction materials;  
**EMC** 2004/108/WE on electromagnetic compatibility.

The TUN-4046 Heat Detector has been approved with the EC-Certificate of Conformity No. 1438/CPD/0017 issued by the Scientific and Research Centre for Fire Protection (CNBOP) Józefów, Poland, an EU notified authority No. 1438, confirming its compliance with the requirements of the PN-EN 54-5:2003 standard.

The certificate may be downloaded from [www.polon-alfa.pl](http://www.polon-alfa.pl) web site.

 <b>1438</b>
Polon-Alfa Spółka z ograniczoną odpowiedzialnością Sp. k. 155, Glinki Street, PL 85-861 Bydgoszcz, POLAND 05 1438/CPD/0017
EN 54-5 <b>TUN-4046 Heat Detector</b> (addressable, multi-state, universal, detachable) Application – fire safety
Technical data - IK-E283-001GB manual

Read the manual carefully before the detector assembling and commissioning.

Any nonconformity with the instructions contained in the manual may be harmful or may cause violation of the law in force

POLON-ALFA bears no responsibility for any damage resulting from usage inconsistent with the manual.

A waste product, unsuitable for further use, shall be passed to a waste electric and electronic equipment collection point.	
---	---

**NOTE:** The manufacturer reserves the right to change specifications of products at any time without prior notice.

## 1 PURPOSE

The TUN-4046 programmable addressable microprocessor based heat detector is designed for detection of a fire hazard or fire appearance indication in closed premises, where during the first phase of fire an occurrence of temperature rise may be observed, or where ambient temperature may exceed a set fire danger level. It enables programming of appropriate actions in the place of installation that is it is possible to set up the detector's class and its operation way according to the PN-EN 54-5 standard. The TUN-4046 detectors are dedicated for interoperation with the POLON 4000 fire detecting and alarm system. They operate in addressable loop-shaped detection lines of that system. Every detector is equipped with a program controlled short circuit isolator.

## 2 TECHNICAL SPECIFICATIONS

Operating voltage	16.5 V ÷ 24.6 V
Maximum quiescent mode current consumption	≤ 150 μA
Detector class according to PN-EN 54-5 standard	A1, A2, B, A2S, BS, A1R, A2R, BR
Maximum installation height *)	7.5 m
Maximum supervised area *)	30 m <sup>2</sup>
Other parameters	acc. to PN-EN 54-5 standard
Allowable relative humidity	up to 95 % at 40 °C
Minimum operating temperature	-25 °C
Dimensions (without base)	∅ 115 mm x 43 mm
Mass (without base)	0.2 kg
Standard colour	white
Address coding method	programmable at control panel

\*) TUN-4046 detectors should be installed (height, arrangement) in accordance with the Scientific and Research Centre for Fire Protection (CNBOP) design guidelines.

## 3 SAFETY CONDITIONS

### 3.1 Repairs and maintenance

Any maintenance works or periodic inspections shall be executed by skilled personnel employed by companies authorised and trained by POLON-ALFA.

Any repairs must be carried out by the manufacturer. POLON-ALFA bears no responsibility for the operation of any apparatus being repaired by unauthorised personnel.

### 3.2 Works at height

Any detector installation works carried out at height must be executed with particular care utilising tools and machinery in good working condition.

Special attention shall be given to stability of ladders, elevators, lifts, etc.

Any electric tools shall be used strictly obeying the safety rules stated in instruction manuals by manufacturers.

### 3.3 Anti-dusting eye protection

It is obligatory to use protective anti-dusting glasses and masks during detector installation works that produce high amount of dust, such as hole drilling in ceilings.

## 4 DESIGN DESCRIPTIONS

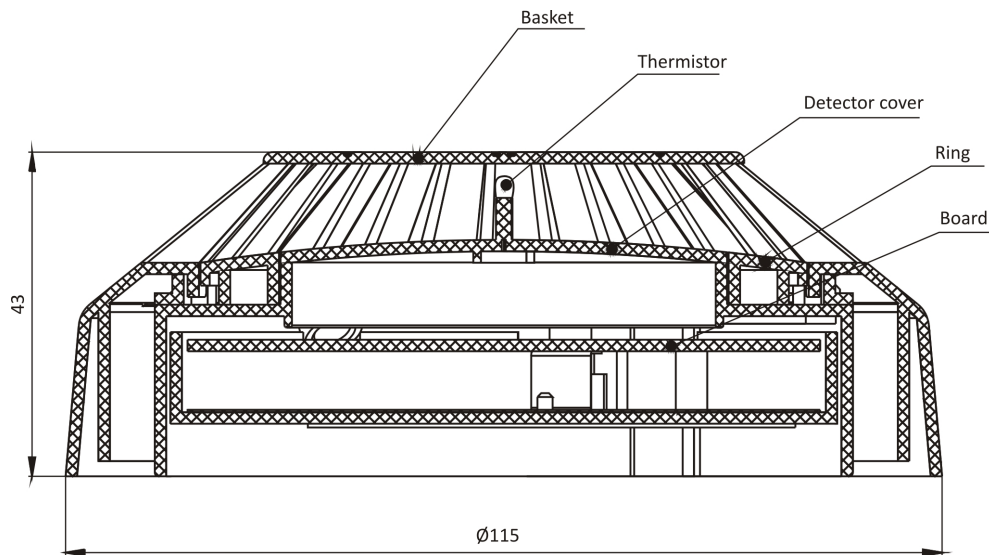

Fig. 1. TUN-4046 detector overall view

The detector mechanical construction is shown in Fig. 1. Its basic element is a detecting module consisting of a temperature-sensitive resistor (thermistor). The thermistor, protruding above the detector casing, is located in the central point and protected against mechanical damages by a basket. The detecting module is fastened to a printed board that contains all electronic elements and the detector operation monitoring processor. The detector shape and construction enable free ambient air flow and its direct impact on the detecting circuit. The whole structure is placed in a white plastic housing containing a basket, detector cover, ring, and screen.

The TUN-4046 detector is installed in the G-40 base where detection line cables are connected to.

## 5 PRINCIPLE OF OPERATION

The TUN-4046 heat detector reacts to a rise of temperature occurring during initial phase of fire. The detector operates in two ways:

- as a fixed temperature detector – after exceeding its set-up temperature activation threshold, pursuant to its given class;

- as a rate-of-rise heat detector - when a rapid rise of temperature exceeds the level determined for the detector, pursuant to its given class.

A microcontroller monitors the detector operation, collecting data concerning the ambient temperature around the detecting circuit, carries out measurement analyses, makes decisions, and is responsible for communication between the detector and the fire detection control panel.

The detector alarm mode is signalled with flashing light of a red diode which is located in the detector casing. The indicator enables quick location of the activated detector and is helpful during periodic detector operation inspections. In case the detector is poorly visible or installed in hardly accessible place, it can be furnished with an additional optical actuation indicator that should be mounted in an accessible and visible place.

Communication between the POLON 4000 system fire alarm control panel and the TUN-4046 detectors is provided using a two-wire addressable detection line. A unique, fully digital communication protocol enables passing any information from the control panel to the detector and inversely.

Apart from sending to the control panel the temperature value estimation and a tendency of its change, the detector can transmit – on the control panel request – the current analogue value.

The detector operation controlling microprocessor monitors its basic systems proper operation and, in a case of irregularity, delivers relevant information to the control panel.

The detector is equipped with an internal short circuiting insulator that cuts off an efficient part of detection line from the neighbouring shorted section what enables the detector further undisturbed operation. The alarm mode is indicated with pulse red light emitted by the signalling diode. The fault mode, technical alarm, and short circuit isolator actuation are signalled with yellow flashes of the illuminating diode.

The detector is furnished with a possibility to choose a way of reaction in the installation place, pursuant to a given class. It is the TUN-4046 heat detector so called operation mode. A choice of one of the following classes: A1, A2, B, A2S, BS, A1R, A2R or BR is made from the control panel level. The detector with the class set as A2S, BR operates only in a fixed-temperature mode. All operation modes are accordant with the PN-EN 54-5 standard. The detector operation modes (besides alarm variants in the control panel) provide the user with an opportunity to adapt, in the best way, the system operation characteristic to the determined environment conditions.

The TUN-4046 programming procedure is described in the POLON 4000 system programming manual.

## 6 OPERATION AND SERVICING CONDITIONS

During the detectors operation it is necessary to avoid creation of dew or rime on the detector surface as well as to protect against excessive dust contamination.

**In case of any repair works the detector should be taken out (with consideration of p. 3.1) or protected with a provided-for-this-purpose cover. Such covers can be obtained from an installer or purchased from the manufacturer. If the detector is taken out, the base should be protected against painting with a help of painting tape. Detectors which are damaged during renovation or painting works due to a fault of executing persons (e.g. painted detector casing) are not subject to warranty repairs.**

The TUN-4046 should be subjected to periodic inspection according to the PKN-CEN/TS 54-14:2006 which is carried out in order to confirm the detector proper operation and its appropriate interoperation with the control panel. The inspection should be conducted at least once in 6 months.

Such an operation test can be carried out using a heat detector tester.

A thermistor fault (short circuit or disconnection) is revealed by the detector and a fault signal is sent to the control panel. Any damaged detectors should be passed to the manufacturer (Polon-Alfa, 155, Glinki Street, PL 85-861 Bydgoszcz, Poland) for repair.

**Note:** The detector dismantling by the user, installer or maintenance technician is forbidden! Only a skilled installer is authorised to mount the detectors.

## 7 DETECTOR INSTALLATION

The TUN-4046 heat detectors are installed (height, arrangement) according to the Scientific and Research Centre for Fire Protection guidelines. They operate in loop-shaped lines, in loop-shaped lines with straight branches, or in radial detection lines of the POLON 4000 system (compare the POLON 4900 control panel manual).

The detectors are installed in the 40 model range bases. A detection line connection method is presented in the G-40 base installation and maintenance manual. An additional optical alarm signal of a detector or a group of detectors can be obtained by connecting the WZ-31 alarm actuation indicator.

Alarm system cables are routed in accordance with low voltage system (below 42V) regulations as in force.

**ATTENTION – The detectors should not be installed in premises of corrosive atmosphere that contains caustic gases and vapours as well as high dust level. Steam condensation on the detectors is inadmissible.**

## 8 STORAGE AND TRANSPORTATION

### 8.1 Storage

The TUN-4046 detectors should be kept in closed rooms free of any caustic gases and vapours at the temperature between +0 °C and +40 °C, and relative humidity not exceeding 80 % at +35 °C.

In the time of storing, the detectors should not be exposed to either direct sunlight or heat from heating equipment.

The detectors storage period in transportation packing should not exceed 6 months.

### 8.2 Transportation

The TUN-4046 detectors can be carried in closed transport means spaces, in packing that meets the requirements of transportation regulations in force. The temperature during transportation should not be lower than -40 °C and higher than +70 °C, and relative humidity should not be higher than 95% at + 45 °C or 80% at +70 °C.

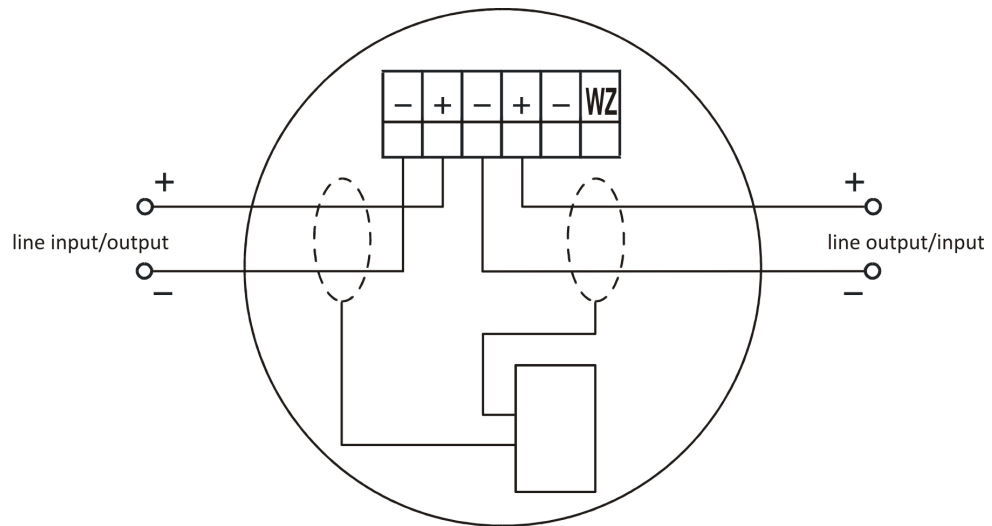

Fig. 2 Clamps of base interoperating with TUN-4046 plug