

AUTONOMOUS GAS DETECTORS TYPE ASG-2000

Installation and Maintenance Manual
IK-E366-001GB

Edition IA

Autonomous gas detectors type ASG-2000, subject to these Instructions, meet the essential requirements of the following Regulations of the European Parliament and of the Council (EU) as well as European Union directives:

EMC Directive (EU) 2014/30/EU on electromagnetic compatibility.

LVD Directive (EU) 2014/35/EU concerning electrical equipment intended to be used within certain voltage limits.

The Declaration of Conformity No. 1/E366/2017/PL was issued for autonomous gas detectors type ASG-2000.

The Declaration of Conformity is available at www.polon-alfa.pl .

Prior to starting assembly and operation, please read the contents of this manual.

Failure to follow the instructions of this manual may be dangerous or cause violation of applicable regulations.

The Polon-Alfa manufacturer is not liable for damages resulting from use contrary to this instruction.

A worn out product, not suitable for further use, should be transferred to one of the entities dealing with the collection of waste electrical and electronic equipment.



Note - The manufacturer reserves the right to introduce changes into this instruction

1. INTENDED APPLICATION.

Detectors type ASG-2000 are designed to detect flammable and toxic gases in public facilities, especially in underground garages and boiler rooms. They have a replaceable sensor module with 3 alarm thresholds. The detectors enable the early start of ventilation, preventing the accumulation of gas in quantities threatening health and life, and the activation of warning signalling system.



!!! PLEASE NOTE

ASG-2000 type detectors are not intended for use in potentially explosive atmospheres.

Thanks to the built-in temperature compensation, detectors can work in changing environmental conditions.

Information about the installed sensor module together with the alarm threshold values can be found on the detector housing.

Table 1: Selection of ASG-2000 detectors.

Model	ASG-2001	ASG-2001HV	ASG-2002	ASG-2002HV	ASG-2003	ASG-2003HV
Detected gas	CNG (natural gas) (selective methane)		LPG (propane butane)		CO (carbon monoxide)	
Sensor module	MSG-6001		MSG-6002		MSG-6003	
Type of sensor	semiconductor		semiconductor		electrochemical	
Power supply	9÷30 V DC	230 V AC	9÷30 V DC	230V AC	9÷30 V DC	230V AC

2. THREATS RELATED TO GASES.

CO - carbon monoxide - colourless and odourless gas, undetectable by the senses. Slightly lighter than air, very easily mixed with it. Carbon monoxide as a product of incomplete combustion is practically always present in exhaust gases of motor vehicles and in boiler rooms. It is perfectly absorbed into the body (better than oxygen) permanently binding to haemoglobin, which may result in serious hypoxia.

Table 2: The effect of carbon monoxide on humans according to CIOP-PIB¹.

The concentration of CO in the air	ABSOPTION TIME AND observed SYMPTOMS OF POISONING
~ 200 ppm	slight headache after a few hours
~ 400 ppm	headache, nausea, vomiting, muscle weakness, malaise after 1 to 2 hours
~ 800 ppm	circulatory collapse, loss of consciousness after 2 hours
~ 1600 ppm	circulatory collapse within 20 minutes, risk of DEATH after 2 hours
~ 3400 ppm	collapse after 5-10 minutes, the risk of DEATH after 30 minutes
~ 7000 ppm	collapse after 1-2 minutes, risk of DEATH after 10 -15 minutes
~ 13000 ppm	DEATH after 1 to 3 minutes!

LPG (autogas) - the most popular gas fuel in vehicles with an internal combustion engine. A mixture of combustible hydrocarbons, mainly propane and butane. The lower explosion limit of butane is 1.4% and propane 1.7%. It is much heavier than air, which means that it will be lying down in all depressions of the area, basements, car inspection pits, etc. The danger associated with LPG is primarily its explosiveness.

CNG (compressed natural gas) - an increasingly popular and cheap fuel for delivery vehicles and public transport. The main component is methane - gas much lighter than air, which means that it can lie under the ceiling of the room. The lower explosion limit for methane is 4.4%.

3. TECHNICAL DATA.

Table 3: Technical parameters.

Parameter	ASG-200x	ASG-200xHV
Power supply voltage	9÷30 V DC	230 V AC±10%
Power consumption	max 120 mA@12 V max 60 mA@24 V	max 3 W
Alarm thresholds	ASG-2001: A1 = 10% A2 = 20% A3 = 30% LEL methane (selective) ASG-2002: A1 = 10% A2 = 20% A3 = 30% LEL propane-butane (50/50) ASG-2003: A1 = 30 ppm CO (TWA 15 min.) A2 = 60 ppm CO (TWA 15 min.) A3 = 150 ppm (exceeded for at least 60 s) according to PN-EN 50545-1	
Gases interfering the measurement	ASG-2001: hydrogen, ethanol, oxygen deficiency ASG-2002 : methane, hydrogen, ethanol, oxygen deficiency ASG-2003 : hydrogen, ethanol at a low extent	
Working conditions	-20 ÷ 50°C humidity 10-90%	
Storage conditions	0 ÷ 40 °C humidity 10-80%	
Protection level	IP54 (in the recommended mounting position)	
Housing material	ABS/PC	
Cable connectors (cable diameter)	M16 gland (5÷10 mm)	
Load capacity of relay outputs	3 A/30 V DC 3 A/250 V AC Limitation of common terminal 3A (due to internal connections).	
Dimensions (with connectors)	80x216x68 mm	
Mass	<0.3 kg	<0.35 kg
Frequency of service inspections	Recommended in 3 months (maximum 12 months)	
Sensor life time.	about 10 years	

4. STRUCTURE DESCRIPTION.

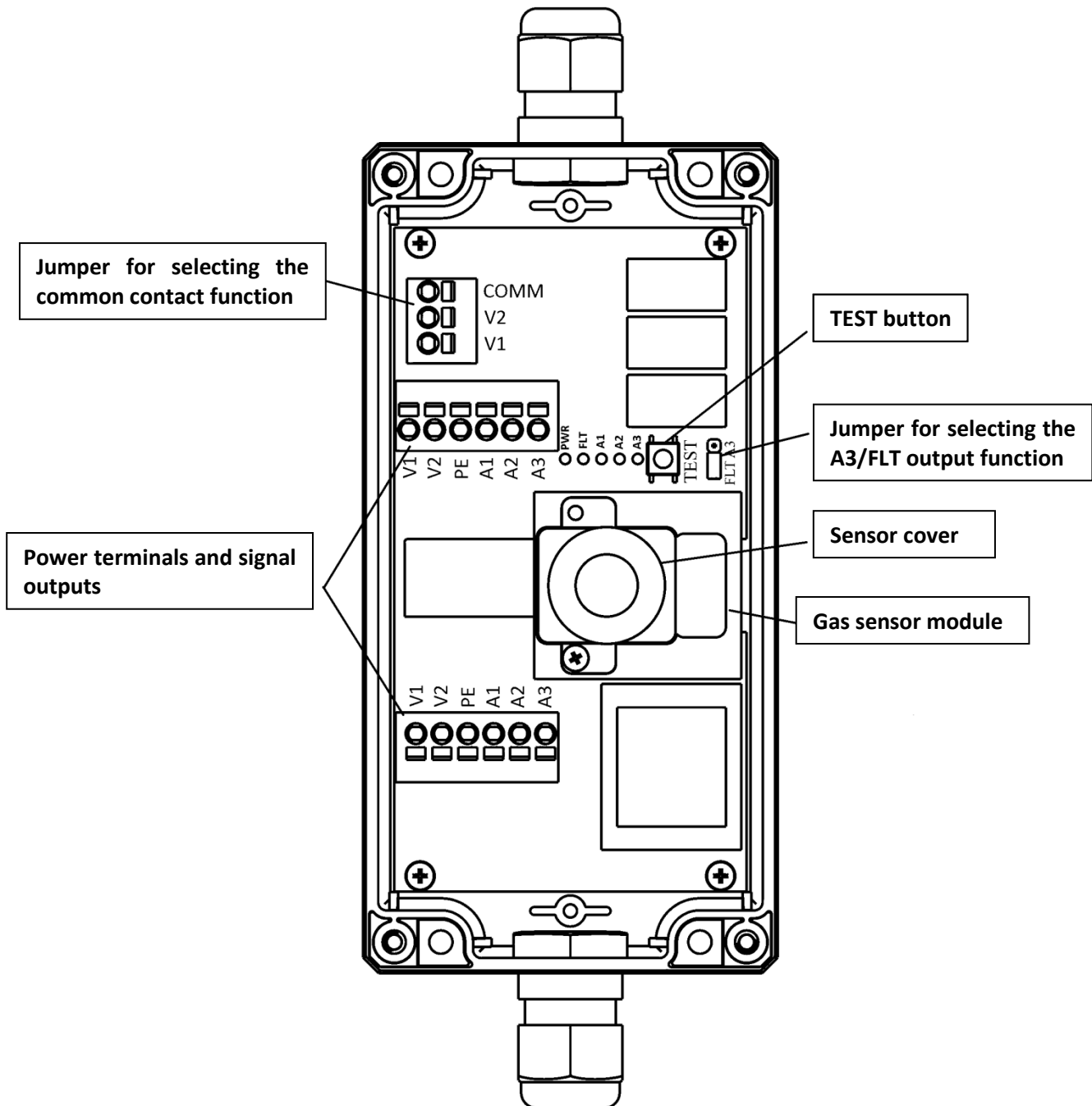

Figure 1 The detector after removing the cover.

Figure 1 shows the interior view of the detector. The detector is equipped with two installation connectors that allow the use of cables such as wire or cord with a cross-section of 0.25 to 2.5 mm². These connectors are used to connect the power supply and the detector signalling outputs. The second connector has the same function, which enables the user to connect another detector without the need for a junction box.

Markings related to the power contacts are located on the sticker between the connectors and are presented in the table below.

Marking of the contact	ASG-2000 Power supply 9 ÷ 30 V DC	ASG-2000HV Power supply 230 V AC
V1	+	L
V2	-	N

The detector has a contact selection terminal for common relay contacts, it is possible to select three functions:

- common contacts connected internally to terminal V1,
- common contacts connected internally to terminal V2,
- connection of an external signal to the COMM contact.

The default setting is to connect the common relay contacts to the V1 contact. The signalling diodes are marked in Figure 1. The ASG-2001 and ASG-2002 detectors on the sensor module include a cover with an anti-dust filter that protects not only against dust but also against small insects. In the ASG-2003 detector, the sensor is insulated directly to the ventilation element.

	<p>!!! PLEASE NOTE</p> <p>The total value of the loads of all relays is up to 3 A. This limitation results from the internal connections of the detector.</p>
---	--

5. FUNCTIONAL DESCRIPTION.

Detectors in their principle of operation use the phenomenon of gas diffusion in the environment. The ventilation element allows gas to enter the detector and reach the sensor. The microprocessor measurement system continuously analyses the concentration of the measured gas and compares it with the value of the appropriate alarm threshold. In the case of alarm thresholds expressed in instantaneous values, a false alarm filter (shorter than 15s) has been added. The measuring system also performs temperature compensation allowing the use of detectors in a wider temperature range. After connecting the power supply, the detector is in the state of heating of the sensor, lasting 1 minute, during which the sensor pre-conditioning is conducted. The semiconductor sensors achieve their full measurement efficiency after not less than 48 hours of uninterrupted power supply.

Table 4 describes the condition of the relay outputs depending on the detector status.

	<p>!!! PLEASE NOTE</p> <p>No power supply if the A3/FLT contact function of the A3 alarm function is selected by means of a jumper, this output is activated (relay contacts closed).</p>
---	--

Table 5 describes the status of LEDs during correct operation, a Table 6 describes the status of the FLT diode in various emergency states.

Table 4: Status of relay outputs depending on the condition.

STATUS	ALARM CONTACT OUTPUTS				
	Terminal A1	Terminal A2	Terminals A3/FLT		
Position of the functional jumper			A3	FLT	none
SUPERVISION	open	open	open	open	open
ALARM LEVEL 1	CLOSED	opened	opened	opened	opened

STATUS	ALARM CONTACT OUTPUTS				
	Terminal A1	Terminal A2	Terminals A3/FLT		
ALARM LEVEL 2	CLOSED	CLOSED	opened	opened	opened
ALARM LEVEL 3	CLOSED	CLOSED	CLOSED	opened	opened
DETECTOR'S FAILURE	opened	opened	opened	CLOSED	opened
SENSOR'S FAILURE	opened	opened	opened	CLOSED	opened
POWER FAILURE	opened	opened	CLOSED	CLOSED	CLOSED
NO SENSOR MODULE	opened	opened	opened	CLOSED	opened

Table 5: Description of the detector status indication in the state without failure.

Detector status	LED power supply (PWR)	LED A1 A2 A3
Normal condition	It shines constantly	Off
Normal condition - heating	Flashing at frequency of 1 Hz	Off
no sensor module	Off continuously	Off
A small concentration of gas was detected	Switches off every 2.5s	
Alarm condition A1	Switches off every 2.5s	A1 constantly on
Alarm condition A2	Switches off every 2.5s	A1 and A2 constantly on
Alarm condition A3	Switches off every 2.5s	A1, A2 and A3 are constantly on

Table 6: Description of the detector status indication in the emergency condition.

DETECTOR STATUS	LED failure (FLT)	COMMENTS
Recommended calibration	It is constantly on	Occurs one month before the calibration validity period expires
Sensor fault	It is constantly on	

6. INSTALLATION OF DETECTORS.

6.1. Place of installation.

The place of installation has a significant impact on the detector's work. The detector should be mounted:

- as close as possible to the potential source of gas - no more than 9 m,
- away from ventilation openings, doors or windows,
- in a place with free flow of ambient air,
- in a place with no sun exposure, far from heat sources,
- in a place not impacted by mechanical damage, vibrations and strong electromagnetic fields,
- in a place not impacted by direct influence of outside air, water vapour, liquids and car exhaust, exhaust gases from furnaces and dust.

CO detectors should be mounted at a height of about **1.5-2 m** (i.e. at the height of the head of a person of an average height).

LPG detectors should be mounted at a height of **15 cm** away from the hollows in the ground.

CNG detectors should be mounted at a height **not lower than 30 cm** below the ceiling or on the ceiling.

6.2. Mounting position.

Detectors of the ASG-2000 series are recommended to be installed in a vertical position with the gas inlet down, this position guarantees the best protection against dust and splashes of water. In the case of methane detectors, due to the mounting height, a horizontal position (increased susceptibility to dust accumulation in the gas inlet element) or ceiling mounting is possible although not recommended. Installation with the gas inlet directed upwards is not allowed, in this position the detector is exposed to water ingress and excessive accumulation of dust in the gas inlet. Mounting positions are shown in Figure 2.

For propane-butane detectors, due to the low mounting height in places exposed to mechanical damage, it is recommended to use a suitable cover.

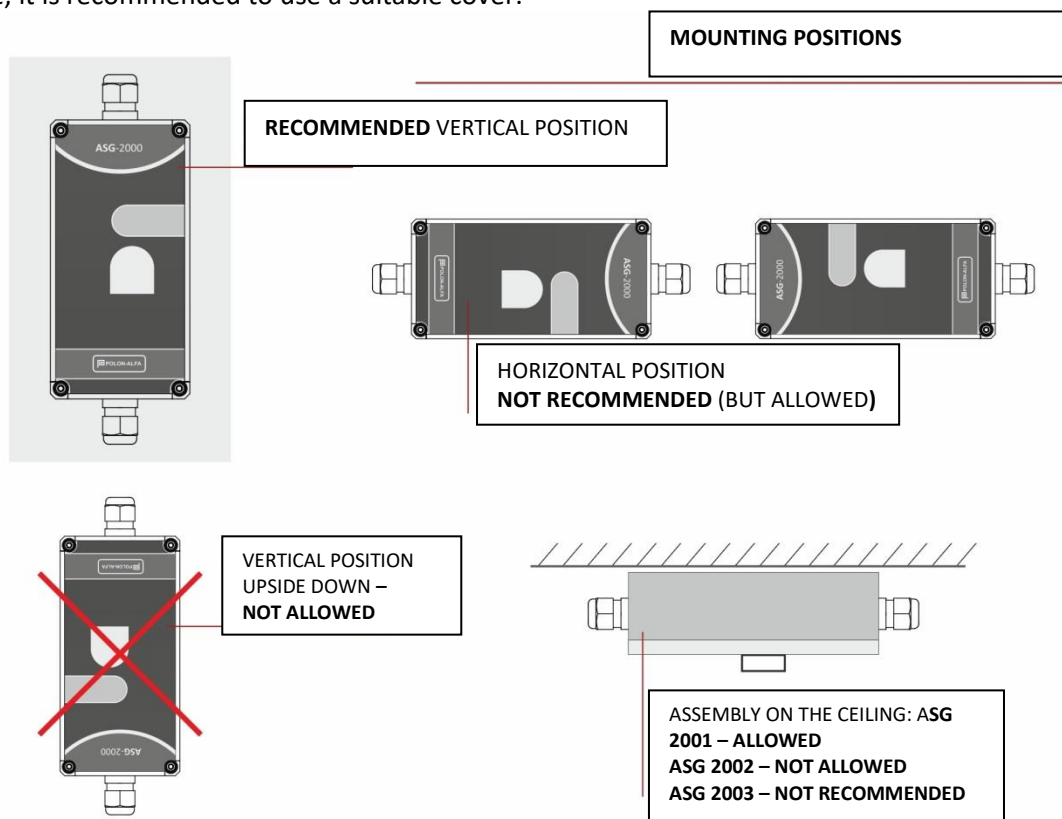

Figure 2. Mounting position.

6.3. Detector installation.

	<p>!!! PLEASE NOTE</p> <p>All work related to the installation of detectors should be carried out with the disconnected power supply.</p>
--	--

Before mounting, check the validity of the calibration certificate.

Remove the detector cover and the sensor module to protect it from dust. Mount the detector to the ground with 4 wall plugs.

Terminal block connectors allow the use of multiple wire cables like wire and cord with a cross section between 0.25 and 2.5 mm². The diameter of the cable is limited by the cable glands used and amounts to 5 ÷ 10 mm. The cable ends must be insulated to a length of 8 mm.



!!! PLEASE NOTE

Before connecting the power supply, make sure that all detectors have the same common contact function selected; in the case of incorrect settings, there is a risk of a short circuit during the test, an alarm condition or a fault.



!!! PLEASE NOTE

The supply circuit and the control circuit must be protected with over-current fuses.

After connecting the power supply and heating all sensors, you can perform the installation test according to the procedure 8.1. After the positive test result, the detector covers can be mounted, making sure that the sensor covers are mounted and located in the correct position (applies only to detectors ASG-2001 and ASG-2002). Lack of the sensor cover reduces the protection of the housing to IP43, and detector operation without the sensor cover is not allowed. For ASG-2003 detectors, check whether the sensor insulation has been damaged.

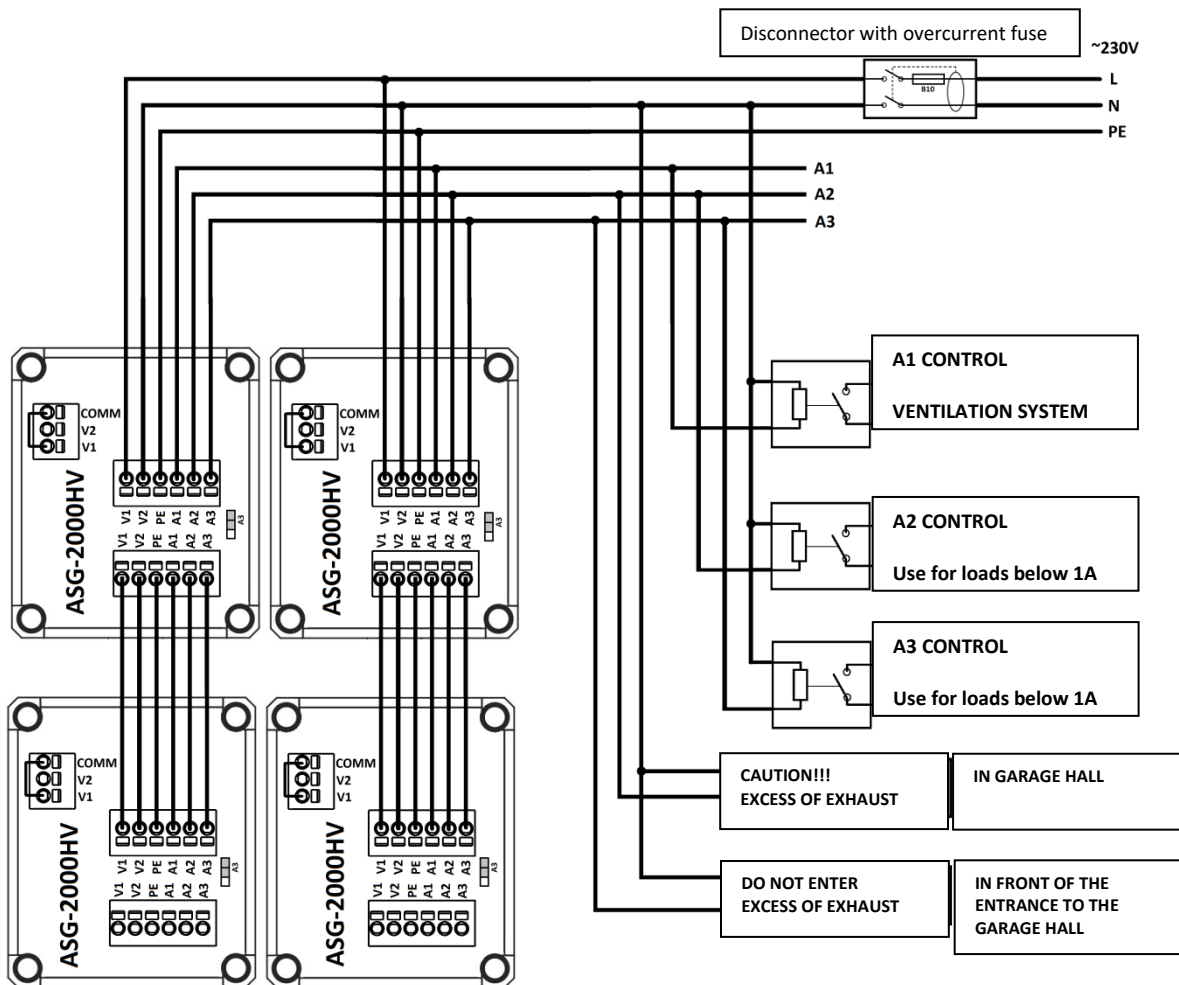

Figure 3. Scheme of installation of the 3-threshold system, control wires connected to the phase wire.

7. OPERATION AND SERVICE CONDITIONS.

In accordance with the Regulation of the Minister of Interior and Administration of April 21, 2006 on the fire protection of buildings and other construction facilities 2006 No. 80, item 563, technical inspection and maintenance of gas detection systems ought to be conducted at least once a year.

Periodic inspection is recommended to be carried out once every 3 months and after the occurrence of:

- extreme operating conditions, i.e. high dust level, temperatures beyond the allowable range, high concentration of detected gas,
- long-lasting alarm condition,
- after a long power supply interruption,
- after renovation work.

Periodic inspection consists in:

- checking the patency of the gas sensor cover and the condition of the seals,
- periodic testing of detection functions, see 8.2.

In the case of renovation works, ASG-2000 detectors must be turned off and sealed with a foil. Any solvent or silicone fumes are very harmful to the sensors.

As semiconductor sensors increase their sensitivity over time, it is recommended to calibrate the sensor at least once every 3 years and in the case of frequent reactions to too low gas concentrations. Electrochemical sensors decrease their sensitivity over time, and the long term of very low humidity level or very high humidity level will have an effect on changing the sensitivity. It is recommended to calibrate devices at least every 3 years.



!!! PLEASE NOTE

The expiration of the calibration validity period is indicated by a fault.

If you need to calibrate the sensors, the sensor module should be removed and sent back to the manufacturer. The return of the module is the fastest and most economically justified way to ensure full correctness of the sensor's operation. The calibrated sensor module will be sent back with a new calibration certificate and a sticker informing about the type of sensor and the date of the next calibration, which should be placed on the detector housing in the previous place.

7.1. Sensor module replacement.

Disassembly of the sensor module:

- disconnect the power supply,
- disassemble the detector cover,
- unscrew the sensor cover if present,
- grip the sensor's plate with your fingers and gently pull it out,
- mount the detector cover.



!!! PLEASE NOTE

Lack of the sensor module will reduce the protection of the enclosure to IP43.



!!! PLEASE NOTE

Connecting the power supply to the detector without the sensor module will result in the FLT diode indication being signalled, and if the fault function is selected with the jumper for selecting the A3/FLT output function, this output will be activated.

Installation of the sensor module:

- disconnect the power supply,
- mount the sensor module making sure it is properly mounted (all pins are in the sockets),
- screw in the sensor cover, if present,
- mount the detector cover so that the sensor's inlet surface is under the foam seal of the ventilation element,
- turn on the power supply.

After turning the power on, the POWER diode in the ASG-2000 detectors should flash for 60s, signalling that the sensor is heating up and then lighting up continuously.

8. TESTING DETECTORS.

8.1. Installation testing.

The ASG-2000 detectors allow you to test the correctness of the installation. For this purpose, hold down the TEST button until the PWR LED starts flashing. During the test, the relays are released in sequence as shown in Table 7.

Table 7: The detector test procedure.

No.	Time [s]	STATUS OF RELAYS			DESCRIPTION
		A1	A2	A3/FLT	
1	0-10	0	0	0	A1 LINE TEST
2	10-20	1	0	0	
3	20-30	0	0	0	A2 LINE TEST
4	30-40	0	1	0	
5	40-50	0	0	0	A3/FLT LINE TEST (jumper from A3 position)
6	50-60	0	0	1	
7	60-70	0	0	0	A3/FLT LINE TEST (jumper in FLT position)
8	70-80	0	0	1	

8.2. Test of the detection function.

Using a suitable test cap at a flow rate of 0.5 l/min, provide the test gas:

- for ASG-2003 containing 100 ÷ 200 ppm CO for a time suitable for triggering alarm A1 or A3,
- for ASG-2001 and ASG-2002 containing > 20% LEL of gas detected until the alarm is triggered.

When detecting a small amount of gas, the POWER diode is permanently lit with short stops every 2.5 seconds, allowing the test to be performed in a shorter time and not subjecting the sensors to a significant concentration of gas.

9. SAFETY CONDITIONS.

9.1. Repairs and maintenance.

Maintenance and periodic inspections must be carried out by authorized personnel of companies authorized or trained by Polon-Alfa.

All repairs must be made by the manufacturer.

Polon-Alfa shall not be liable for the operation of equipment maintained and repaired by unauthorized personnel.

9.2. Work at heights.

Work at heights related to the installation of detectors should be carried out with extreme caution when using efficient equipment and tools.

Special attention should be paid to the stability of ladders, lifts, etc.

Power tools should be used with observance of the conditions of their safe operation specified in the relevant manufacturer's instructions.

9.3. Eye protection against dust.

During work that causes the formation of a large amount of dust, especially drilling holes in the ceilings to attach detectors, use safety goggles and dust masks.

10. STORAGE AND TRANSPORT.

10.1. Storage.

The detectors should be stored in closed rooms where no vapours or caustic gases are present, the temperature is in the range from 0° C to +40° C, and the relative humidity does not exceed 80% at +35° C.

During storage, the detector should not be exposed to direct sunlight or heat from heating devices.

The period of storing the detector in the transport packaging should not exceed 6 months.

10.2. Transport.

Detectors should be transported in closed spaces of means of transport, in a packaging that meets the requirements of applicable transport regulations. The temperature during transport should not be lower than -20° C and higher than +50° C, and relative humidity not greater than 95% at +45° C or 80% at +50° C.

IK-E366-001GB/IA/01.2019/