

TUN-38Ex Intrinsically Safe HEAT DETECTOR

POLON 4000 and POLON 6000 INTERACTIVE FIRE DETECTION AND ALARM SYSTEM

INSTALLATION AND MAINTENANCE MANUAL

IK-E280-001GB

III C Issue

  **KDB**



The TUN-38Ex heat detector covered by the present manual, complies with the requirements of the following European Union Directives:

CPD	89/106/EWG	on construction materials;
LVD	2006/96/WE	on electric equipment to be used in determined voltage range;
EMC	2004/108/WE	on electromagnetic compatibility;
ATEX	94/9/WE	on equipment and protective systems intended for use in potentially explosive atmospheres.

The TUN-38Ex Heat Detector has been approved with the EC-Certificate of Conformity No. 1438/CPD/0025 issued by the Fire Protection Science and Research Centre (CNBOP) Józefów, Poland, a EU notified authority No. 1438, confirming its compliance with the requirements of PN-EN 54-5:2003 standard.

The Central Mining Institute, Katowice, Poland, a EU notified authority No. 1453, has issued the following certificates concerning the TUN-38Ex Heat Detector:

- WE type Inspection Certificate No. KDB 04ATEX172X + Supplement No. 1
- Quality Assurance Acknowledgement No. GIG 04 ATEXQ 021
- WE Conformity Declaration No. 3/E280/2010

The Certificates may be downloaded from www.polon-alfa.pl web site.

 1438; 1453
Polon-Alfa Limited Partnership 155, Glinki Street, PL 85-861 Bydgoszcz, POLAND 05 1438/CPD/0025
EN 54-5 TUN-38Ex Heat Detector (conventional, universal, non-detachable) Application – fire safety
Technical data - IK-E280-001GB manual

Read the manual carefully before assembling and operation of the base and the base attachment. Any nonconformity with the instructions contained in the manual may be harmful or may cause violation of the law in force
 POLON-ALFA bears no responsibility for any damage resulting from usage inconsistent with the manual.

The product contains parts that can be dangerous for human health. The waste product shall be passed to the nearest waste electric and electronic equipment collection point.	
-------------------------------------------------------------------------------------------------------------------------------------------------------------------------------	---------------------------------------------------------------------------------------

NOTE: The manufacturer reserves the right to change specifications of products at any time without prior notice.

1 PURPOSE

The TUN-38Ex Heat Detector is designed for detection of fire hazard or fire appearance warning in closed rooms, where during the first phase of fire an occurrence of temperature rise may be observed, or where – due to various reasons – temperature may exceed the set fire danger level.

It is provided for working together in fire detecting lines with control panels manufactured by POLON-ALFA or by other producers that obtained POLON-ALFA's compatibility confirmation.

The detector's operational temperature is between - 25 °C and + 50 °C for A1 class and + 65 °C for B class.

The TUN-38Ex heat detectors are connected to fire detecting lines through intrinsically safe barrier or separator of the following parameters: $U_0 \leq 25 \text{ V}$, $I_0 \leq 99 \text{ mA}$. The detectors are installed in rooms and zones qualified as 1st and 2nd explosive hazard category resulting from potential explosion danger of explosive gases or inflammable liquid vapours that are ranked at IIA, IIB and IIC explosiveness subgroups and T1 up to T6 temperature classes.

Allowable ambient temperature range:

- 25 °C up to + 65 °C for T6 temperature class,

- 25 °C up to + 85 °C for T1...T5 temperature classes.

2 TECHNICAL SPECIFICATIONS

Operating voltage	20 V +20 % -15 %
Quiescent current	<100 μA
Alarm current	20 mA
Minimum operational temperature limit	-25 °C
Relative humidity	$\leq 95 \%$ at 40 °C
Detector class according to PN-EN 54-5 standard	A1R; A1S; BR; BS
Activation time	according to Table 1
Static activation temperature	54 °C up to 65 °C (A1 class) 69 °C up to 85 °C (B class)
Normal operating temperature	25 °C (A1 class) 40 °C (B class)
Mass	0,26 kg (<0,3 kg)
Dimensions (L x B x H) (fig. 4)	112 x 62,5 (83,5) x 55 mm
Assembly holes spacing	72 mm
Casing ingress protection	IP 54
Casing colour	Black
Intrinsic safety rating	Ex i _b IIC T1 - T5, for < 65 °C T6

3 INSINTRIC SAFETY PARAMETERS

Supply line marginal parameters:

Maximum input voltage	U_i	25 V
Maximum input current	I_i	99 mA
Maximum input power	P_i	0,613 W
Maximum inner capacity	C_i	16,5 nF
Maximum inner inductance	L_i	0*
Maximum outer capacity	C_o	110 nF **
Maximum outer inductance	L_o	2,5 mH**

Detector-alarm indicator connecting line parameters:

Maximum output voltage	U_o	25 V***
Maximum output current	I_o	99 mA***
Maximum output power	P_o	0,613 W***

* negligible parameters

** represents the sum of capacity and inductance resulting from the length of cables that may be connected to the detector

*** values that may occur in case of uncountable damages

Intrinsically safe barrier or separator parameters:

Maximum output voltage	U_o	25 V
Maximum output current	I_o	99 mA
Maximum output power	P_o	0,613 W
Minimum output resistance	R_i	300 Ω
Maximum outer capacity	C_o	110 nF
Maximum inner inductance	L_o	2,5 mH

Connecting cable example (YnTKSY):

Core diameter	mm	0,8	1,0
Single core resistance	Ω /km	37,5	24
Pair of cores capacity	nF/Km	120	120
Inductance	mH/km	0,7	0,7

Note:

The total line capacity and line inductance as well as total inner inductance of the detectors installed behind an intrinsically safe barrier of separator must not exceed the level of 110 nF and 2,5 mH. As a result in practice it is not possible to connect more than five TUN-38Ex detectors behind an intrinsically safe barrier of separator.

4 SAFETY CONDITIONS

4.1 Repairs and maintenance

Any maintenance works or periodic inspection shall be executed by skilled personnel employed by companies authorised and trained by POLON-ALFA.

Any repairs must be carried out by the manufacturer. POLON-ALFA bears no responsibility for the operation of any apparatus being repaired by unauthorised personnel.

4.2 Works at height

Any detector installation works carried out at height must be executed with particular care utilising tools and machinery in good working condition.

Special attention shall be given to stability of ladders, elevators, lifts, etc.

Any electric tools shall be used strictly obeying the safety rules stated in instruction manuals by manufacturers.

4.3 Anti-dusting eye protection

It is obligatory to use protective anti-dusting glasses and masks during detector installation works that produce high amount of dust, such as hole drilling in ceilings.

5 CONSTRUCTION DESCRIPTION

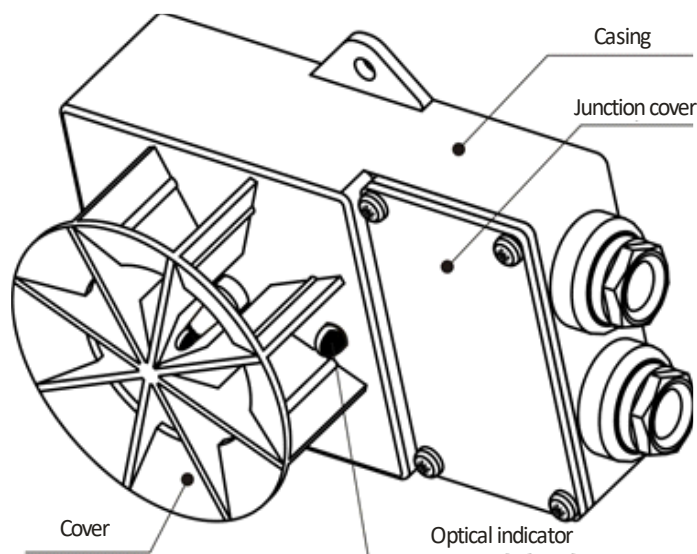

Fig. 1 TUN-38Ex detector overall view

The detector casing is made of black colour plastic. In order to remove electrostatic charge, low surface resistance material is utilised. The thermistor is protected with a specially shaped cover that ensures proper directional characteristics. Joints to connect detecting line cables and cramps to set activation class are situated under the cover.

Electronic circuit is inundated to protect from adverse operational environment; this protection assures detector's in proper work explosive atmosphere.

6 PRINCIPLES OF OPERATION

The TUN-38Ex heat detector reacts to a rise of temperature occurring during initial phase of fire. The detector operates as a fixed temperature detector after exceeding its set-off operation threshold, according to its given class. It operates also as a rate-of-rise heat detector - when the rapid rise of temperature exceeds the level determined for the detector, according to its given class, the electronic circuit transmits a warning signal to the master control panel. The signal may also result from the thermistor damage/malfunction.

The detector is provided with a signalling LED diode that shines in alarm mode. The indicator enables fast localisation of the activated detector and is helpful in periodic detector's inspections. In case the detector is installed in a hard to reach space, an additional optical alarm signal can be obtained by connecting the WZ-31 alarm in an accessible and visible place.

The detector activation times for particular classes are given in Table 1 (according to PN-EN 54-5).

Table 1

Air temperature increase rate in relation to normal operating temperature	A1 Class				B Class			
	Low activation time limit		Top activation time limit		Low activation time limit		Top activation time limit	
K/min	min	s	min	s	min	s	min	s
1	29	00	40	20	29	00	46	00
3	7	13	13	40	7	13	16	00
5	4	09	8	20	4	09	10	00
10	1	00	4	20	2	00	5	30
20		30	2	20	1	00	3	13
30		20	1	40		40	2	25

The heat detector operating parameters (for both classes) are shown in Table 2:

Table 2

Detector Class	Normal Operating Temperature °C	Maximum Operating Temperature °C	Minimum Static Activation Temperature °C	Maximum Static Activation Temperature °C
A1	25	50	54	65
B	40	65	69	85

The terms used in the tables have the following meaning:

Normal Operating Temperature

Maximum Operating Temperature

maximum temperature level, at which detector operates for a short period of time provided no fire hazard occurs.

Static Activation Temperature

temperature level at which detector transmits a warning signal at negligible low temperature increase rate.

A1R Class is divided into two sub-classes: AiR-L – nominal sensitivity and A1R-H – increased sensitivity at rapid temperature rise.

Typical activation temperature levels in the function of temperature increase starting from typical operation temperature at constant air flow equivalent to 0,8 m/s at 25°C are shown on Chart 1:

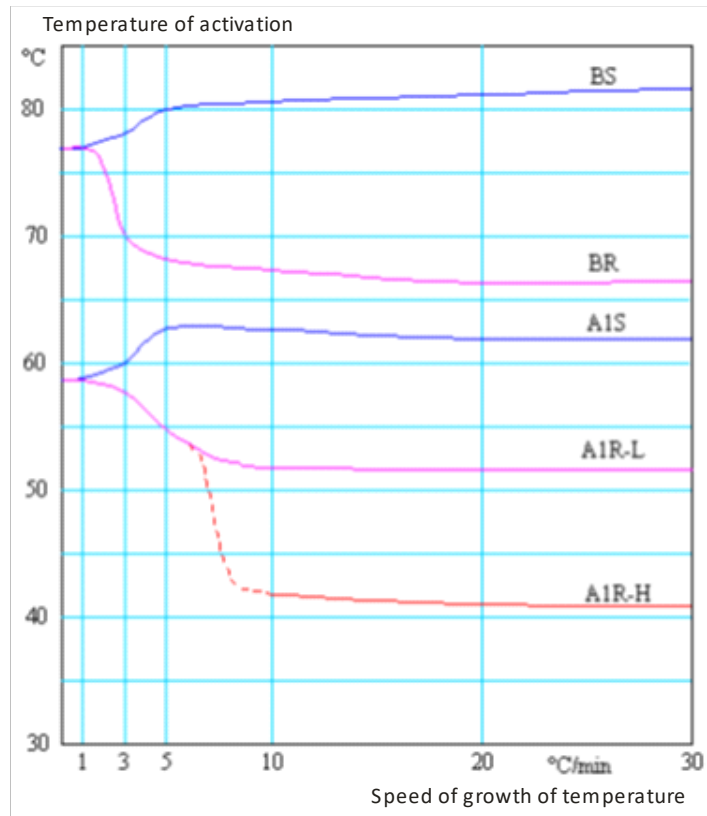

Chart 1

7 DETECTOR INSTALLATION

Determine the detector class with the cramps that are accessible after the cover removal. Cramp positions corresponding to various classes is shown on Figure 2.

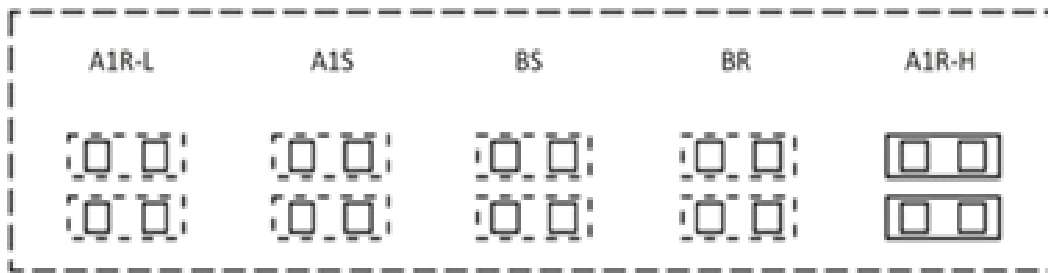

Fig. 2 Cramp positioning for various detector class (example of A1R-H).

Detectors shall be connected to detecting lines in accordance with Figure 3.

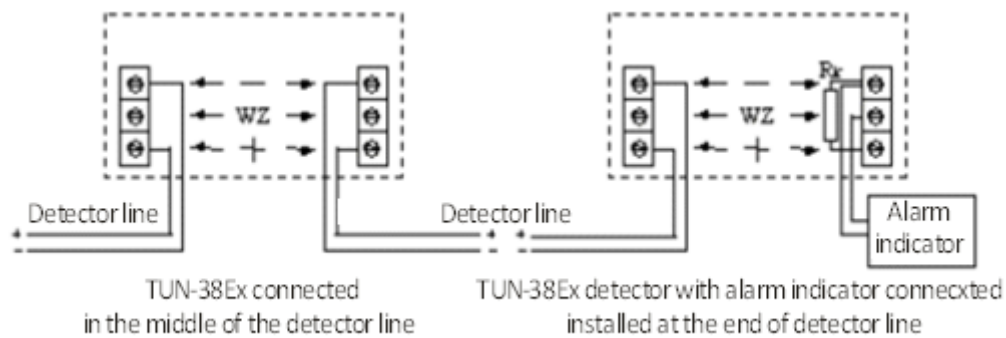

Fig. 3 Exemplary TUN-38Ex detector connection to detecting line.

It is obligatory to utilize intrinsically safe barrier or separator (named in the control panel Operational Manual) in intrinsically safe detecting lines. After installing all detectors, the control panel or supplying apparatus should be switched on. Every detector must be individually checked. It is not recommended to warm up more than one detector in one detecting line. In case more than three detectors in one detecting line are warmed up at the same time a false damage (short circuit) signal may be transmitted.

After the fire alarm is sounded in the control panel or supply-alarming device, warm-up process should be terminated and the alarm cancelled with the appropriate control panel button or short detector supply circuit interruption.

8 DETECTOR MAINTENANCE

It is recommended to carry out periodic detector operation checks that cover:

- overall examination and dust, dirt, cobweb, etc. removal
- periodic device functioning test.

The TUN-38Ex detector is required to pass periodic controls, carried out at least once in 6 months, to prove that the detector operates properly and works together with the fire control panel properly.

Any damaged detector must be passed for repair to the manufacturer.

During renovation or painting works detectors shall be protected from damage or dirt.

9 STORAGE AND TRANSPORTATION

9.1 Storage

The TUN-38Ex detectors must be kept in individual packages in closed rooms at the temperature of +5 °C up to +35 °C, relative humidity up to 80%. Surrounding environment shall be free of volatile compounds of sulphur and acid or alkaline exhausts.

The detectors shall be stored at a minimum distance of 1.5 m from heating elements.

9.2 Transportation

The TUN-38Ex detectors can be carried with any transport means provided the transport instructions given on their packing are observed and they are properly protected from any mechanical damage. It is forbidden to transport the goods at temperatures lower than -40 °C and higher than +70 °C (at relative humidity up to 80%) or at relative humidity higher than 95% at temperature of +40 °C.

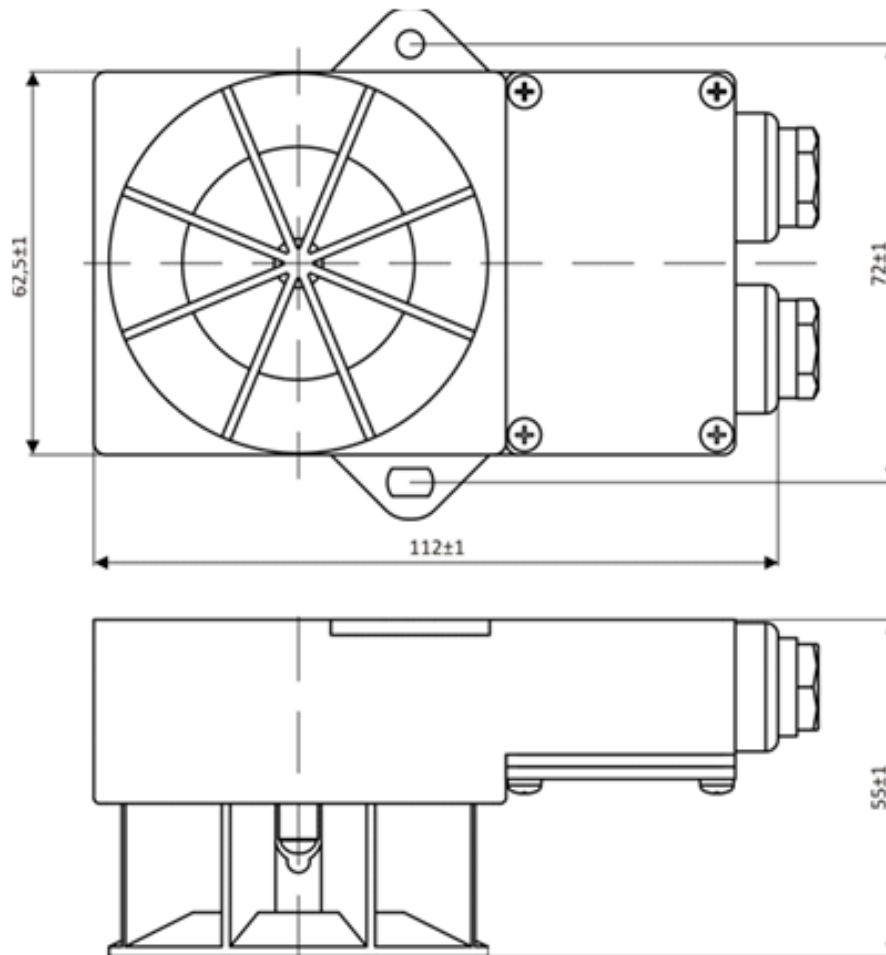

Fig. 4 TUN-38Ex detector basic dimensions



POLON-ALFA S.A.

POLAND 85-861 Bydgoszcz, ul. Glinki 155 | www.polon-alfa.pl
EXPORT DEP. phone no. +48 52 36 39 278, email: export@polon-alfa.pl
SERVICE DEP. phone no. +48 52 36 39 390, email: serwis@polon-alfa.pl