

POLON 4200 FIRE DETECTION AND ALARM ADDRESSABLE CONTROL PANEL

POLON 4000 and POLON 6000 INTERACTIVE FIRE DETECTION AND ALARM SYSTEM

OPERATION AND MAINTENANCE DOCUMENTATION

ID-E300-001GB

VF Edition



The POLON 4200 fire detection and alarm control panel covered by the present manual, complies with the requirements of the following European Union Directives:

CPD 89/106/EWG on construction materials;
EMC 2004/108/WE on electromagnetic compatibility
LVD 2006/95/WE on low-voltage electric equipment.

The POLON 4200 addressable control panel has been attested with the EC-Certificate of Conformity No. 1438/CPD/0128 issued by the Scientific and Research Centre for Fire Protection (CNBOP) Józefów, Poland, a EU notified authority No. 1438, confirming its compliance with the requirements of 54-2:2002+A1:2007 standard.

The device has been also approved with the Allowance Certificate No. 0121/2008 issued by CNBOP.

The certificates may be downloaded from www.polon-alfa.pl web site.

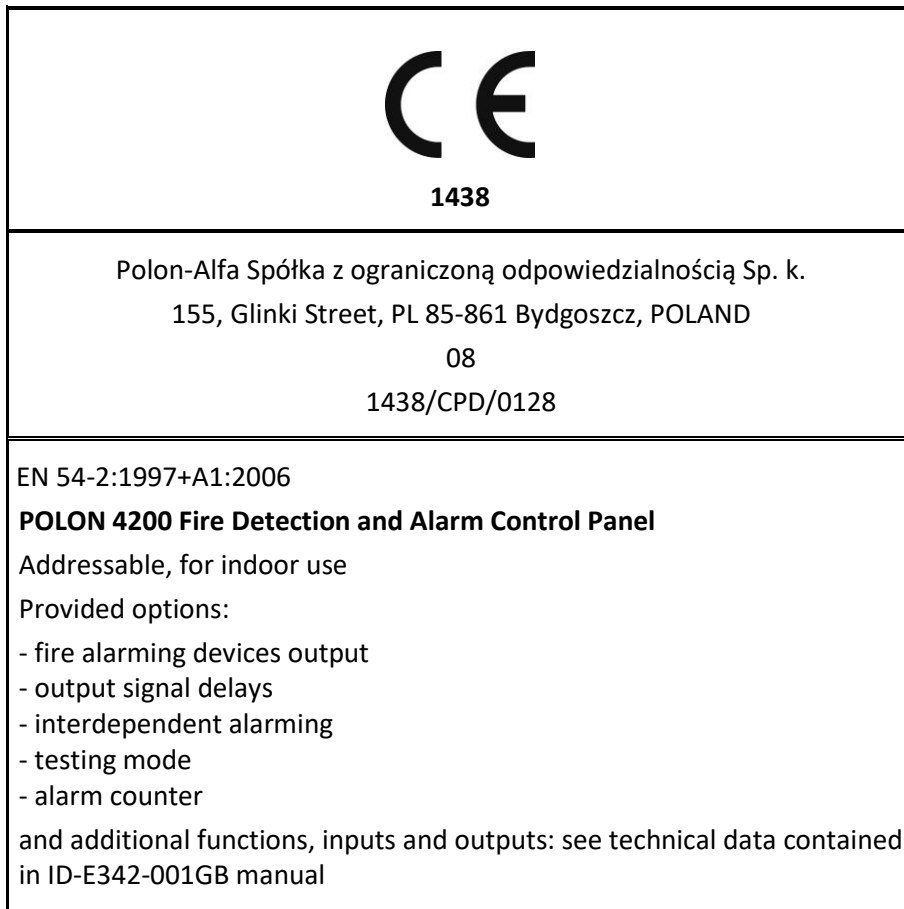

Read the manual carefully before the detector assembling and commissioning.

Any nonconformity with the instructions contained in the manual may be harmful or may cause violation of the law in force

POLON-ALFA bears no responsibility for any damage resulting from usage inconsistent with the manual.

A waste product, unsuitable for further use, shall be passed to a waste electric and electronic equipment collection point.



NOTE: The manufacturer reserves the right to change specifications of products at any time without prior notice.

CONTENTS

| | |
|--|-----------|
| 1 INTRODUCTION | 6 |
| 1.1. Documentation contents | 6 |
| 1.2 Control panel application | 6 |
| 1.3 Safety conditions | 6 |
| 1.3.1 Electric shock protection | 6 |
| 1.3.2 Installation and equipment safety | 6 |
| 1.3.3 Repairs and maintenance | 7 |
| 1.3.4 Fuse replacement | 7 |
| 1.4 Definitions | 7 |
| 2 DEVICE COMPLETENESS | 8 |
| 3 TECHNICAL SPECIFICATIONS | 9 |
| 4 DESIGN DESCRIPTIONS | 11 |
| 4.1 Overall control panel description | 11 |
| 4.2 Module arrangement | 11 |
| 4.3 Handling and signalling elements | 12 |
| 4.3.1 Optic LED indicators..... | 12 |
| 4.3.2 Control panel handling and signalling elements..... | 13 |
| 4.3.3 Numeric keypad and edition push buttons | 15 |
| 5 OPERATION DESCRIPTIONS | 16 |
| 5.1 General description | 16 |
| 5.2 TSO-4000 operator's console | 17 |
| 5.3. PSC-43 central controller module | 17 |
| 5.3.1 Module signalling and handling elements | 18 |
| 5.4 MSL-1M-42 line module | 19 |
| 5.5 PPW-42 programmable outputs/inputs module | 21 |
| 5.5.1 General description..... | 21 |
| 5.5.2 PK relay outputs and LS signal outputs..... | 21 |
| 5.5.3 Output to fire alarm devices (TYPE 1)..... | 23 |
| 5.5.3 Output to fire alarm transmission devices (TYPE 2) | 23 |
| 5.5.5 Output to protecting devices (TYPE 3)..... | 24 |
| 5.5.6 Fault/technical alarm signalling output (TYPE 4)..... | 24 |
| 5.5.7 Information output (TYPE 5) | 26 |
| 5.5.8 Reset output (TYPE 6) | 26 |
| 5.5.9 LK monitoring input | 26 |
| 5.5.10 PORT 1 and PORT 2 | 29 |
| 5.5.11 TSR-4000 terminal output..... | 30 |
| 5.5.12 Computer keyboard output | 30 |
| 5.6 DR-48 Printer | 31 |
| 5.7 Power Supply Module | 32 |
| 5.8 Control panel interoperation with battery cluster | 33 |
| 6 ADDRESSABLE DETECTION LINES | 34 |
| 6.1 Detection lines types | 34 |
| 6.2 Addressable elements numbering | 35 |
| 6.2.1 Automatic configuration | 35 |
| 6.2.2 Configuration with verification | 35 |
| 6.2.3 Manual number allocation..... | 35 |
| 6.3 Design guidelines | 36 |
| 7 ALARMING SYSTEM/STRUCTURE | 36 |
| 7.1 Detection zone | 36 |
| 7.2 Addressable elements declaration | 37 |

| | |
|--|-----------|
| 7.3 Assigning alarm parameters to zones..... | 37 |
| 7.4 EKS-4001 monitoring and controlling elements declaration | 38 |
| 7.5 EWS-4001 multi-output controlling elements declaration..... | 42 |
| 7.6 EWK-4001 multi-input monitoring elements declaration | 44 |
| 7.7 SAL-4001 acoustic signalling devices declaration | 45 |
| 7.8 UCS 4000 universal controlling panel declaration | 47 |
| 7.9 UCS 6000 universal control panels declaration | 49 |
| 7.10 TSR-4000 terminals declaration | 52 |
| 8 FUNCTIONALITY DESCRIPTIONS | 52 |
| 8.1 Alarming..... | 52 |
| 8.1.1 Alarm types | 52 |
| 8.1.2 One-stage alarm (variant 1) | 53 |
| 8.1.3 Two-stage alarm (variant 2)..... | 53 |
| 8.1.4 One-stage alarm with warning device single reset 40/60 s (variant 3) | 54 |
| 8.1.5 One-stage alarm with warning device single reset 60 s/8 min (variant 4) | 54 |
| 8.1.6 Two-stage alarm with warning device single reset 40/60 s (variant 5)..... | 54 |
| 8.1.7 Two-stage alarm with warning device single reset 60 s/8 min (variant 6) | 54 |
| 8.1.8 One-stage alarm with coincidence of two warning devices (variant 7)..... | 54 |
| 8.1.9 Two-stage alarm with coincidence of two warning devices (variant 8) | 55 |
| 8.1.10 One-stage interactive alarm (variant 9)..... | 55 |
| 8.1.11 Two-stage interactive alarm (variant 10)..... | 55 |
| 8.1.12 One-stage alarm with group-time coincidence (variant 11)..... | 55 |
| 8.1.13 Two-stage alarm with group-time coincidence (variant 12)..... | 56 |
| 8.1.14 Two-stage alarm with group coincidence in order to speed up 2 nd stage alarm (variant 13) ... | 56 |
| 8.1.15 Two-stage alarm with preliminary zone reset and group coincidence in order to speed up 2 nd stage alarm (variant 14)..... | 56 |
| 8.1.16 Two-stage alarm with two-detector coincidence in order to speed up 2 nd stage alarm (variant 15) | 56 |
| 8.1.17 Two-stage alarm with preliminary zone reset and two warning devices coincidence in order to speed up 2 nd stage alarm (variant 16) | 57 |
| 8.1.18 One-stage alarm with temporal zone disconnection (variant 17) | 57 |
| 8.1.19 ROP manual call point alarming..... | 57 |
| 8.1.20 Alarming in 'DELAYS OFF' mode | 57 |
| 8.1.21 Alarming in 'PERSONNEL ABSENT' mode..... | 57 |
| 8.2 Fault signalling..... | 58 |
| 8.2.1 Faults type..... | 58 |
| 8.3 Testing..... | 59 |
| 8.3.1 TSO-4200 table signalling elements testing..... | 60 |
| 8.3.2 Testing of line fire elements in a zone | 60 |
| 8.3.3 EKS-4001 monitoring and controlling elements testing | 60 |
| 8.3.4 EWS-4001 controlling elements testing..... | 60 |
| 8.3.5 EWK-4001 monitoring elements testing | 60 |
| 8.3.6 SAL-4001 acoustic signalling devices testing | 60 |
| 8.3.7 Line elements location inspection | 60 |
| 8.4 System elements disablement/re-enablement..... | 61 |
| 8.4.1 Fire warning devices and zones disablement/re-enablement..... | 61 |
| 8.4.2 PK relays disablement/re-enablement | 61 |
| 8.4.3 LS signalling line disablement/re-enablement..... | 61 |
| 8.4.4 LK monitoring lines disablement/re-enablement..... | 61 |
| 8.4.5 EKS-4001 monitoring and controlling elements disablement/re-enablement..... | 61 |
| 8.4.6 EWS-4001 controlling elements disablement/re-enablement | 61 |
| 8.4.7 EWK-4001 monitoring elements disablement/re-enablement | 62 |
| 8.4.8 SAL-4001 acoustic signalling devices disablement/re-enablement..... | 62 |
| 8.5 Event memory and alarm memory..... | 62 |
| 8.5.1 Event memory..... | 62 |

| | |
|---|-----------|
| 8.5.2 Alarm memory | 62 |
| 9 STANDARD CONFIGURATION | 63 |
| 9.1 User configuration programming | 63 |
| 9.2 Standard configuration/access codes loading | 63 |
| 10 ACCESS CODES | 64 |
| 11 INSTALLATION..... | 64 |
| 11.1 Control panels installation location..... | 64 |
| 11.2 Power supply connection | 65 |
| 11.3 Line elements installation..... | 65 |
| 11.4 Control panel inputs and outputs..... | 66 |
| 12 OPERATION AND MAINTENANCE..... | 67 |
| 12.1 Proper operation rules | 67 |
| 12.2 Periodic inspections and maintenance rules..... | 68 |
| 13 PACKING, TRANSPORTATION, STORAGE | 68 |
| 13.1 Packing | 68 |
| 13.2 Transport rules..... | 68 |
| 13.3 Storage rules..... | 68 |
| 14 DESIGNER’S TABLES..... | 69 |
| APPENDIX A – POLON 4000 SYSTEM LINE ELEMENTS | 77 |

1 INTRODUCTION

1.1. Documentation contents

The purpose of this Operation and Maintenance Documentation (OMD) is to present the application, design and operation of the POLON 4200 fire detection and alarm control panel which constitute a part of the POLON 4000 system. The OMD contains information necessary for the panel proper installation, servicing and operation as well as may be helpful in fire detection and alarm system designing.

The Programming Manual (PM) constitutes a supplement to the OMD and it describes the control panel programming process.

Line elements that interoperate with the panel and can be installed in the POLON 4200 control panel detection lines are listed in Appendix A. Detailed information about the elements interoperation with the POLON 4200 control panel are contained in a particular device installation and maintenance manual.

The OMD is supplied to the panel user together with the device; the PM programming manual is delivered only to trained and authorized designing and installing companies.

1.2 Control panel application

The POLON 4200 fire detection and alarm control panel is designed to:

1. signal a fire occurrence detected by an interoperating fire warning devices (automatic and manual),
2. indicate a fire endangered place,
3. activate fire protection equipment,
4. transmit a fire signal to proper services, e.g. Fire Brigades.

The control panel is intended for continuous operation in premises of low dust level at ambient temperature from - 5 °C to + 40 °C and air relative humidity up to 80 % at +40 °C.

1.3 Safety conditions

1.3.1 Electric shock protection

The POLON 4000 system fire control panels are ranked as the 1st protection class devices and can be used only in the case of application of additional protection against electric shocks, such as zeroing or protective grounding.

230 V/50 Hz mains supply circuits insulation is reinforced and resists 2800 V voltage test; low-voltage circuits (below 42 V) insulation is able to resist test voltage of 700 V DC. After mains conductor connection, the mains connectors should be protected with a factory shield.

1.3.2 Installation and equipment safety

Wire installation should be made using cables of the required fire resistance and should be properly protected in passages through fire zone boundaries. In order to avoid undesirable interaction, a required distance between the low-voltage installation and a power installation and a lightning

protection system should be maintained. From the system electromagnetic interference immunity, it is recommended to utilise protective grounding. Reserve power supply batteries should be connected to the panel at the final stage of the installation.

The panel components are heat sensitive. The maximum ambient temperature should not exceed + 40 °C. It is forbidden to block ventilation openings placed on the panel side. The space left around the device should be big enough to secure free air flow. Air humidity in the premises where the panel operates should not exceed 95 %.

1.3.3 Repairs and maintenance

Maintenance works and periodic inspections should be executed by skilled personnel employed by companies authorised or trained by Polon-Alfa. Any repairs must be carried out by the manufacturer. Polon-Alfa bears no responsibility for the operation of any apparatus being serviced or repaired by unauthorised personnel.

1.3.4 Fuse replacement

In the event of fuse replacement, an equivalent fuse should be used: of the appropriate type and nominal value. The appropriate types and nominal values are contained in table 2.2 and in p. 12 of this manual.

1.4 Definitions

Addressable detection line

A detection line that enables an addressable element connection.

Side detection line

A detection line for two-state non-addressable fire warning devices, created using the ADC-4001 adapter.

Addressable element

A device operating in a detection line which possesses a unique and unchangeable identity feature in the form of serial number and an element number which is assigned during system configuration. An addressable element enables two-direction digital data exchange with the control panel (transmission and receiving).

Line element

An element installed in addressable detection lines (addressable element) and side lines (non-addressable element).

Factory (serial) number (factory address)

A unique 12-digit number which is assigned to every addressable element during manufacturing process. The factory number contains the addressable element type being identified by the control panel.

Line number

A consecutive number from 1 ÷ 2 range, which is assigned to an open or loop-shaped detection line.

Element number

A consecutive number from 1 ÷ 64 range, which is assigned to an addressable element during the detection line configuration. During normal operation, control panel intercommunicates using the element number (short number).

Address space

A set of digit pairs composed of a line number and element number that determines all possible program element arrangements in a circuit.

Zone

A separated part of a supervised facility that specific line elements are assigned to.

Non-maskable fault

A fault related to the EKS-4001 element or the LK monitoring lines.

Standard configuration

A set of data that determines the control panel equipment furnishing and its operation arrangement (e.g. addressable element declaration, element assignment to particular zones, alarm variants), settled and loaded to the memory by the manufacturer.

User message (text)

A message on the text display (a wordy text not longer than 64 characters), assigned to line elements or conventional lines during programming process, utilized by the user for their installation location identification.

Quiescent (supervision) mode

An operation mode, in which the control panel is power supplied from an electric energy source that meets the settled requirements, during which no other operation mode is indicated.

Alarm (fire) mode

An operation mode the control panel triggers after receipt and verification of a fire occurrence signal from fire warning devices.

Preliminary alarm mode (first alarm mode)

An operation mode the control panel triggers after receipt of the first alarm signal from fire warning devices.

Disablement mode

An operation mode, in which it is deliberately blocked the control panel ability to receive signals from any fire warning devices and to evoke alarms, or the control panel output and/or transmission path to any fire detection and alarm system component that is a part of alarm circuit.

Testing mode

An operation mode in which the control panel indicates functioning checking.

Fault mode

An operation mode in which the control panel indicates a fault of anything in alarm installation or its own circuits.

Technical alarm mode

An operation mode in which the control panel indicates actuation of any supervised external devices or a service mode of fire detectors.

POLON 4000 system digital monitoring (PMC-4000)

A digital monitoring protocol applicable in POLON 4000 control panels.

2 DEVICE COMPLETENESS

Table 2.1 lists the set of items which compose the POLON 4200 control panel furnishings.

Table 2.2 contains a list of the fuses used in the control panel.

Table 2.3 specifies auxiliary equipment that can be installed in the POLON 4200 control panels. This equipment should be ordered separately.

Table 2.1

| Item | Description | Drawing (catalogue) No. | Quantity pcs |
|------|---|----------------------------|-----------------|
| 1 | Complete casing | A/E300-50.00.00-1 | 1 |
| 2 | MZ-4212 power supply module | B/E299-30.00.00-1 | 1 |
| 3 | PSC-43 central controller module | B/E300-80.00.00-1 | 1 |
| 4 | DR-48 printer | C/E270-40.00.00-1 | 1 |
| 5 | MSL-1M-42 line module | B/E300-70.00.00-1 | 1 |
| 6 | PPW-42 programmable outputs module | B/E300-10.00.00-1 | 1 |
| 7 | PS-49 signalling devices board | C/E270-200.00.00-1 | 1 |
| 8 | Hanger | B/E300-70.00.00-1 | 1 |
| 9 | Operation and Maintenance Documentation (OMD) | ID-E300-001E | 1 |
| 10 | Warranty certificate (when required) | | 1 |
| 11 | Control panel package | | 1 |

Table 2.2

| Item | Part description | Quantity |
|------|----------------------|----------|
| 1 | Melt fuse F3,15L250V | 1 pc |
| 2 | Melt fuse F1L250V | 3 pcs |
| 3 | Melt fuse F500L250V | 1 pc |
| 4 | Melt fuse F630L250V | 1 pc |

Table 2.3

| Item | Description | Drawing (catalogue) No. |
|------|----------------------------|-------------------------|
| 1 | PAR-4800 battery container | A/E270-140.00.00-1 |
| 2 | Hanger | B/E300-70.00.00-1 |
| 3 | Computer keyboard | |

3 TECHNICAL SPECIFICATIONS

| | |
|---|----------------------------------|
| Control panel supply voltage, mains 50 Hz | 230 V +10 % -15 % |
| Maximum mains current consumption | 0.8 A |
| Internal control panel operating voltage (direct current) | 24 V +25 % - 15 % |
| Reserve power supply source: | |
| – lead battery panel (sealed) 24 V of capacity | 17 ÷ 38 Ah |
| Maximum battery panel internal resistance, including connecting wires resistance | 1 Ω |
| Reserve power supply switching over | automatic |
| Battery charging switching over | automatic |
| Max. battery current consumption in quiescent mode | 0.4 A |
| Max. battery current consumption in alarm mode (without external devices) | 0.5 A |
| Max. available external devices current consumption in quiescent mode | 0.1 A |
| Max. available external devices current consumption in alarm mode (including LS1, LS2 signalling lines) | 0.6 A |
| Number of addressable detection lines | 4 |
| Maximum detection line voltage | 23.4 ÷ 24.6 V |
| Admissible detection line quiescent current (depending on configuration): | |
| – at max. wires resistance 2 x 100 Ω | 20 mA |
| – at max. wires resistance 2 x 75 Ω | 22 mA |
| – at max. wires resistance 2 x 45 Ω | 50 mA |
| Maximum admissible resistance of detection line wires: | |
| – addressable line, depending on configuration | 2 x 100 Ω, 2 x 75 Ω, or 2 x 45 Ω |
| – ADC-4001M side line | 2 x 25 Ω |
| – between two consecutive elements equipped with short isolators | 2 x 50 Ω |
| Maximum admissible capacity of addressable detection line wires | 300 nF |

| | |
|--|---------------------------|
| Minimum insulation resistance between wires in installation | 100 kΩ |
| Addressable detection line operation circuits: | |
| – loop-shaped, with a possibility to eliminate one break or short circuit in detection line wires (A type detection line), | |
| – radial without loop (B type detection line) | |
| Number of addressable elements in one line, depending on total quiescent current, but not higher than: | |
| – for A type detection line | 64 |
| – for B type detection line | 32 |
| Maximum number of EKS-4001 monitoring and controlling elements: | |
| – connected to the control panel, in total | 50 |
| Maximum number of EWS-4001 multi-output controlling elements: | |
| – connected to the control panel, in total | 50 |
| – connected to one detection line | 20 |
| Maximum number of EWK-4001 multi-input monitoring elements: | |
| – connected to the control panel, in total | 50 |
| – connected to one detection line | 20 |
| Maximum number of SAL-4001 acoustic signalling devices connected to the control panel | |
| | 50 |
| Maximum number of UCS 4000 universal controlling panels connected to the control panel | |
| | 50 |
| Maximum number of UCS 6000 universal controlling panels connected to the control panel | |
| | 50 |
| Number of zones that line elements are assigned to | 256 |
| Number of interdependent detector groups in zone | 2 (A and B) |
| Fire alarms types: | |
| – 1 st stage alarm | 1 ST ST. ALARM |
| – 2 nd stage alarm | 2 ND ST. ALARM |
| Number of alarming variants that can be applied in zones | 17 |
| Time programming ranges: | |
| – T1 time –1 ST ST. ALARM acknowledgment awaiting | 0 ÷ 10 min |
| – T2 time – situation recognition after 1 ST ST. ALARM acknowledgement | 0 ÷ 10 min |
| – T3 time –alarm outputs activation delay | 0 ÷ 10 min |
| Programmed outputs: | |
| – non-potential switchable contacts of 1A / 30 V relays | 8 (PK1 ÷ PK8) |
| – signalling line of 0.5 A/ 24 V loading capacity | 1 (LS1) |
| – signalling line of 100 mA/ 24 V loading capacity | 1 (LS2) |
| Programmed inputs – monitoring lines: | |
| – number of monitoring lines | 2 (LK1, LK2) |
| – monitoring line resistance | see table 5.9 |
| Maximum number of zones assigned to outputs (total number of assignments to outputs of PK and LS type, and EKS-4001, EWS-4001, UCS 4000, UCS 6000 line elements) | |
| | 64,000 |
| Maximum number of recorded events (EVENT MEMORY) | 2,000 |
| Maximum number of recorded alarms (ALARM MEMORY) | 9,999 |

| | |
|---|--------------------|
| Liquid crystals display (graphical) resolution | 320 x 240 pixels |
| Control panel mass (without batteries) | ca. 11 kg |
| Control panel dimensions | 483 x 393 x 190 mm |
| PAR-4800 battery container dimensions | 212 x 492 x 195 mm |
| Ingress protection of control panel cabinet | IP 30 |
| Operating temperature range | -5 °C ÷ +40 °C |
| External devices interoperation: | |
| – computer keyboard, | |
| – personal computer, | |
| – POLON 4000 system (PMC-4000) digital monitoring system, | |
| – interoperation of the control panel with the TSR-4000 terminal: | |
| – maximum number of terminals connected to one control panel | 16 |

4 DESIGN DESCRIPTIONS

4.1 Overall control panel description

The control panel is made in the form of a metal cabinet intended for wall mounting with the help of a special metal frame. The cabinet door, which is also the control panel front side, is equipped with a cylinder lock.

All signalling and handling elements are located on the control panel door. Electronic circuit modules and a mains power supply unit are placed inside the cabinet.

Round holes are provided (at the control panel back side top) for installation wires introduction. Below, there is a round rubber pass to introduce mains power supply and grounding wires. It is possible to place two 12 V 17 – 22 Ah capacity batteries inside the cabinet in its left part.

The control panel can be optionally equipped with the PAR-4800 battery container of the dimensions that enable inserting two 12 V batteries of capacity up to 38 Ah.

It is possible to connect a computer keyboard (PS/2 standard) to the control panel.

4.2 Module arrangement

The POLON 4200 control panel module arrangement is shown in Fig. 4.1.

They are placed on the control panel door and walls; fastened with screws.

The PSC-43 central controller module, together with an LCD display, is mounted on the door. The DR-48 thermal printer is located in the right hand lower corner of the cabinet, and a signalling device board with the main fire indicator - above it.

The following modules are located on the back wall:

- PPW-42 programmable outputs module, on the left upper side,
- MSL-1M-42 detection lines module, supporting 1 ÷ 4 detection lines, on the right,
- MZ-4212 power supply module, on the right side below.

Note:

Any module installation or removal can be carried out only with disconnected power supply sources.

4.3 Handling and signalling elements

4.3.1 Optic LED indicators

The signalling and handling elements are placed on the control panel door, which is called the TSO-4200 signalling and operating board or, in other words, the operator's console. Fig. 4.2 presents the signalling and handling elements arrangement.

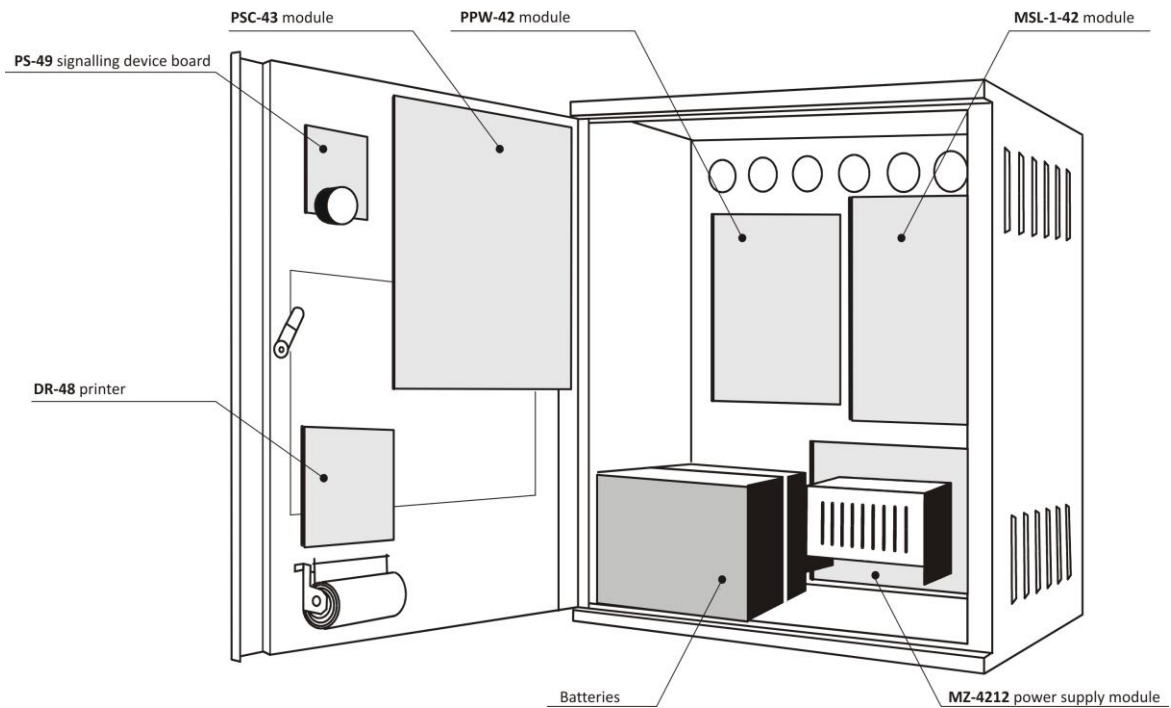

Fig. 4.1 POLON 4200 control panel main elements arrangement

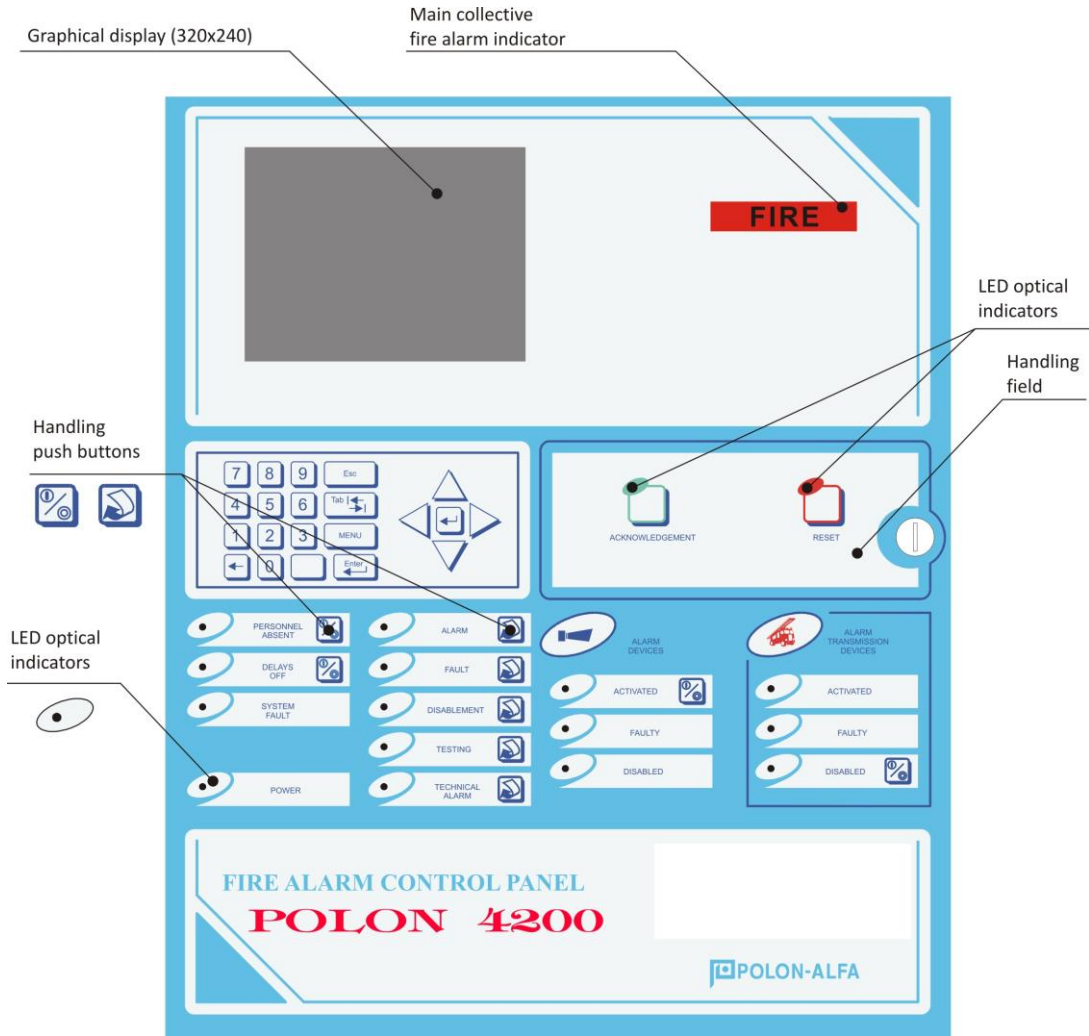

Fig. 4.2 Signalling and handling elements located on the control panel front plate

4.3.2 Control panel handling and signalling elements

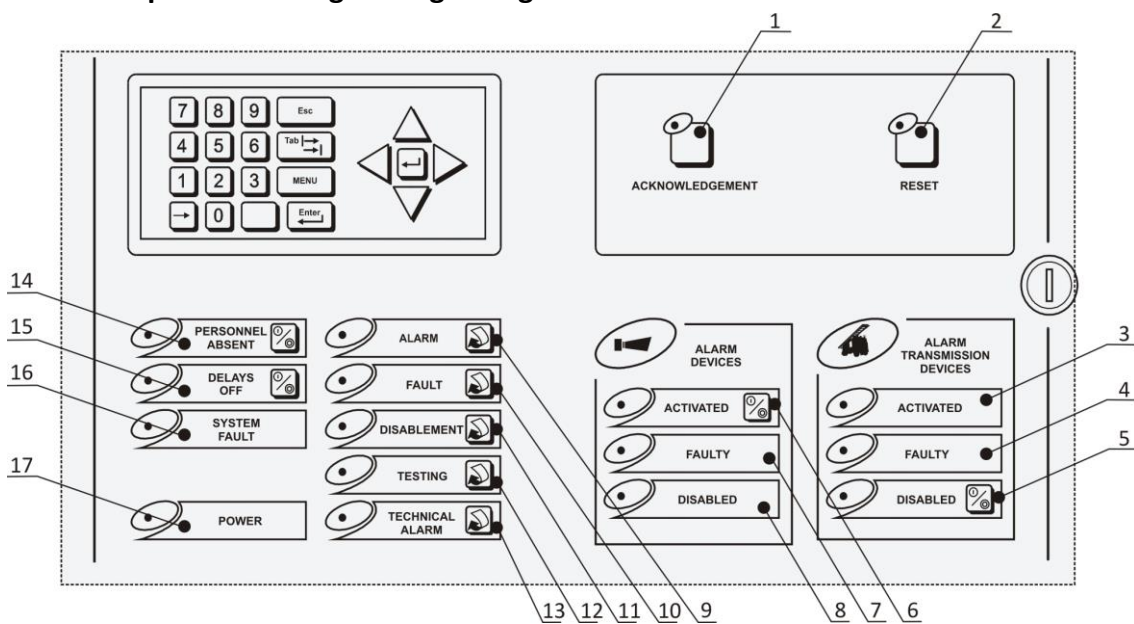

Fig. 4.3 Control panel handling and signalling elements

1 – ACKNOWLEDGEMENT

- a) **indicator** – active acknowledgement function,
- b) **push button** – to silence the control panel buzzer in the fire alarm, technical alarm or fault mode; in the two-stage alarm it actuates the T2 time.

2 – RESET

- a) **indicator** – active reset function,
- b) **push button** – fire alarm reset.

3 – ACTIVATED (ALARM TRANSMISSION DEVICES)

- a) **indicator** – at least one alarm transmission output is activated.

4 – FAULTY (ALARM TRANSMISSION DEVICES)

- a) **indicator** – alarm transmission device outputs faults:
 - steady light – some or all alarm transmission device outputs are faulty.

5 – DISABLED (ALARM TRANSMISSION DEVICES)

- a) **indicator** – alarm transmission device outputs disablement:
 - steady light – all alarm transmission device outputs are disabled,
 - pulsing light – some alarm transmission device outputs are disabled.
- b) **push button** – all alarm transmission device outputs switch on/off (with an exception for the outputs disabled permanently).

6 – ACTIVATED (ALARM DEVICES)

- a) **indicator** – at least one alarm output is activated.
- b) **push button** – switching on/off all alarm device outputs that meet the actuation criterion (with an exception for the outputs disabled permanently).

7 – FAULTY (ALARM DEVICES)

- a) **indicator** – some or all alarm device outputs are faulty.

8 – DISABLED (ALARM DEVICES)

- a) **indicator** – alarm device outputs disablement:
 - steady light – all alarm device outputs are disabled;
 - pulsing light – some alarm device outputs are disabled.

9 – ALARM

- a) **indicator** – collective of preliminary or fire alarm:
 - steady light – acknowledged preliminary or fire alarm,
 - pulsing light – non-acknowledged preliminary or fire alarm.
- b) **push button** – quick access to alarm messages;

10 – FAULT

- a) **indicator** – collective of a fault:
 - steady light – acknowledged fault,
 - pulsing light – non-acknowledged fault.
- b) **push button** – quick access to fault messages.

11 – DISABLEMENT

- a) **indicator** – collective of a disablement:
 - steady light – a disablement switched on.
- b) **push button** – quick access to disablement messages.

12 – TESTING

- a) **indicator** – collective of testing:
 - steady light– testing switched on.
- b) **push button** – quick access to testing messages.

13 – TECHNICAL ALARM

- a) **indicator** – collective of a technical alarm:
 - steady light – acknowledged technical alarm,
 - pulsing light – non-acknowledged technical alarm.
- b) **push button** – quick access to technical alarm messages.

14 – PERSONNEL ABSENT

- a) **indicator** –Personnel Absent mode.
- b) **push button** – Personnel Absent mode switch on/off.

15 – DELAYS OFF

- a) **indicator** – delays switch off.
- b) **push button** – all delay times (T1, T2, T3, Top) switch on/off.

16 – SYSTEM FAULT

- a) **indicator** – system (processor based circuits) fault.

17 – POWER SUPPLY

- a) **indicator** – control panel power supply:
 - steady light – control panel powered from the mains, no faults,
 - pulsing light – any power supply fault.

4.3.3 Numeric keypad and edition push buttons

Fig. 4.4 Numeric keypad and edition push buttons

0 ÷ 9 – numeric keypad.

MENU – control panel main menu display.

Esc – current operation aborting.

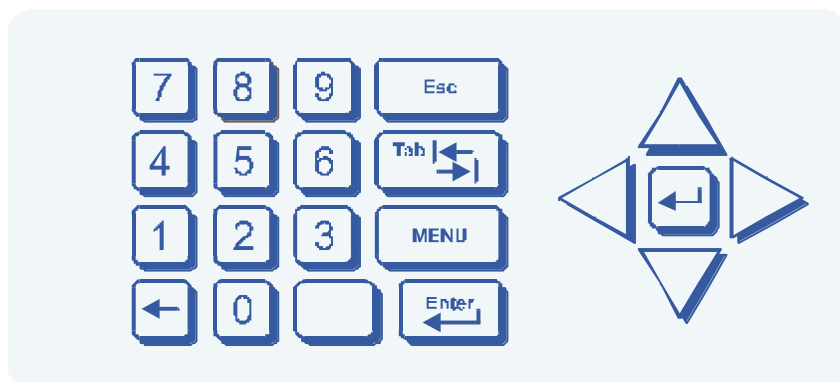
↵ Enter – approval of a currently selected menu option and moving the cursor to the beginning of the next line (during message edition)).

↔ Tab – movement from one menu window to another.

← Back Space – deleting the character to the left of the cursor and moving the text backwards one character space.

Space, unmarked key – inserting one character space in the cursor's position.

←↑→↓ – cursors.

Note:

Alternatively to the keypad located on the control panel door, a PS/2 computer keyboard can be used if it is connected through the socket placed on the PPW-42 module.

5 OPERATION DESCRIPTIONS

5.1 General description

The POLON 4200 control panel is a multi-microprocessor module-construction device. The control panel block diagram is presented in Fig. 5.1.

Line elements installed in an addressable detection line, after receiving an appropriate signal from the control panel (element's address), send relevant signals back with information about their type and status. Information exchange between the line elements and the control panel is executed through the MSL-1M-42 module. After an analysis of the received signals, the module passes proper information through the control panel bus to the PSC-43 central controller module, which is the main module of the control panel. Then the information is processed and adequate signals for remaining circuits are produced.

The PSC-43 module, fulfilling the programmed operation procedures, controls – through the bus – the relays or signalling lines located on the MLS-41 module.

The liquid crystal display, signalling and handling elements of the TSO-4200 panel, are controlled with the use of the μ PC microprocessor. The TSO-4200 panel main purpose is to provide communication between the attending personnel and the control panel.

The PPW-42 programmable outputs module enables external devices control using 8 relay outputs, 2 controlling lines and 2 monitoring lines. Auxiliary connections are provided in the module: a socket to connect a computer keyboard, a RS-232 (PORT1) serial connector, and a USB (PORT2) port to connect a computer or digital monitoring, as well as the RS-485 output to connect the TSR-4000 parallel indication terminals. Additionally, the module produces the following power supply voltage:

1. insulated voltage power supply: + 27 V for detection lines
2. insulated power supply voltage: + 5 V for serial outputs,
3. power supply voltage: + 5 V for the LCD display and the DR-48 printer.

The mains supply device is designed to provide the control panel operating voltage supply, in the case of the mains power supply outage – this function is fulfilled by a reserve battery panel.

The MZ-4212 power supply module produces operating voltage of +24 V for the control panel and +24 V – for the user.

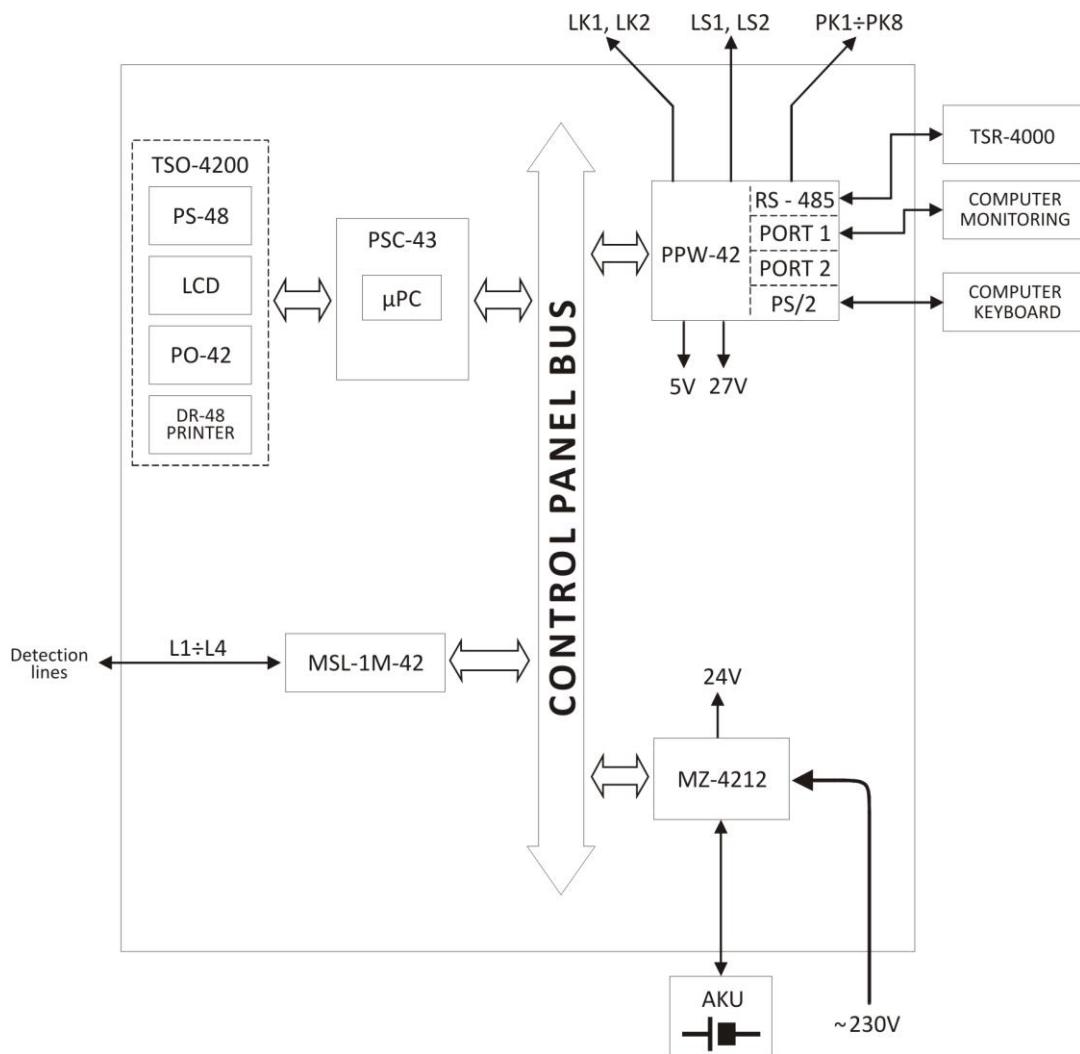

Fig. 5.1 POLON 4200 block diagram

5.2 TSO-4000 operator's console

The board TSO-4200 consists of the following main parts:

- liquid crystal display (LCD),
- PS-49 signalling devices board,
- PO-42 operation panel (keypad + signalling diodes),
- DR-48 printer.

The LCD is connected (mechanically and electrically) with the PSC-43 central controller board located on the control panel door.

5.3. PSC-43 central controller module

The PSC-43 central controller module is equipped with the μ PC (logically identified as μ P1) microprocessor circuit that ensures the control panel unfailing operation. The module is furnished with ROM program memory (located in a separated MP-43 module), RAM operational memory, and SETUP configuration memory (a database that determines the equipment environment and system operation arrangement).

The circuits that execute the central panel communication bus for information exchange and other modules (MSL-1M-42, PPW-42 and MZ-4212) controlling, are also located in the module.

The PSC-43 module is equipped with its own 5 V DC and 3.3 V DC converters to supply its own and external electronic circuits.

5.3.1 Module signalling and handling elements

On the PSC-43 module left inner edge there are two illuminating diodes that indicate the module operation service status. A mini-switch, marked as Reset μ PC, located in the board back, is used to perform the μ PC microprocessor's restart (by a short button pressing). On the module left side, the SW1 switch is placed – its keys functions are described in Table 5.1.

In order to perform the K1 key or K3 key operations described in Table 5.1, it is necessary to settle the appropriate SW1 switch key in ON position, push the Reset μ PC unstable switch and, after ca. 30 seconds, to settle the SW1 switch key again in OFF position.

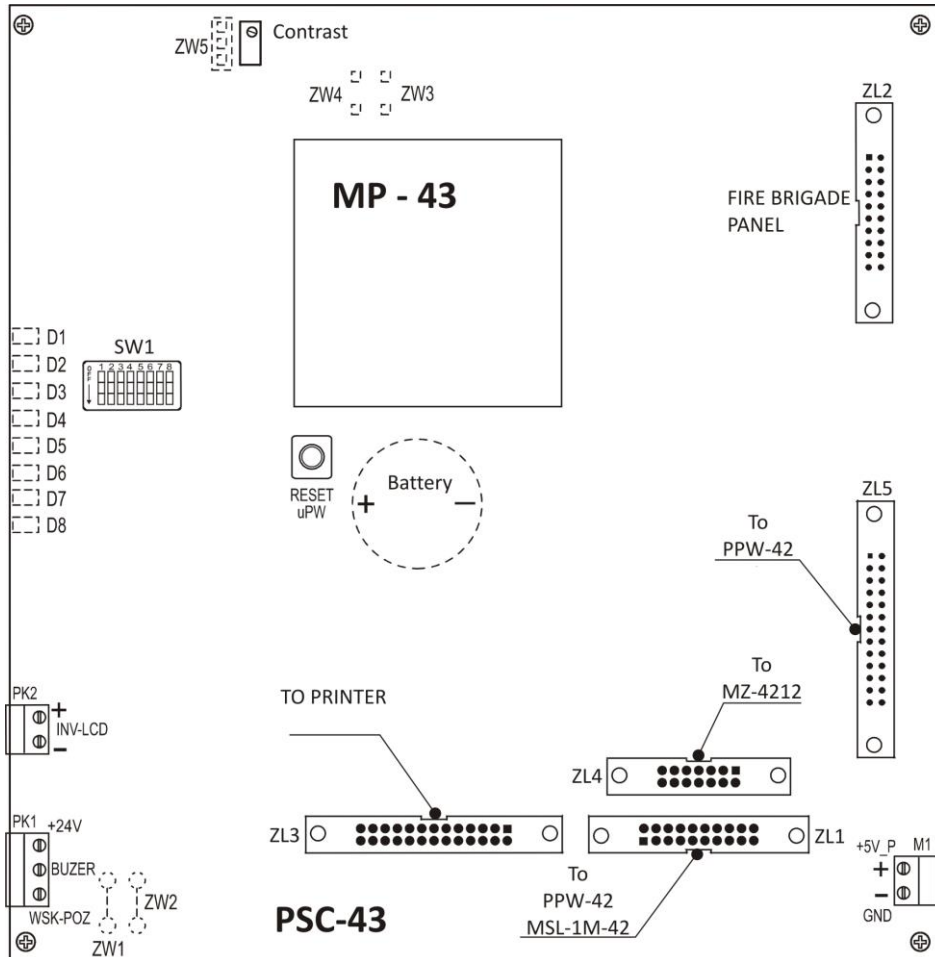

Fig. 5.2 PSC-43 central controller module

Table 5.1.

| SW1 Key | Position | Function |
|---------|----------|---|
| K1 | ON | After the μ PC microprocessor restart, standard system configuration loading |
| K2 | - | Unused |
| K3 | ON | After the μ PC microprocessor restart, loading standard access codes of 2 nd , 3 rd and 4 th level |
| K4 | ON | PSC-43 module servicing diodes switching on |
| K5 | - | Unused |
| K6 | ON | Authorisation for SYSTEM FAULT reset – the reset is executed after the μ PC microprocessor reset |
| K7 | - | Unused |
| K8 | - | Unused |

Notes:

In case the SW1 switch key 1 is settled in ON position and the PSC-43 module is restarted, the previous system configuration is deleted and the standard one is loaded in its place.

Leaving the keys 1 and 3 in ON position can result in a loss of the entered data and is indicated as a system fault.

5.4 MSL-1M-42 line module

The POLON 4200 control panel is permanently equipped with one MSL-1M-42 line module (logically called MSL-1) that enables connection of 4 loop-shaped detection lines marked as L1 ÷ L4.

The module overall view is shown in Fig. 5.3.

The MSL-1M-42 line module is provided for controlling and supporting the detection lines in which the POLON 4000 system addressable line elements are installed. Any addressable detection line can operate as a loop-shaped A type circuit or radial B type one (open line).

It is possible to connect to one detection line:

- up to 64 addressable elements in the loop-shaped layout;
- up to 32 addressable elements in the radial layout.

Operation in the loop-shaped layout enables elimination of one line fault – a line break, and isolation of a line short circuit between neighbouring addressable elements (all addressable elements are equipped with short circuit isolators).

The line module, with all connected addressable elements, becomes 'visible' to the control panel after its declaration. The MSL-1M-42 line module is declared by default by loop-shaped lines. The detection lines (loop or radial) type can be changed in the MSL-1M-42 module configuration MENU.

Maximum quiescent current of each detection line is linked with the detection line wires entire resistance and the programming line jumpers' position.

The S1 jumper and S9, S10, S11, S12 jumpers that programme the MSL-1M module should always be in the position shown in Fig. 5.3.

The service diodes, placed on the left edge of the module, enable displaying of general service states of the main processor and line processors. The line service diodes, located at the back of the module, enable displaying of the detection lines service status.

The MSL-1M-42 line module contains a microprocessor-based controller circuit with EPROM and RAM memories, a 5 V power supply unit as well as circuits for co-operation with the PSC-43 central controller module through the control panel bus. The detection lines are supplied from the +27 V insulated voltage source (which is placed on the PPW-42 module). Such the solution ensures high immunity to interferences and electric shocks. The line module also contains monitoring circuits to supervise 27 V DC voltage and earth fault, restart circuit with a switch and circuit for addressable detection line status signalling, based on illuminating diodes.

| Line No | Jumper | Jumper position | Max. current [mA] | Max. resistance [Ω] |
|---------|--------|-----------------|-------------------|------------------------------|
| L1 | S21 | 1 – 2 | 20 | 1 x 100 |
| | | 1 – 2 | 22 | 2 x 75 |
| | | 2 – 3 | 50 | 2 x 45 |
| L2 | S22 | 1 – 2 | 20 | 2 x 100 |
| | | 1 – 2 | 22 | 2 x 75 |
| | | 2 – 3 | 50 | 2 x 45 |
| L3 | S23 | 1 – 2 | 20 | 2 x 100 |
| | | 1 – 2 | 22 | 2 x 75 |
| | | 2 – 3 | 50 | 2 x 45 |
| L4 | S24 | 1 – 2 | 20 | 2 x 100 |
| | | 1 – 2 | 22 | 2 x 75 |
| | | 2 – 3 | 50 | 2 x 45 |

Note:

In case the ADC-4001M adapter with a grounded intrinsically safe barrier is applied in a side line, it is necessary to disable the earth fault signalling by removing the S4 jumper on the MSL-1M-42 module. The MSL-1M-42 module communicates with the PSC-43 module receiving information about the current configuration of addressable elements in detection lines and about commands to be accomplished (switch an element or line on/off, reset an element, etc.), in return transmitting processed data concerning addressable elements and detection line status.

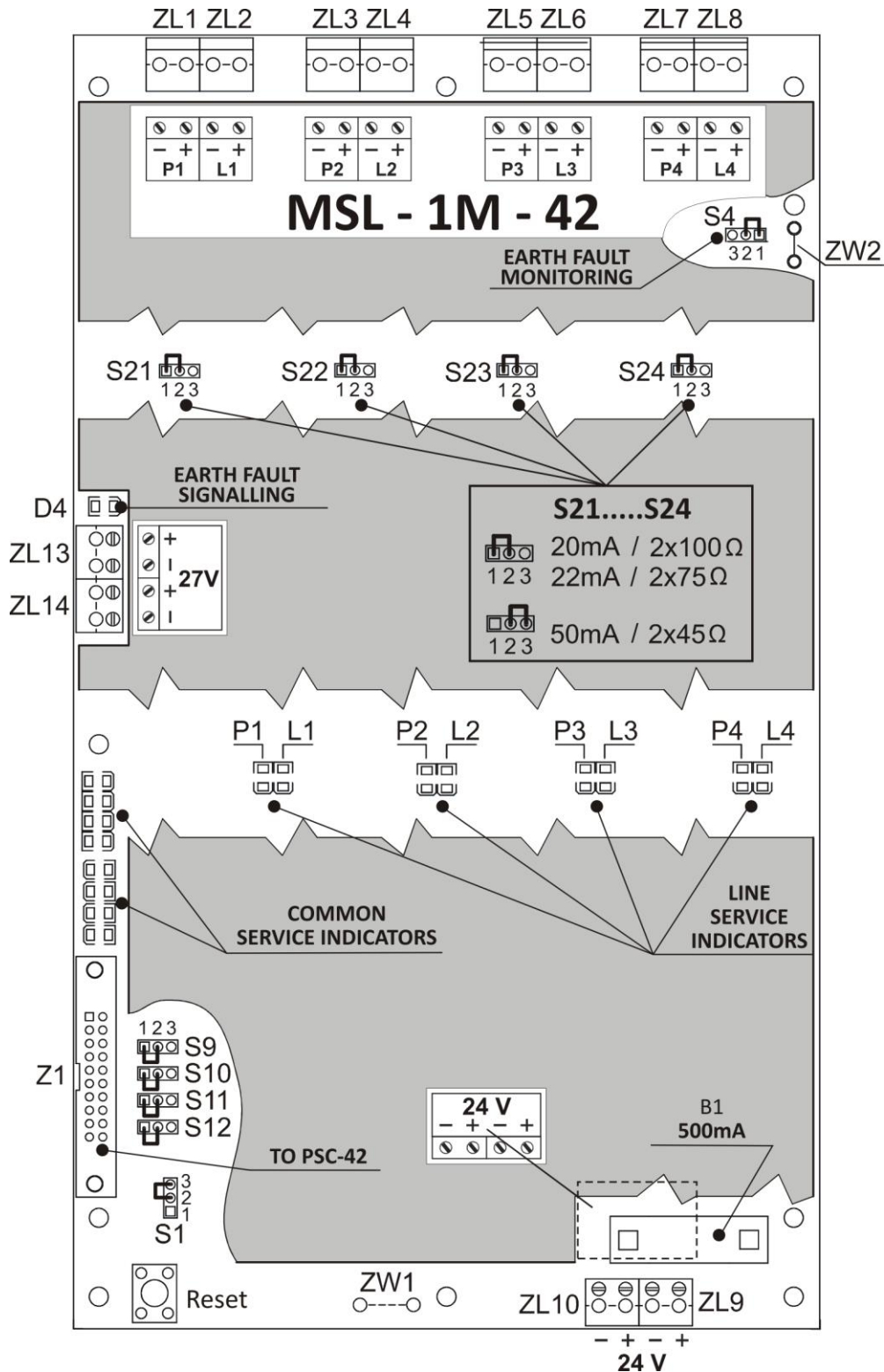

Fig. 5.3 MSL-1M-42 line module view

5.5 PPW-42 programmable outputs/inputs module

5.5.1 General description

The programmable outputs/inputs module enables connection of external devices to the control panel, transmission of alarm and fault signals, other devices operation supervision, etc. Extensive outputs software makes this module flexible, ensuring any configuration of installation.

The PPW-42 module is furnished with the following outputs:

- 8 relay outputs with switchable contacts (PK),
- 1 signal output (potential) supervised (LS) of 0.5 A load capacity,
- 1 signal output (potential) supervised (LS) of 100 mA load capacity.

The PPW-42 module is equipped with 2 monitoring inputs (LK).

The relay outputs marked with PK2 ...PK8 numbers can be supervised (in non-actuation condition) as for the relay output line break or short circuit. The relay output line is supervised if the line continuity monitoring is declared during the relay programming.

The output line is properly supervised if in the quiescent mode the controlled device is powered by voltage of the 6...30 V range and relevant output monitoring jumper is set in the 2 – 3 = 'YES' position (see Fig. 5.5).

Note:

The line continuity monitoring system for relay outputs consumes less than 1 mA of current from an external device, which may cause its slight actuation. If such the situation is not allowable, the line continuity monitoring circuit should be disabled within the software (no output monitoring declared) and hardware (output monitoring jumper in 1-2 = "NO" position).

5.5.2 PK relay outputs and LS signal outputs

The PK1 relay output (PU - fault relay) is permanently programmed and operates in the following manner: the output is activated if the control panel is in the fault mode (also during a complete power outage).

Other POLON 4200 control panel outputs, both relay outputs (PK2 ÷ PK8) and supervised potential outputs (LS1 ÷ LS2) may be defined as:

- TYPE 0 - inactive output;
- TYPE 1 - output to fire alarm devices;
- TYPE 2 - output to fire alarm transmission devices (monitoring);
- TYPE 3 - output to protection devices;
- TYPE 4 - fault signalling output (to fault signal transmission devices);
- TYPE 5 - information output;
- TYPE 6 - reset output (only for relays).

In order to program individual physical potential or relay outputs, such parameters as: output type, actuation variant, proper setup options selection (zone numbers, occurrence selection, output actuation time program setting, etc.) must be defined in applicable output setup menu windows.

Depending on how a given output type is defined, it is possible to assign a given variant and defined actuation time parameters to this output.

Table 5.2

| Relay | Condition | Relay contacts status |
|----------|-----------------------------|-----------------------|
| PU (PK1) | No fault, quiescent mode | Closed C-NO |
| | General fault | Closed C-NC |
| PK2÷PK8 | Lack of actuation criterion | Closed C-NC |
| | Actuation criterion | Closed C-NO |

Output actuation time parameters

Every output: both PK relay output (except for PU) and LS potential output can operate with a defined actuation time program (also depending on the defined output time).

It may depend on the global parameters (T1, T2 and T3), individual parameters (Top) or a combination of these parameters, depending on the programming types and variants.

The meaning of time parameters:

- T1 – the time necessary to confirm the 1st stage alarms;
- T2 – the time necessary to recognise the situation after an alarm is confirmed, or possibly to reset (after this time, the control panel switches to the 2nd stage alarm mode);
- T3 – the alarm output (TYPE 1) actuation delay time from the moment the 1st stage alarm is evoked. The T3 is reset (alarm outputs are immediately activated) after the control panel enters the 2nd stage alarm mode;
- Top - individually programmable output actuation delay time.

Parameter range: T1, T2, T3, Top – from 00'00'' to 10'00''.

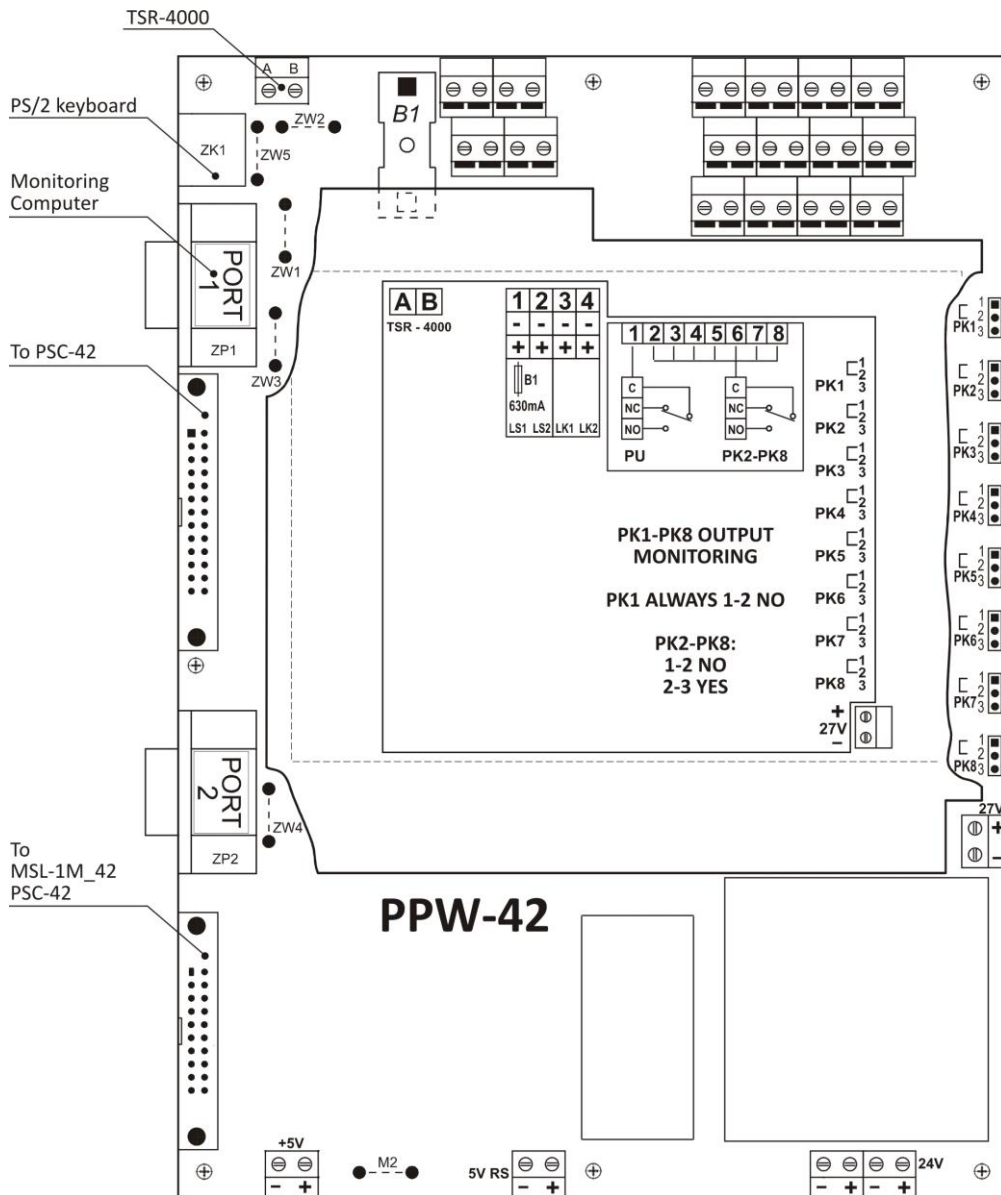

Fig. 5.5. PPW-42 programmable outputs/inputs module

Specification of the LS supervised potential output lines

The potential outputs are defined as supervised outputs, i.e. they are tested by measuring the characteristic resistance of a potential line during quiescent mode in order to detect line faults with the reversed polarisation (negative) of the output voltage. The range of potential lines resistance (including the connecting cables resistance) is 2.7 kΩ - 16 kΩ. If the line resistance is outside the defined range, this situation is interpreted as a fault mode and is appropriately signalled in the control panel. After the output is actuated (according to a proper actuation variant), the output voltage polarisation is positive.

Output actuation criteria

Tables 5.3 ÷ 5.7 present the PK and LS outputs programming possibilities.

Notes:

1. "Zone 0" means the dependence on the 'union' of events from all control panel zones.
2. "The union of events" means that an actuation criterion is fulfilled if at least one event happens.
3. The total number of zones, EKS and EWK elements assigned to all executive outputs and SAL type elements in the control panel must not exceed 64,000.

5.5.3 Output to fire alarm devices (TYPE 1)

Outputs to fire alarm devices (e.g. acoustic signalling devices) can be programmed in the following variants:

Table 5.3

| Variant | Zone Nos | Time Parameters | Actuation Criterion |
|---------|----------|-----------------|--|
| 1 | — | T3 | 1 st stage alarm in control panel or activation with ACTIVATED push button in ALARM DEVICES field |
| 2 | 0 ÷ 256 | T3 | 1 st stage alarm in assigned zones |

Note:

The countdown of the delay time is discontinued (T3 time is reset during the countdown time) and the outputs to alarm devices are activated immediately after the control panel enters the 2nd stage alarm mode. After setting the T3 parameter at its maximum level (10 minutes), the actuation criterion may be dependent on "the 2nd stage alarm only".

At any time (in quiescent mode), the outputs to fire alarm devices can be activated (if this setting has not been permanently program disabled) or deactivated at an appropriate access level by using the push button on the control panel front panel: ALARM DEVICES – ACTIVATED.

During a fire alarm, the above mentioned push button is used to deactivate and reactivate alarm devices (excluding the devices permanently program disabled).

The output activation is signalled by the red LED in the following field:

ALARM DEVICES – ACTIVATED.

The output disablement is signalled by the yellow LED in the following field:

ALARM DEVICES – DISABLED - flashing - some outputs disabled; steady - all outputs disabled.

The output fault is signalled by the yellow LED in the following field:

ALARM DEVICES – FAULTY.

5.5.3 Output to fire alarm transmission devices (TYPE 2)

The outputs to fire alarm transmission devices may be programmed as follows:

Table 5.4

| Variant | Zone Nos | Time Parameters | Actuation Criterion |
|---------|----------|-----------------|--|
| 1 | — | T1, T2 | 2 nd stage fire alarm at control panel |
| 2 | 0 ÷ 256 | T1, T2 | 2 nd stage fire alarm in assigned zones |

At any time, the outputs to fire alarm transmission devices may be disabled and re-enabled (excluding outputs permanently program disabled) at an appropriate access level by using the push button on the control panel front panel marked:

ALARM TRANSMISSION DEVICES – DISABLED.

The output activation is signalled by the red LED in the following field:

ALARM TRANSMISSION DEVICES – ACTIVATED.

The output disablement is signalled by the yellow LED in the following field:

ALARM TRANSMISSION DEVICES – DISABLED - flashing - some outputs disabled; steady - all outputs disabled.

The output fault is signalled by the yellow LED in the following field:

ALARM TRANSMISSION DEVICES – FAULTY.

5.5.5 Output to protecting devices (TYPE 3)

The outputs to protecting devices can be programmed in the following variants:

Table 5.5

| Variant | Zone Nos | Time Parameters | Actuation Criterion |
|---------|----------|-----------------|---|
| 1 | — | T _{op} | 1 st stage alarm at control panel |
| 2 | — | T _{op} | 1 st stage alarm at control panel until acknowledgement |
| 3 | — | T _{op} | 2 nd stage fire alarm at control panel |
| 4 | — | T _{op} | 2 nd stage alarm at control panel until acknowledgement |
| 5 | 0 ÷ 256 | T _{op} | 1 st stage alarm in assigned zones |
| 6 | 0 ÷ 256 | T _{op} | 1 st stage alarm in assigned zones until acknowledgement |
| 7 | 0 ÷ 256 | T _{op} | 2 nd stage alarm in in assigned zones |
| 8 | 0 ÷ 256 | T _{op} | 2 nd stage alarm in assigned zones until acknowledgement |

5.5.6 Fault/technical alarm signalling output (TYPE 4)

The output of the fault signalling system can be programmed in the following variants:

Table 5.6

| Variant | Zones/EKS/EWK Numbers | Time Parameters | Activation Criterion |
|---------|-----------------------|-----------------|--|
| 1 | — | T _{op} | General fault at control panel |
| 2 | — | T _{op} | General non-maskable fault at control panel |
| 3 | — | T _{op} | General technical alarm at control panel |
| 4 | — | T _{op} | General fault at control panel until acknowledgement |

| | | | |
|----|---------|-----------------|---|
| 5 | — | T _{op} | General non-maskable fault at control panel until acknowledgement |
| 6 | — | T _{op} | General technical alarm at control panel until acknowledgement |
| 7 | 0 ÷ 256 | T _{op} | Fault in zone |
| 8 | 1 ÷ 50 | T _{op} | EKS 1 ÷ 2 inputs fault |
| 9 | 1 ÷ 50 | T _{op} | EKS 1 ÷ 2 inputs non-maskable fault |
| 10 | 1 ÷ 50 | T _{op} | EKS 1 ÷ 2 inputs technical alarm |
| 11 | 0 ÷ 256 | T _{op} | Fault in zone until acknowledgement |
| 12 | 1 ÷ 50 | T _{op} | EKS 1 ÷ 2 inputs fault until acknowledgement |
| 13 | 1 ÷ 50 | T _{op} | EKS 1 ÷ 2 inputs non-maskable fault until acknowledgement |
| 14 | 1 ÷ 50 | T _{op} | EKS 1 ÷ 2 inputs technical alarm until acknowledgement |
| 15 | — | T _{op} | Potential outputs fault |
| 16 | — | T _{op} | System fault |
| 17 | — | T _{op} | Power supply fault |
| 18 | — | T _{op} | Potential outputs fault until acknowledgement |
| 19 | — | T _{op} | System fault until acknowledgement |
| 20 | — | T _{op} | Power supply fault until acknowledgement |
| 21 | 1 ÷ 50 | T _{op} | EWK inputs 1 ÷ 8 fault |
| 22 | 1 ÷ 50 | T _{op} | EWK inputs 1 ÷ 8 technical alarm |

Note:

Variants 1, 2, 4, 5 and 15, 16 must not be assigned to LS potential lines as it may result (if this line is broken or shorted) in improper operation of these outputs.

5.5.7 Information output (TYPE 5)

The information output can be programmed to transmit information about the system (control panel and line elements) condition, not being the fire alarm or fault mode.

Table 5.7

| Variant | Time Parameters | Actuation Criterion |
|---------|-----------------|--------------------------------|
| 1 | — | Disablement mode |
| 2 | — | 1 ÷ 256 zones disablement mode |
| 3 | — | Testing mode |
| 4 | — | 1 ÷ 256 zones testing mode |
| 5 | — | Personnel absent |

5.5.8 Reset output (TYPE 6)

The reset output supports only relays and its objective is to generate a reset impulse (lasting for approx. 4 seconds), after a fire alarm reset. This type can be used, e.g. to power supply or reset of detectors requiring a separate power supply, e.g. flame detectors manufactured by Det-Tronics.

5.5.9 LK monitoring input

Each of the POLON 4200 control panel two monitoring inputs for can be programmed in the following variants:

- to monitor the external devices actuation after receipt of an actuation criterion from a declared relay output or potential output (for TYPE-1, TYPE-2, TYPE-3 outputs);
- to monitor the external devices proper operation;
- as a technical alarm input.

The input condition is analysed on the basis of the monitoring line characteristic resistance measurement (Table 5.8). The range of the characteristic resistance (including the connecting cables resistance) is 2.7 kΩ - 16 kΩ. If the monitoring line resistance is outside the defined range, this condition is interpreted as an acknowledgement of external devices actuation (variant 1) or external devices fault (variant 2).

In the control panel, improper conditions are signalled as faults in the following cases:

- no acknowledgement of external device actuation at an active actuation signal of a declared relay or potential output;
- detection of an external device fault.

Table 5.8

| Variant | Function | PK or LS assigned output | Mode dependent on detection line characteristic resistance | |
|---------|----------------------|--------------------------|--|--|
| 1 | Actuation monitoring | Non-activated | Quiescent mode 2k7 < R < 16 k | Technical alarm R < 0.9 k R > 30 k |
| | | Activated | Non-maskable fault 2k7 < R < 16 k | Technical alarm R < 0.9 k R > 30 k |
| 2 | Operation inspection | - | Quiescent mode 2k7 < R < 16 k | Non-maskable fault R < 0.9 k R > 30 k |

| | | | | |
|--|-----------------|---|------------------------------------|---|
| 3 | Technical alarm | - | Quiescent mode $2k7 < R < 16 k$ | Technical alarm $R < 0.9 k$ $R > 30 k$ |
| R – characteristic resistance of detection lines together with connecting cables | | | | |

Monitoring inputs programming variants

Variant 1:

A monitoring line input can be assigned to one of the previously declared outputs: relay or potential, defined as TYPE-1, TYPE-2, TYPE-3. Then, this input can be used to monitor external devices actuation after receiving an actuation criterion from the declared output. Monitoring is enabled for approx. 60 seconds after the monitored output is actuated (permissible time of the controlled device actuation delay). Examples of using a monitoring input assigned to a relay or potential output are shown in Fig. 5.6 and 5.7.

Variant 2:

A monitoring line input can be programmed to monitor efficiency of, e.g. external devices. It consists in connection the normally opened contact of this device in parallel with the end-of-line resistor in the monitoring line circuit. The correct condition is observed when the monitoring line characteristic resistance is within the 2.7 k Ω - 16 k Ω range. An example of connecting the contact in the monitoring line is presented in Fig. 5.8.

Variant 3:

A monitoring line input can be programmed as a general purpose technical alarm input to be used by the installer for individual needs.

It operates as an external devices efficiency monitoring input. In case any resistance within the line technical alarm range is detected, the technical alarm is evoked. Applicable examples are presented in Fig. 5.7 and 5.8.

Monitoring line inputs programming

Table 5.9

| Variant | Monitored output type | Monitored output number | Monitoring type |
|---------|-----------------------|--------------------------|--------------------------|
| 0 | | | Inactive output |
| 1 | 1-PK, 2-LS | $2 \div 8$ or $1 \div 2$ | KZ actuation monitoring |
| 2 | - | - | KS efficiency inspection |
| 3 | - | - | AT technical alarm |

Note:

Outputs defined as TYPE 4 should not be assigned to monitoring lines. It can result in incorrect interpretation of the current condition if an actuation variant is assigned to a fault of monitoring or potential lines circuits.

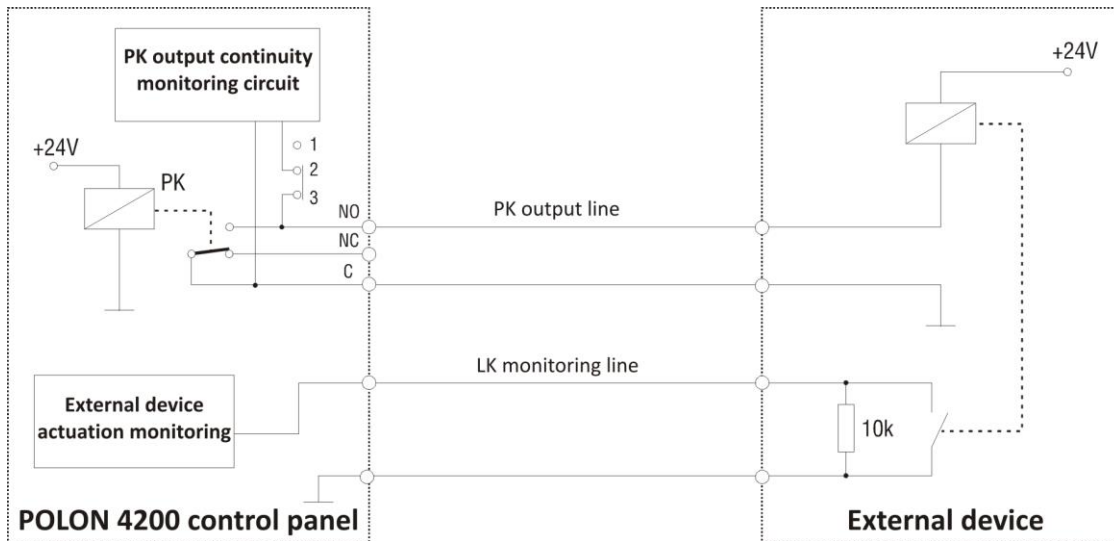

Fig. 5.6 Exemplary use of monitoring line assigned to relay output

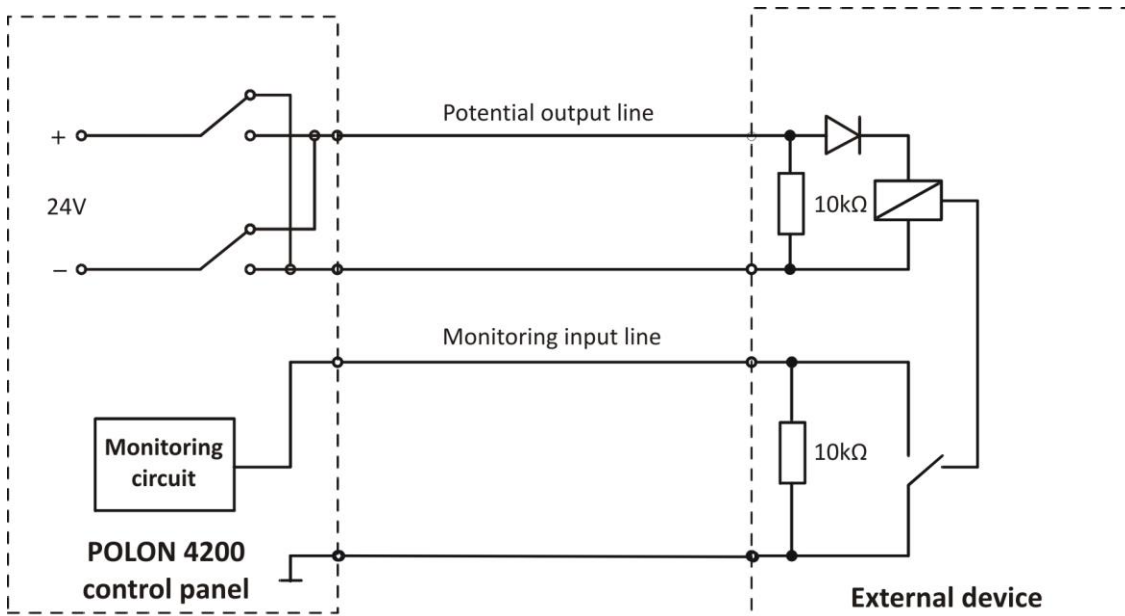

Fig. 5.7 Exemplary use of monitoring line assigned to potential output

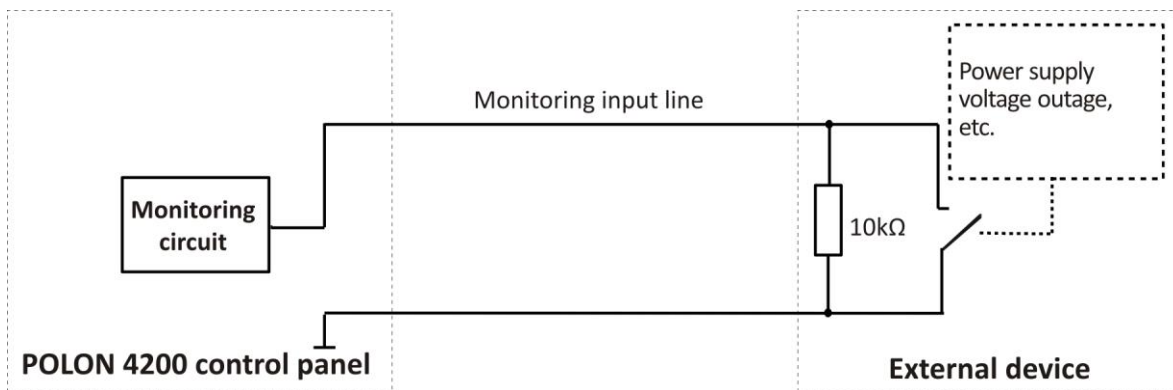

Fig. 5.8 Exemplary connection of external device contact into monitoring line

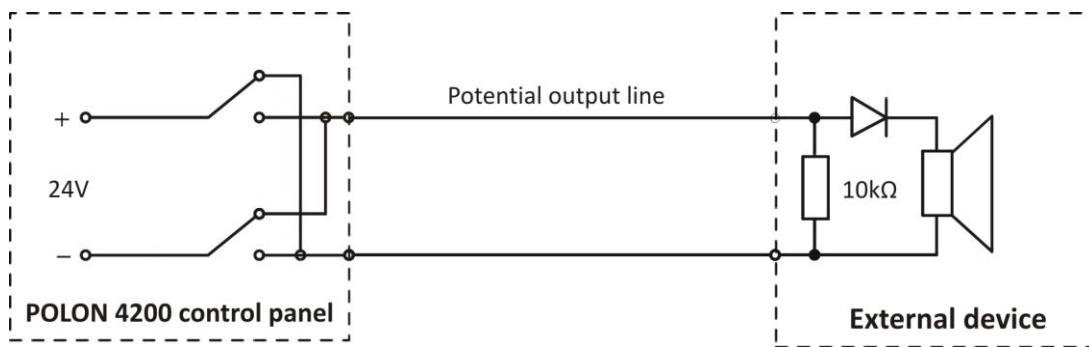

Fig. 5.9 Exemplary use of potential line for acoustic signalling device actuation

5.5.10 PORT 1 and PORT 2

Two serial ports intended for communication with a computer are placed on the module:

- PORT 1 – of RS-232 standard (galvanic isolated from the control panel),
- PORT 2 – universal USB serial port.

The PORT 1 (RS-232) connection to an external device should be made through a standard computer cable used for connection of standard serial outputs of COM type.

The PORT 2 (USB) connection to an external device should be made through a standard computer cable used for connection of USB interface hardware.

The serial ports (PORT1, PORT2) are declared (in accordance with the PM) and can operate as:

PORT TYPE - 0

Means: non-declared port – inactive.

PORT TYPE - 1

Used for configuration transmission or readout using a computer – it is necessary to utilize the POLON 4200 control panel configuration special software.

Transmission speed 9600 b/s.

PORT TYPE – 2

Used for interoperation with a monitoring station utilizing the POLON 4000 system PMC-4000 digital monitoring protocol.

Declared transmission speed: 2400 b/s, 4800 b/s, 9600 b/s.

The PMC-4000 protocol enables to supply a monitoring station with information regarding the following events/occurrences:

fire alarms;

- technical alarms and their resets;
- 2nd stage alarms;
- reset;
- acknowledgement;
- faults and their resets;
- non-maskable faults and their resets;
- tests and their resets;
- disablement and its resets;
- output actuation and its resets.

Moreover, a permission for the control panel remote handling (see PM) enables the monitoring station to acknowledge remotely an alarm or fault and reset remotely an alarm.

A full description of the PMC-4000 protocol is provided in a separate document.

5.5.11 TSR-4000 terminal output

The PPW-42 module is equipped with one output of the RS-485 standard (galvanic isolated from the control panel) to connect the TSR-4000 parallel signalling terminals (up to 16 pieces). The terminal connection consists in connection of the clamps marked with 'A' and 'B', located on the PPW-42 module, with appropriate clamps placed on the TSR-4000 terminal. The control panel 'A' and 'B' clamps should be connected with the corresponding 'A' and 'B' clamps of the terminal (the 'A' clamp is linked with the 'A' clamp and the 'B' clamp is linked with the 'B' clamp). In a similar way, the 'A' and 'B' clamps of the terminal should be connected to the 'A' and 'B' clamps of the next terminal and so on.

The maximum length of the cable between the control panel and the last terminal should not exceed 1,200 m. It is recommended to use the YnTKSYekw. 1 x 2 x 0.8 mm installation cable or its equivalent. The detailed description of the terminals connection is contained in the TSR-4000 Parallel Signalling Terminal manual (ID-E305-001E). The TSR-4000 terminal can be also attached using optic-fibre converters (see the terminal I&M manual).

Note:

An optic-fibre converter, powered by the control panel voltage, causes the serial ports galvanic isolation destruction. Such the elimination may result in:

- **in the case of connection of a PC powered from the mains – the earth fault indication and in a final case – the PPW-42 module outputs damage (the difference between the 'masses' of the computer and control panel), therefore the PC connected to the control panel should be power supplied from the same source as the control panel;**
- **the above described occurrences in case of connection of any monitoring devices powered from the mains without interface isolation.**

Taking the above notes into consideration, it is recommended to use for a fibre-optic converter power supply a galvanic isolated DC/DC converter connected to the control panel voltage.

5.5.12 Computer keyboard output

The PPW-42 module contains a ZK1 socket to connect a PS/2 standard computer keyboard that can be used instead of the keypad in the handling area, and is necessary to enter the user messages. The keyboard declaration is not necessary.

5.6 DR-48 Printer

The DR-48 thermal printer is used to register (in a printout form, on a paper band) the events which take place when a facility is monitored by the POLON 4200 control panel.

The following occurrences are considered as events:

- alarms;
- faults and their removals;
- fault or alarm acknowledgements;
- switching the control panel operating mode from PERSONNEL PRESENT to PERSONNEL ABSENT and vice versa;
- delays switching on and off;
- alarm resets;
- testing;
- disablements;
- access to the configuration.

Every message on any event contains its occurrence date and time and a short description. Additionally, if a text message is assigned to a zone (user's text), during an alarm of this fire protection zone element, apart from the line number, element number and zone number, the assigned message is also printed out.

The POLON 4200 control panel stores 2,000 latest events that have been signalled. The stored events, sorted by their date and time of occurrence can be printed after choosing a proper function on the keypad according to the programming manual (PM).

On-going events recording on the paper tape and printing out the event memory contents is possible only when the printer is assigned for operation in accordance with the programming manual (PM). Regardless of assigning the printer to operation, the event memory is constantly updated.

Some exemplary event printouts are shown below:

FAULT !

TERMISTOR IN TUN-4046 !

L-1 E-8 ZONE-31

2007-01-30 / 14:53:18

ACKNOWLEDGEMENT !

2007-01-30 14:54:00

** 1ST STAGE FIRE ALARM ! **

2007-01-30 17:20:00

FIRE ALARM WITH TUN-4046 !

L-1 E-98 ZONE-25

CONFERENCE HALL

2ND FLOOR

2007-01-30 17:20:00

ACKNOWLEDGEMENT !

2007-01-30 17:22:30

----- ALARMU RESET -----

2007-01-30 17:25:17

The printer is equipped with a thermal paper roll (width 80 mm and max. diameter \varnothing 50 mm).

On a board at the back of the printer, two mono-stable push buttons (PAPER and RESET) are located - used for the following operations:

- printer paper out feed using the PAPER push button;
- printer test: press the PAPER and RESET buttons simultaneously; next, release the RESET button; then, after 1 second, release the PAPER button;
- printer controller restart after pressing the RESET push button.

In order to replace a paper roll:

- open the printer mechanism with the lever 1;
- take the used roll away from the holder and replace it with a new one;
- insert the paper into the printer mechanism guide slit so that the thermo-sensitive surface is visible while inserting it into the printing mechanism guide slit;
- close the printer mechanism using the lever 1;
- press the PAPER push button to pull the paper into the mechanism.

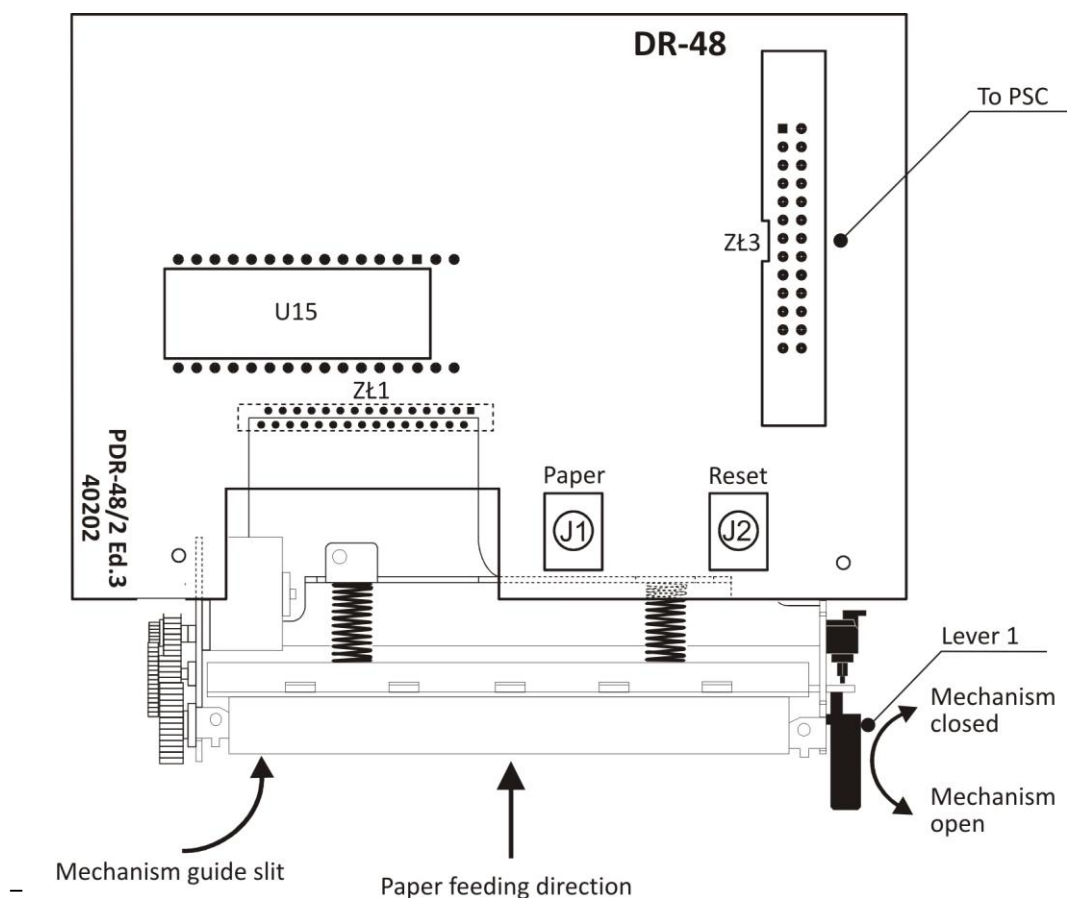

Fig. 5.10 DR-48 printer view from control panel inside

5.7 Power Supply Module

The POLON 4200 control panel design enables its power supply from two sources:

- AC 230 V/50 Hz – as the basic power source;
- DC 24 V – a reserve power source (battery cluster).

The MZ-4212 power supply module (nominal voltage at 30 V/2 A) is equipped with a mains switch. It is designed as a separate block located in the right lower corner of the control panel and supplies all control panel modules and facilitates operation with the battery cluster.

In the case of 230 V/50 Hz mains power outage, the control panel is automatically switched to power supply provided by the battery cluster and the device operation remains uninterrupted. When the mains power supply is restored, the power supply unit recharges batteries until the "recharging complete" voltage is obtained and switches to the buffering mode.

Apart from the basic functions including supplying power to the control panel, recharging or the battery cluster buffering, the power supply module protects the control panel powered circuits.

The MZ-4212 power supply module is equipped with:

- terminal blocks to connect:
 - 230 V/50 Hz mains voltage
 - battery cluster (AKU), protected by the BZ1/3.15 A fuse
- terminal blocks of the following voltages:
 - the control panel 24 V operation voltage, protected by the BZ2/1 A fuse
 - external device power supply 24 V voltage, protected by the BZ3/1 A fuse.

The power supply module is equipped with the following protection, monitoring and signalling circuits:

overvoltage circuit - actuated when the output voltage increases over 33 V - 35 V, which results in permanent power supply unit disconnection. In order to remove the results of the protection element actuation and return to the normal operation condition, the power supply unit must be disconnected from the mains for approx. 5 seconds;

current limiting circuit - actuated when the power supply unit is overloaded;

correct operation indication – a green OK diode is lit;

230 V/50 Hz voltage monitoring circuit;

battery charging indication - a green diode is lit;

battery efficiency monitoring circuit;

control panel earth fault indication

low voltage detection circuit – actuated when the battery voltage drops below 22 V \pm 1 V.

An outage of the mains voltage, the battery cluster voltage or a fuse burnout is signalled in the TSO-4200 panel with the collective FAULT diode indication and the POWER diode pulse light and relevant acoustic signal. Fault readout can be carried out using the FAULT push button in accordance with the PM.

The POLON 4200 control panel maximum current consumption in the quiescent mode amounts to 0.4 A/24 V.

The user's current should not exceed:

- in the quiescent mode – 0.1 A/24 V;
- in the alarm mode – 0.6 A/24 V (together with the LS signalling lines).

5.8 Control panel interoperation with battery cluster

The POLON 4200 control panel can interoperate with a battery cluster comprising of two 12 V leak-proof lead-acid batteries. The battery cluster must be connected to the terminals marked as AKU on the MZ-4212 module board.

When choosing the battery size it is necessary to obey the rule that – in a case of the mains voltage outage – its capacity should ensure at least 30-hour control panel operation in the quiescent mode,

and after that a 30-minute alarm. In the quiescent mode the control panel maximum current consumption does not exceed 0.4 A and can be additionally increased by 0.1 A drawn by the user. The battery charging current, equal to the difference between the power supply unit maximum current and the current drawn by the control panel in the quiescent mode, amounts to 1.5 A. It allows – taking into consideration the battery charging non-linear characteristics – to utilise a battery cluster of maximum capacity at 38 Ah. In the alarm mode the control panel maximum current consumption does not exceed 0.5 A and can be additionally increased by 0.6 A value drawn by the user.

The battery cluster can be installed:

- inside the control panel (on the panel bottom on the left side) – 2 x 17 Ah batteries manufactured by Hitachi or their equivalents, that are able to power the control panel for 30 h in the quiescent mode (without additional loads);
- in the PAR-4900 container, in which 2 x 38 Ah batteries can be located ensuring 72 hours of the control panel power supply in the above mentioned conditions).

Installation, operation and disposal of waste batteries should be carried out in accordance with the battery manufacturer manuals. Used batteries should be handed over for recycling in accordance with the regulations in force.

6 ADDRESSABLE DETECTION LINES

6.1 Detection lines types

The POLON 4200 control panel addressable detection lines of the A type are wire damage (short-circuit or break) resistant. This resistance is provided by the line loop shape and short circuit isolators built-in in system addressable elements. Apart from this, it is possible to connect the B type open line – radial one, but in such configuration – according to the regulation in force – it cannot contain more than 32 fire warning devices. In loop-shaped lines, one line break does not eliminate any line element. The control panel, after a damage disclosure, signals it and activates the detection line monitoring from both ends. After the break repair, the fault signalling is automatically removed.

A detection line which operates without a loop forming, is not break-in-line resistant. A break results in switching off the line elements located between the break and the line end.

In radial detecting lines, after a short circuit disclosure, the closest before the short circuit isolator is automatically actuated and the section located behind the isolator is cut off.

In the loop-shape layout, in case of the detection line wires short circuit, two isolators located in the line elements closest to the short circuit occurrence are actuated and – as a result of this – only the section placed between those two elements is cut off. It is not recommended to design detection lines with branches since a break or short circuit in a branch makes the elements located between the damage place and the side line end disconnected, regardless the detection line operates in loop-shaped layout or not. If the side line appears indispensable, it is advised to decrease as much as possible (less than a dozen) the number of the line elements installed in this line.

The POLON 4000 system detection lines should be routed as follows:

1. radial lines without branches,
2. loop-shaped lines with few branches are acceptable, but at least one addressable element should be installed between two neighbouring branches.

Such the lines routing way enables addressable elements automatic configuration.

When designing addressable detection lines, the following program and electric requirements should be observed:

- the number of addressable elements in a detection line must not exceed 64;

- the maximum current consumption of all elements in the quiescent mode:
 - for the detection line resistance of $2 \times 100 \Omega$ - 20 mA,
 - for the detection line resistance of $2 \times 75 \Omega$ - 22 mA,
 - for the detection line resistance of $2 \times 45 \Omega$ - 50 mA
- the resistance of detection line cables must not exceed $2 \times 100 \Omega$ and their load must not exceed 300 nF.

6.2 Addressable elements numbering

In the POLON 4000 system each addressable element possesses a unique 12-digit number, which is also called the factory number, whereas the control panel in its normal operation refers to the addressable elements using a short number (the short number – a figure from 1 ÷ 64 range). During a detecting line configuration, every addressable element factory number is assigned to a consecutive element number.

In the POLON 4000 system addressable elements can be configured in three ways:

6.2.1 Automatic configuration

Elements installed in the main loop are numbered in ascending order from number 1 starting from the clamps marked as 'Lx' until the closest branch. Then the control panel allots consecutive numbers to the elements installed in the side line, until reaches its end. After completing allocation in the side line, it returns to the main line and continues numbering up to the next branch; afterwards the numbering process is performed in the same way as in the previous side line. The procedure is continued until all addressable elements are used up. In this numbering method, the elements are always numbered from 1 up to n.

6.2.2 Configuration with verification

In this option it is necessary, on the basis of the circuit design and the control panel number allocation algorithm, to carry out a pre-declaration, i.e. to assign (from a keyboard or computer file) an element type to each number. Then a verification option should be run at the control panel. In case the element types declared for given numbers are consistent with the element types allocated in accordance with the required algorithm, the control panel automatically gives numbers to the addressable elements.

6.2.3 Manual number allocation

This method allows assigning numbers to addressable elements arbitrarily. Matching factory numbers with element numbers is carried out by typing the element number in the factory number box manually.

Manual number declaration in the whole detection line enables arbitrary elements configuration in this line (numbers allocation can be performed in any order, not necessarily abiding the numeration order).

Notes:

The ADC-4001M adapter with incorrectly assigned number can produce a detecting line overload. It is necessary to take the adapter out from its base and wait for at least 5 minutes. Reinstalled adapter shall draw only 150 μA from the line (the side line is automatically blocked). Before the adapter side line re-enablement, it should be assigned a proper operation mode in accordance with the Programming Manual. Since wireless radio detectors create a line branch, automatic configuration and configuration with verification are possible only in the case of the adapter installation in the detection line. If the adapter is installed in a radial line, its configuration should be carried out manually.

6.3 Design guidelines

Due to installation operation reliability, the loop-shaped detection line routing system should be applied. Radial lines should be used only exceptionally (e.g. in case a small number of detectors must be installed in a long distance).

When designing a detection line, each addressable element must be ascribed with its own address (element number), under which it shall be identified by the control panel. In order to assure the installation project clarity and service facilitation, it is recommended that the consecutively installed elements possess consecutively increasing addresses – best if assigned in accordance with the control panel number allocation algorithm, which is utilized during automatic configuration.

The ADC-4001M adapters are fitted with an illuminating diode that signals a side line detector triggering. Therefore, such adapter can be installed in front of premises, instead of an actuation indicator. Regardless of this, it is possible to attach the WZ-31 actuation indicators to the ADC-4001M side line detectors as well as to 4043 and 4046 model range detectors.

It is recommended to use screened wires in the POLON 4000 system.

In the installation design process it is important to meet all requirements contained in technical specifications, it is necessary to pay special attention to the detection line capacity. The detection line appropriate resistance should be provided as well as resistance between neighbouring short circuit isolators.

7 ALARMING SYSTEM/STRUCTURE

The POLON 4200 control panel alarming system and other programmable parameters should be determined at the circuit design stage. For this purpose, taking into consideration the protected premises conditions, it is necessary to fill in the designer's tables, which constitute an inseparable part of the design and should be available to the circuit commissioning and servicing teams.

The alarming system programming is performed as follows:

1. declaration of addressable elements, zone assignment, operation modes, and groups,
2. declaration of alarm variants, user messages,
3. alarm general parameters programming (T1, T2, T3 times),
4. programming actuation variants and monitoring of all inputs and outputs of monitoring and controlling elements.

7.1 Detection zone

Addressable elements must be program divided into detection zones. It is possible to create up to 256 zones in the control panel. According to the standard, up to 32 line elements can be assigned to one zone. Zones, which are assigned with no element, are called empty or inactive. Zones are created in order to describe any supervised area with a defined set of line elements, in the way that enables their installation place. Moreover, a zone enables programming a proper alarm variant that eliminates false alarms in case of premises of high level of alarm warning devices accidental actuation probability.

The area of one zone can be divided into two alarm warning device group, marked as A and B. Every fire warning device must be assigned to one of those groups at the programming stage. Groups of fire elements (A/B) are created in order to program a group coincidental alarm variants, at the most eliminating false alarms.

Every zone can be personalized with a text message (the user message) of up to two text lines of 32 characters each. In case an alarm is received from a particular zone, the text is displayed on the LCD, indicating exact fire location.

7.2 Addressable elements declaration

The control panel receives information and control operation of addressable elements, which are declared (operationally assigned) by the user. In the standard configuration (that is received by the user with the control panel) no addressable element is declared. Until declaration, no signal concerning type and status of line elements is being received but every 2 minutes the control panel checks coherence of the elements installed in the addressable detection line with the declared ones and – in case an inconsistency is revealed – it signals a fault, which type may be red out.

An addressable element declaration consists in defining its address of:

- line number,
- element number,

and stipulating the following data concerning this address:

- factory number (entering the number either manually or using a bar code reader),
- zone number or logical number:
 - zone number from 1 ÷ 256 range in the case of a fire warning device,
 - logical number from 1 ÷ 50 range for the EKS-4001, SAL-4001, EWS-4001, EWK-4001, UCS 4000, UCS 6000 type elements,
- group (within the stated zone) A or B in the case of a fire warning device,
- operation mode (depending on particular possibilities and needs, for each type of elements).

An addressable element declaration can be preceded by an automatic configuration or configuration with verification; those operations enable assignment of consecutive elements numbers to their factory numbers.

An improper type assignment to an addressable element is revealed and indicated by the control panel as a fault.

Note:

1. Any quantity of fire warning devices can be installed in one detecting zone but it is recommended to install not more than 32 fire warning devices.
2. Logical numbers for any line element can be repeated only in the case of different element types, e.g. the 35 logical number can be possessed at the same time by one element of the device group: EKS, EWK, EWS, SAL and UCS.

7.3 Assigning alarm parameters to zones

In order to group addressable elements, installed in the supervised premises, the territory is divided into zones (separated parts of the premises, rooms, etc.) in the POLON 4200 control panel it is possible to create up to 256 detection zones. Every zone can be described with the user message composed of two text lines up to 32 characters each.

A zone creation means assigning an addressable element with a short number to the zone number, according to the PM.

The POLON 4200 control panel provides a possibility to choose an alarm method for a particular zone, one of 14 available ones.

Alarm variants should be chosen so that they guarantee early and at the same time dependable fire danger detection. Alarm variant descriptions are contained in p. 8.1 of this Manual. As default, the control panel is programmed with the variant 2 in all zones. The alarm variants can be divided into two groups considering an alarm triggering way:

1. one-stage alarms (variants 1, 3, 4, 7, 9, 11, 17),
2. two-stage alarms (variants 2, 5, 6, 8, 10, 12, 13, 14, 15, 16).

Alarming is performed according to the programmed variants only in the case of PERSONNEL PRESENT operation mode. If the PERSONNEL ABSENT mode is set, alarming shall be performed in all zones, regardless of the programmed variants, pursuant to one-stage variant (variant 1) that immediately generates the 2nd fire alarm at the control panel. Alarming as per the variants is not

executed also in the case of a manual call point (ROP) actuation since such a situation is treated in different way than signals by other addressable element – the control panel evokes the 2nd fire alarm without any delay. The program alarm variants assignment to zones should be carried out together with the user message declaration according to the PM.

7.4 EKS-4001 monitoring and controlling elements declaration

The EKS-4001 monitoring and controlling element (hereinafter called 'EKS') is a line element that enables activation and supervising of fire protection devices, e.g. smoke exhaust dampers, doors, sounders, optical signalling devices, etc. A single EKS (assembled in cases containing 1, 2 or 4 devices) is equipped with one controlling relay output and two monitoring inputs. Each of two monitoring inputs can indicate – depending on the programmed operation mode and specific resistance – one of the following modes:

1. supervision,
2. fault,
3. non-maskable fault,
4. technical alarm.

The EKS proper programming consists of a line element declaration (similarly to fire warning devices) and its assignment to a logical number.

The EKS logical number is a figure from the 1 ÷ 50 range, which is assigned to the element in order to enable the EKS variant declaration depending on various events in the control panel, and to assign appropriate user messages. Each EKS type element can be assigned only to one logical number and reversely. In programming meaning – with some simplification – it can be stated that for the EKS element a logical number is an equivalent of a zone for fire elements. The EKS element is linked with actuation variants and the user messages for monitoring inputs just through the logical number.

The EKS-4001 operation way is a resultant of the element programmed operation mode and the output relay activation variant.

The entire EKS-4001 programming process is completed in two stages:

1st stage:

The EKS-4001 declaration consisting in assigning:

- an element number (1 ÷ 64) using the automatic configuration or configuration with verification or manual configuration procedures;
- a logical number (1 ÷ 50);
- an operation mode (it is set by default but may be changed – see below).

The EKS-4001 operation mode is defined by the following element parameters (standard mode in bold print):

- output line continuity monitoring (**YES** or NO);
- input 1 - actuation monitoring (YES (40 sec.) or YES (70 sec.) or YES (130 sec.) or **NO**);
- input 2 - actuation monitoring (YES (40 sec.) or YES (70 sec.) or YES (130 sec.) or **NO**);
- input 1 operation method (NC or **NO**);
- input 2 operation method (NC or **NO**);
- output relay actuation delay (**0 s** or 30 s, or 60 s, or 90 s).

The set of parameters defining an operation mode is directly connected with a line element and is programmed while declaring the EKS element as a line element. The operation mode may always be changed in the program.

2nd stage:

The EKS-4001 logical configuration consisting in assigning:

- a variant to the previously assigned logical number;
- a set of assigned zones if it is required by a given variant (from the 1 ÷ 256 range);

-
- a set of assigned inputs of other EKS elements if it is required by a given variant (or own inputs if the variant permits it) – the range of assigned EKS elements: 1 ÷ 50, EKS inputs range: 1 ÷ 2);
 - a set of assigned EWK inputs if it is required by a given variant (range of assigned EWK elements: 1 ÷ 50, EWK inputs range: 1 ÷ 8);
 - user messages for a technical alarm and non-maskable fault of monitoring inputs.

The EKS-4001 output relay activation variants

Table 7.1 lists the EKS output programming possibilities. For variants with additional zone dependencies: the zone number = 0 means a dependence on a 'unit' or 'intersection' (depending on the variant) of events within all zones in a selected control panel.

Table 7.1

| Variant | Zones/EKS/EWK Numbers | Actuation Criterion |
|---------|-----------------------|---|
| 0 | — | inactive output |
| 1 | — | 1 st stage general alarm |
| 2 | 0 ÷ 256 | 'union' of 1 st stage alarms in assigned zones |
| 3 | 0 ÷ 256 | 'conjunction' of 1 st stage alarms in assigned zones |
| 4 | — | 2 nd stage general alarm |
| 5 | 0 ÷ 256 | 'union' of 2 nd stage alarms in assigned zones |
| 6 | 0 ÷ 256 | 'conjunction' of 2 nd stage alarms in assigned zones |
| 7 | — | general fault in control panel |
| 8 | — | non-maskable general fault in control panel |
| 9 | — | general technical alarm in control panel |
| 10 | 1 ÷ 256 | 'union' of faults of assigned EKS inputs |
| 11 | 1 ÷ 256 | 'union' of non-maskable faults of assigned EKS inputs |
| 12 | 1 ÷ 256 | 'union' of technical alarms of assigned EKS inputs |
| 13 | 1 ÷ 256 | 'union' of faults of assigned EWK inputs |
| 14 | 1 ÷ 256 | 'union' of technical alarms of assigned EWK inputs |
| 15 | — | reset output |
| 16 | — | alarming device – 1 st stage general alarm |
| 17 | 0 ÷ 256 | alarming device – 'union' of 1 st stage alarms in assigned zones |

Variant 0

Means lack of the EKS actuation criterion (permanently non-activated output).

Variant 1 – general 1st stage alarm

The output activation is performed in the case of a 1st stage alarm occurrence in the control panel.

Variant 2 – 'union' of 1st stage alarms in assigned zones

The output activation is performed in the case of a 1st stage alarm occurrence in at least one zone that is assigned to this relay.

Variant 3 – 'conjunction' of 1st stage alarms in assigned zones

The output activation is performed in the case of a 1st stage alarm occurrence in at least two zones that are assigned to this relay.

Variant 4 – general 2nd stage alarm

The output activation is performed in the case of a 2nd stage alarm occurrence in the control panel.

Variant 5 – ‘union’ of 2nd stage alarms in assigned zones

The output activation is performed in the case of a 2nd stage alarm occurrence in at least one zone that is assigned to this relay.

Variant 6 – ‘conjunction’ of 2nd stage alarms in assigned zones

The output activation is performed in the case of a 2nd stage alarm occurrence in at least two zones that are assigned to this relay.

Variant 7 – general fault in the control panel

The output activation is performed in the case of a general fault occurrence in the control panel.

Variant 8 – general non-maskable fault in the control panel

The output activation is performed in the case of a general non-maskable fault occurrence in the control panel.

Variant 9 – general technical alarm in the control panel

The output activation is performed in the case of a general technical alarm occurrence in the control panel.

Variant 10 – ‘union’ of faults of assigned EKS inputs

The output activation is performed in the case of a fault occurrence in at least one assigned input of the assigned EKS's. The assigned inputs can be own inputs of the controlled EKS.

Variant 11 – ‘union’ of non-maskable faults of assigned EKS inputs

The output activation is performed in the case of a non-maskable fault occurrence in at least one assigned input of the assigned EKS's. The assigned inputs cannot be own inputs of the controlled EKS.

Variant 12 – ‘union’ of technical alarms of assigned EKS inputs

The output activation is performed in the case of a technical alarm in at least one assigned input of the assigned EKS's. The assigned inputs can be own inputs of the controlled EKS.

Variant 13 – ‘union’ of faults of assigned EWK inputs

The output activation is performed in the case of a fault occurrence in at least one assigned input of the assigned EWK's.

Variant 14 – ‘union’ of technical alarms of assigned EWK inputs

The output activation is performed in the case of a technical alarm in at least one assigned input of the assigned EWK's.

Variant 15 – reset output

The reset output is provided in order to generate a resetting impulse, lasting for ca. 1.5 s, after fire alarm reset. This type can be utilized for instance for power supply and reset of detectors that require a separate power supply, e.g. flame detectors manufactured by Det-Tronics.

Variant 16 – alarming device – general 1st stage alarm

This variant output is treated in the system as an alarming device.

The output activation is performed in the case of a 1st stage alarm occurrence in the control panel or any control panels of the common supervision area.

Variant 17 – alarming device – ‘union’ of 1st stage alarms in assigned zones

This variant output is treated in the system as an alarming device.

The output activation is performed in the case of a 1st stage alarm occurrence in at least zone assigned to this relay.

Output relay actuation variants are programmed only for an EKS that possesses a logical number. In the case of variant 2 and variant 5 application, at least one zone should be assigned to an EKS, whereas in the case of variant 3 and variant 6 application, at least two zones should be assigned. Variants 1 and 4 do not require any zone assignment.

The total assignments number of zones, EKS's and EWK's to all executive outputs and SAL type elements in the control panel should not exceed 64,000.

Note:

An input non-maskable fault can occur only during the output actuation checking. For example, for the 'Yes' mode (40 s), if during 40 s after an output actuation, a technical alarm mode occurs and afterwards the line resistance changes for the one that corresponds to a non-maskable fault, such a non-maskable fault is not signalled yet.

A non-maskable fault is also not signalled if the output is settled at variant 0.

After the standard configuration loading and automatic configuration performance, the EKS elements are assigned to a special logical number 0, which causes that such an element is inactive.

An exemplary drawing showing the EKS-4001 element use is included in the document called 'Fire alarm installation designing using POLON 4000 interactive fire alarm system' and in the EKS-4001 'Installation and Maintenance Manual'.

7.5 EWS-4001 multi-output controlling elements declaration

The EWS-4001 multi-output controlling element (hereinafter called 'EWS') is a line element designed to control various fire protection equipment, e.g. smoke exhaust dampers, doors, sounders, optic signalling devices, etc. The EWS is furnished with 8 controlling relay outputs. It is possible to install up to 20 EWS elements in one detection line.

The EWS proper programming consists of a line element declaration (similarly to fire warning devices) and its assignment to a logical number.

The logical number is a figure from the 1 ÷ 50 range, which is assigned to the element in order to enable the EWS variant declaration depending on various events in the control panel.

Each EWS type element can be assigned only to one logical number and reversely. In programming meaning – with some simplification – it can be stated that for the EWS element a logical number is an equivalent of a zone for fire elements. The EWS element is linked with actuation variants just through the logical number. It is necessary to assign a logical number and actuation variant.

The EWS-4001 operation way depends on output relay activation variants assignment to particular outputs.

The entire EWS-4001 programming process is completed in two stages:

1st stage:

The EWS-4001 declaration consisting in assigning:

- an element number (1 ÷ 64) using the automatic configuration or the configuration with verification or the manual configuration procedures;
- a logical number (1 ÷ 50).

2nd stage:

The EWS-4001 logical configuration consisting in assigning:

- a variant for each output of the previously assigned logical number (see below);
- a set of assigned zones for each output if it is required by a given variant (from the 1 ÷ 256 range).

The EWS-4001 relay output activation variants

Table 7.2 lists the EWS output programming possibilities. For variants with additional zone dependencies: the zone number = 0 means a dependence on a 'unit' or 'intersection' (depending on the variant) of events within all zones in a selected control panel.

Table 7.2

| Variant | Zones Numbers | Actuation Criterion |
|---------|---------------|---|
| 0 | — | inactive output |
| 1 | — | general 1 st stage alarm |
| 2 | 0 ÷ 256 | 'union' of 1 st stage alarms in assigned zones |
| 3 | 0 ÷ 256 | 'conjunction' of 1 st stage alarms in assigned zones |
| 4 | — | general 2 nd stage alarm |
| 5 | 0 ÷ 256 | 'union' of 2 nd stage alarms in assigned zones |
| 6 | 0 ÷ 256 | 'conjunction' of 2 nd stage alarms in assigned zones |
| 7 | — | reset output |

Variant 0

Means lack of the EWS actuation criterion (permanently non-activated output).

Variant 1 – general 1st stage alarm

The output activation is performed in the case of a 1st stage alarm occurrence in the control panel.

Variant 2 – 'union' of 1st stage alarms in assigned zones

The output activation is performed in the case of a 1st stage alarm occurrence in at least one zone that is assigned to this relay.

Variant 3 – 'conjunction' of 1st stage alarms in assigned zones

The output activation is performed in the case of a 1st stage alarm occurrence in at least two zones that are assigned to this relay.

Variant 4 – general 2nd stage alarm

The output activation is performed in the case of a 2nd stage alarm occurrence in the control panel.

Variant 5 – 'union' of 2nd stage alarms in assigned zones

The output activation is performed in the case of a 2nd stage alarm occurrence in at least one zone that is assigned to this relay.

Variant 6 – 'conjunction' of 2nd stage alarms in assigned zones

The output activation is performed in the case of a 2nd stage alarm occurrence in at least two zones that are assigned to this relay.

Variant 7 – reset output

The reset output is provided in order to generate a resetting impulse, lasting for ca. 1.5 s, after a fire alarm reset. This type can be utilized for instance for power supply and reset of detectors that require a separate power supply, e.g. flame detectors manufactured by Det-Tronics.

Note:

Variant 7 is active only for the EWS element outputs 1 and 2.

Output relay actuation variants are programmed only for a EWS that possesses a logical number.

In the case of variant 2 and variant 5 application, at least one zone should be assigned to the EWS, whereas in the case of variant 3 and variant 6 application, at least two zones should be assigned. Variants 1 and 4 do not require any zone assignment.

The total number of assignments of zones to all executive outputs and SAL type elements in the control panel should not exceed 64,000.

Note:

After the standard configuration loading and automatic configuration performance, the EWS elements are assigned to a special logical number 0, and after a number attribution, variant 0 is assigned, which causes that such an element is inactive.

Detailed information concerning the EWS element is contained in the EWS-4001 'Installation and Maintenance Manual'.

7.6 EWK-4001 multi-input monitoring elements declaration

The EWK-4001 multi-output controlling element (hereinafter called 'EWK') is a line element equipped with 8 inputs that enables supervision of fire protection devices, e.g. smoke exhaust dampers, doors, sounders, other mechanical devices, etc. Additionally the EWK element is able – depending on its configuration – to receive fire alarm signals. Up to 20 EWK devices can be installed in one detection line. Every input can indicate – depending on the specific resistance – one of the following modes:

1. supervision (operation),
2. fault,
3. alarm (technical alarm or fire alarm).

The EWK proper programming consists of a line element declaration (similarly to fire warning devices) and its assignment to a logical number.

The EWK logical number is a figure from the 1 ÷ 50 range, which is assigned to the element in order to enable the EWK input monitoring variant declaration depending on various events in the control panel, and to assign appropriate user messages. Each EWK type element can be assigned only to one logical number and reversely. In programming meaning – with some simplification – it can be stated that for the EWK element a logical number is an equivalent of a zone for fire elements. The EWK element is linked with monitoring variants and the user messages for monitoring inputs just through the logical number.

The EWK-4001 operation way is a resultant of the element programmed operation mode and the input monitoring variant.

The entire EWK-4001 programming process is completed in two stages:

1st stage:

The EWK-4001 declaration consisting in assigning:

- an element number (1 ÷ 64) using the automatic configuration or the configuration with verification or the manual configuration procedures;
- a logical number (1 ÷ 50);
- an operation mode (it is set by default but can be changed - see below).

The EWK-4001 operation mode defines the operation method (standard mode in bold print) for individual 1 - 8 inputs:

- **NO** – shows characteristic resistance closing in order to generate an alarm;
- **NC** – shows characteristic resistance opening in order to generate an alarm.

2nd stage:

The EWK-4001 logical configuration consists in assigning (with a previously defined logical number) the following elements to each input:

- variant (see below);
- fire alarm zone (if required by the variant);
- technical alarm message (if required by the variant).

The EWK-4001 input monitoring variants

Variant 0

Means inactive input (no signals from the input are received).

Variant 1 –technical alarm input

The input activation by specific resistance closing or opening (depending on the input set operation mode) causes technical alarm evoking in the control panel.

Variant 2 – fire alarm input

The input activation by specific resistance closing or opening (depending on the input set operation mode) causes a fire alarm triggering in the control panel assigned zone (if the zone alarming variant criteria requirements are met).

Variant 3 – functioning monitoring

The input activation by specific resistance closing or opening (depending on the input set operation mode) causes a non-maskable fault occurrence in the control panel.

Input monitoring variants are programmed only for an EWK that possesses a logical number.

Note:

After the standard configuration loading and automatic configuration performance, the EWK elements are assigned to a special logical number 0, and after the number attribution, variant 0 is assigned, which causes that such an element is inactive.

Detailed information concerning the EWK element is contained in the EWK-4001 'Installation and Maintenance Manual'.

7.7 SAL-4001 acoustic signalling devices declaration

The SAL-4001 acoustic signalling device is a line element equipped with a piezoelectric transducer which facilitates acoustic signal emission.

The SAL-4001 proper programming consists in a line element declaration (similarly to fire warning devices) and its assignment to a logical number. Afterwards, actuation type and variant should be allotted to this logical number.

The logical number is a figure from the 1 ÷ 50 range, which is assigned to the element in order to enable the SAL actuation variant declaration depending on various events in the control panel.

Each SAL type element can be assigned only to one logical number and reversely. In programming meaning – with some simplification – it can be stated that for the SAL element a logical number is an equivalent of a zone for fire elements. The SAL element is linked with actuation variants just through the logical number. The SAL-4001 operation way is a resultant of the element programmed operation mode and the piezoelectric transducer activation variant.

The entire EWS-4001 programming process is completed in two stages:

1st stage:

The SAL-4001 declaration consisting in assigning:

- an element number (1 ÷ 64) using the automatic configuration or configuration with verification or manual declaration procedures;
- a logical number (1 ÷ 50);
- an operation mode (by default, it is factory set but may be changed - see below).

The operation mode is defined by the following element parameters (standard mode in bold print):

- sound pattern – **type1** or type2 or type3;
- battery power supply monitoring (YES or **NO**);
- internal power supply monitoring (**YES** or NO).

The set of parameters defining an operation mode is directly connected with the line element and is programmed while declaring the SAL element as a line element. An operation mode can be changed in the program at any time.

2nd stage:

The SAL-4001 logical configuration consisting in assigning:

- an output type (TYPE-1 or TYPE-3);
- variant (depending on the output type);
- a set of assigned zones if it is required by a given variant (from the 1 ÷ 256 range).

Output types and variants

Type 1

Table7.3

| Variant | Zone numbers | Time parameters | Actuation criterion |
|---------|--------------|-----------------|---|
| 1 | — | T3 | 1 st stage alarm or activation with the 'ACTIVATED' push button in the 'ALARM DEVICES' field |
| 2 | 0 ÷ 256 | T3 | 1 st stage alarm in assigned zones |

Note:

Time elapsing is interrupted (the T3 time is set at 0 in the countdown time) and the alarm device outputs are immediately activated in case the control panels enters the 2nd stage alarm mode. If the T3 parameter is settled at the maximum level (10 min.), it is possible to obtain 'only from the 2nd stage alarm' actuation criterion.

Type 3

Table 7.4

| Variant | Zone numbers | Time parameters | Actuation criterion |
|---------|--------------|-----------------|--|
| 1 | — | T _{op} | 1 st stage alarm in the control panel |
| 2 | — | T _{op} | 1 st stage alarm in the control panel until acknowledgement |
| 3 | — | T _{op} | 2 nd stage alarm in the control panel |
| 4 | — | T _{op} | 2 nd stage alarm in the control panel until acknowledgement |
| 5 | 0 ÷ 256 | T _{op} | 1 st stage alarm in assigned zones |
| 6 | 0 ÷ 256 | T _{op} | 1 st stage alarm in assigned zones until acknowledgement |
| 7 | 0 ÷ 256 | T _{op} | 2 nd stage alarm in assigned zones |
| 8 | 0 ÷ 256 | T _{op} | 2 nd stage alarm in assigned zones until acknowledgement |

The type and actuation variants are programmed only for a SAL that possesses a logical number. The total assignments of zones to all executive outputs and SAL type elements in the control panel should not exceed 64,000.

Note:

The Top delay time is not applicable (equal to 0).

After the standard configuration loading and the self-declaration performance, the SAL elements are assigned to a special logical number 0, and TYPE 0 is settled, what causes that such an element is inactive.

Detailed information concerning the device is contained in the SAL-4001 element 'Installation and Maintenance Manual'.

7.8 UCS 4000 universal controlling panel declaration

The UCS 4000 universal controlling panel (hereinafter called 'UCS') is a self-dependent apparatus that enables controlling and supervising of fire protection devices, e.g. smoke exhaust dampers, doors, , etc. (detailed information is contained in the device I&MM). The UCS 4000 controller is able to interoperate with the POLON 4200 control panel using a detection line (connected to the circuit as any other line element).

The POLON 4200 control panel receives from the UCS 4000 controller the following modes:

1. quiescent mode (also during the UCS active airing function),
2. fire alarm (active RPO – manual smoke exhaust button connected to the UCS dedicated input or an alarm from a conventional detection line connected to the UCS controller),
3. technical alarm (of the P1 main relay or the P2, P3 additional ones) – output actuation confirmation in the UCS as a result of an fire alarm from the control panel,
4. non-maskable fault (from the P1 main relay or the P2, P3 additional ones) – lack of output actuation in the UCS as a result of an fire alarm from the control panel during certain period of time,
5. testing – the UCS controller during tests of the elements and circuits connected with smoke exhaust process,
6. the UCS fault:
 - the UCS power supply fault:
 - 230 V power supply fault,
 - battery fault,
 - battery charging circuit fault,
 - fault – voltage drop below 22 V,
 - earth fault;
 - the UCS controller fault,
 - microprocessor fault or program memory fault,
 - EEPROM memory fault;
 - the UCS P1 main relay fault:
 - UCS special dedicated inputs and outputs fault,
 - PA alarm relay fault (PSU-4000 module),
 - P2 or P3 individually programmed relay fault (PSU-4000 module),
 - conventional detection line fault (PSU-4000 module),
 - RPO (manual smoke exhaust button) line fault (PSU-4000 module),
 - alarm device output fault (PSU-4000 module),
 - rain/wind sensor power supply (fuse) fault (PSU-4000 module),
 - fault of lack of declaration of the PSU-4000 module.
7. modes of the addressable module provided for communication with the POLON 4000 system:
 - EEPROM memory fault,

- short circuit isolator switching off,
- short circuit isolation,
- lack of communication between the line processor and UCS.

The POLON 4200 control panel – depending on a programmed variant accomplishment – sends to the UCS controlling unit a signal that actuates the P1 main relay (and other inputs individually dependent on this signal). The UCS controlling unit can be programmed using the keys that are located in it, whereas in the POLON 4200 it is necessary to declare the data concerning the UCS controlling unit interoperation with a fire signalling control panel.

The UCS proper programming consists of a line element declaration (similarly to fire warning devices) and its assignment to a logical number.

The UCS logical number is a figure from the 1 ÷ 50 range, which is assigned to the element in order to enable the UCS main relay actuation variant declaration depending on various events in the panel, and to assign appropriate user messages. Each UCS type element can be assigned only to one logical number and reversely.

The UCS 4000 operation way is a resultant of the P1 main relay actuation variant and individual settings of the keys in the UCS controlling unit.

The entire UCS 4000 programming process is completed in two stages.

1st stage:

The UCS 4000 declaration consisting in assigning:

- an element number (1 ÷ 64) using the automatic configuration or configuration with verification or manual configuration procedures;
- a logical number (1 ÷ 50).

2nd stage:

UCS 4000 logical configuration consisting in assigning:

- a P1 main relay actuation variant to a previously assigned logical number;
- fire alarm zone (1 ÷ 256) or zone 0 to block the receipt of a fire alarm from the UCS unit;
- user messages for a technical alarm and non-maskable fault of the outputs: P1 main relay and P2/P3 additional relays.

The P1 main relay actuation variants for the UCS 4000 control panel

See Table 7.5 for the possibilities of the UCS 4000 control panel P1 main relay activation.

For variants with additional zone dependencies: zone number = 0 shows the dependence on a 'union' or 'conjunction' (depending on the variant) of events any zones of a selected control panel.

Table 7.5

| Variant | Zone Number | Actuation criterion |
|---------|-------------|---|
| 0 | — | Inactive output |
| 1 | — | 1 st stage general alarm |
| 2 | 0 ÷ 256 | 'union' of 1 st stage alarms in assigned zones |
| 3 | 0 ÷ 256 | 'conjunction' of 1 st stage alarms in assigned zones |

| | | |
|---|---------|---|
| 4 | — | 2 nd stage general alarm |
| 5 | 0 ÷ 256 | 'union' of 2 nd stage alarms in assigned zones |
| 6 | 0 ÷ 256 | 'conjunction' of 2 nd stage alarms in assigned zones |

Variant 0

Means the lack of the relay actuation criterion (permanently non-activated output).

Variant 1 – general 1st stage alarm

The output activation is performed in the case of a 1st stage alarm occurrences in the control panel.

Variant 2 – 'union' of 1st stage alarms in assigned zones

The output activation is performed in the case of a 1st stage alarm occurrences in at least one zone that is assigned to this relay.

Variant 3 – 'conjunction' of 1st stage alarms in assigned zones

The output activation is performed in the case of 1st stage alarm occurrences in at least two zones that are assigned to this relay.

Variant 4 – general 2nd stage alarm

The output activation is performed in the case of a 2nd stage alarm occurrence in the control panel.

Variant 5 – 'union' of 2nd stage alarms in assigned zones

The output activation is performed in the case of 2nd stage alarm occurrences in at least one zone that is assigned to this relay.

Variant 6 – 'conjunction' of 2nd stage alarms in assigned zones

The output activation is performed in the case of 2nd stage alarm occurrences in at least two zones that are assigned to this relay.

The P1 main relay actuation variants are programmed only for a UCS that possesses a logical number.

In case variant 2 or 5 is used, at least one zone must be assigned to the UCS, however, if variant 3 or 6 is used, at least two zones must be assigned. Variants 1 and 4 do not require assigning any zones.

The total number of zone assignments to all executive outputs and SAL type elements in the control panel must not exceed 64,000.

Note:

- A non-maskable fault is not signalled if variant 0 is set for an output.
- After completing the standard and automatic configuration procedures, the UCS type elements are assigned to a special logical number 0 which makes them inactive.

An exemplary drawing showing the UCS 4000 panel use is included in the UCS 4000 I&MM.

7.9 UCS 6000 universal control panels declaration

The UCS 6000 universal controlling panel (UCS in short) is a self-dependent apparatus that enables controlling and supervising fire protection devices, e.g. smoke exhaust dampers, doors, , etc. (detailed information is contained in the device I&MM). The UCS 6000 controller is able to interoperate with the POLON 4200 control panel through a detection line (connected to the circuit as any other line element).

The POLON 4200 control panel receives from the UCS 6000 controller the following modes:

1. quiescent mode (also during the UCS active airing function),

2. fire alarm (active RPO – manual smoke exhaust button connected to the UCS dedicated input, an alarm from a conventional detection line connected to the UCS controller, or possibly an alarm from an external input),
3. technical alarm – output actuation confirmation in the UCS as a result of a fire alarm from the control panel,
4. non-maskable fault – lack of output actuation in the UCS as a result of a fire alarm from the control panel,
5. the UCS fault.

The UCS 6000 entire configuration is performed using the dedicated software. The configuration procedure is described in the device I&M Manual.

The UCS proper programming in the POLON 4200 control panel consists in a line element declaration (similarly to fire warning devices) and its assignment to a logical number.

The UCS logical number is a figure from the 1 ÷ 50 range, which is assigned to the element in order to enable the UCS individual modules declaration and configuration.

The entire UCS 6000 programming process in the POLON 4200 control panel is completed in two stages:

1st stage:

The UCS 6000 declaration that consists in assignment of:

- element number (1 ÷ 127) using the automatic configuration or configuration with verification, or manual configuration,
- logical number (1 ÷ 50).

2nd stage:

The UCS 6000 logical configuration consisting in:

- MGL modules declaration;
- MPD module declaration;
- MPW modules declaration;
- determination of the zone of fire alarm signalled by the MGS module;
- MGL modules configuration:
 - determination of the zone of fire alarm signalled by the MGS module;
 - determination of the MGL module output activation variant;
 - definition of user messages for a technical alarm and non-maskable fault of the MGL module output;
- MPD module configuration:
 - MPD module PK1 and PK2 outputs activation variants determination;
 - MPD module PK1 and PK2 user messages defining for a technical alarm and non-maskable fault;
- MPW modules configuration:
 - MPW module PK1 and PK2 outputs activation variants determination;
 - MPW module PK1 and PK2 user messages defining for a technical alarm and non-maskable fault;

UCS 6000 panel module outputs activation variants

The UCS 6000 panel module outputs activation variants programming possibilities are presented in Table 7.6.

The 'control panel number' parameter (only for control panels operating in a network) possesses the following meaning:

panel number = 0 means dependence on an event in any control panel belonging to the common supervision area.

panel number > 0 means dependence on an event in a given control panel (provided it belongs to the common supervision area),

panel number "—" enables actuation dependence on evens in a local control panel only. In the case of variants with additional zone dependence, zone number = 0 means dependence on a 'union' of all events from all zones in a given control panel belonging to the common supervision area.

Table 7.6

| Variant | Zone numbers | Actuation criterion |
|---------|--------------|---|
| 0 | — | Inactive output |
| 1 | — | General 1 st stage alarm |
| 2 | 0 ÷ 256 | 'Union' of 1 st stage alarms in assigned zones |
| 3 | 0 ÷ 256 | 'Conjunction' of 1 st stage alarms in assigned zones |
| 4 | — | General 2 nd stage alarm |
| 5 | 0 ÷ 256 | 'Union' of 2 nd stage alarms in assigned zones |
| 6 | 0 ÷ 256 | 'Conjunction' of 2 nd stage alarms in assigned zones |

Variant 0

Means lack of an actuation criterion (permanently non-activated output).

Variant 1 – general 1st stage alarm

The output activation is performed in the case of a 1st stage alarm occurrence in the control panel or any control panels of the common supervision area.

Variant 2 – 'union' of 1st stage alarms in assigned zones of the common supervision area control panels

The output activation is performed in the case of a 1st stage alarm occurrence in at least one zone that is assigned to this relay.

Variant 3 – 'conjunction' of 1st stage alarms in assigned zones of common supervision area control panels

The output activation is performed in the case of a 1st stage alarm occurrence in at least two zones that are assigned to this relay.

Variant 4 – general 2nd stage alarm

The output activation is performed in the case of a 2nd stage alarm occurrence in the control panel or any control panels of the common supervision area.

Variant 5 – 'union' of 2nd stage alarms in assigned zones of the common supervision area control panels

The output activation is performed in the case of a 2nd stage alarm occurrence in at least one zone that is assigned to this relay.

Variant 6 – 'conjunction' of 2nd stage alarms in assigned zones of common supervision area control panels

The output activation is performed in the case of a 2nd stage alarm occurrence in at least two zones that are assigned to this relay.

In the case of variant 2 and variant 5 application, at least one zone should be assigned to an UCS, whereas in the case of variant 3 and variant 6 application, at least two zones should be assigned. Variants 1 and 4 do not require any zone assignation.

In the case of variants with zone dependence, the assigned zones are allocated to own control panel (an alone panel) or to control panels of the common supervision area (panels operating in a network).

The total number of zones assignments to all executive outputs and SAL type elements in the control panel should not exceed 64,000.

Note:

A non-maskable fault is also not signalled if the output is settled at variant 0.

After the standard configuration loading and automatic configuration performance, the UCS elements are assigned to a special logical number 0, which causes that such an element is inactive.

7.10 TSR-4000 terminals declaration

The TSR-4000 terminal is a remote device for the POLON 4000 system control panels' state indication. Up to 16 terminals can be connected to one control panel; transmission is provided utilizing an RS-485 serial interface.

Terminals declaration consists in choosing one of two options: WITH ACCESS or WITHOUT ACCESS in the SYSTEM CONFIGURATION -> HARDWARE DECLARATION -> TERMINALS DECLARATION option. WITH ACCESS means the control panel remote handling permission: an alarm remote acknowledgement or the control panel alarm remote reset is possible.

8 FUNCTIONALITY DESCRIPTIONS

8.1 Alarming

8.1.1 Alarm types

After triggering a line element installed in an addressable detection line, the POLON 4200 control panel – on a basis of decision algorithms – signals PRELIMINARY ALARM, 1st stage alarm or 2nd stage alarm, depending on the alarming variants programmed for particular zones (premises).

PRELIMINARY ALARM is indicated by internal acoustic signalling and a red diode in the field marked ALARM. A message!!! **PRELIMINARY ALARM !!!** appears on the LCD as well as information about the alarming zones number and quantity of zones not mentioned on the display, in a separate box located below (due to limited space). If the alarming zones number exceeds simultaneous display ability (i.e. 8 zones), unrevealed alarms can be read out using the ALARM push button.

The preliminary alarm is indicated internally and it can be acknowledged with the ACKNOWLEDGEMENT push button and afterwards cancelled with the RESET push button.

Note:

The preliminary alarm can be developed into a fire alarm or automatically reset by the control panel in accordance with appropriate algorithms arising from zone alarming variants.

1st STAGE ALARM (fire alarm) is indicated by internal acoustic signalling, a big red FIRE indicator fast flashing and additional red diode in the field marked ALARM.

On the LCD a message **!!! FIRE ALARMS !!!** appears as well as information about the alarming zones number and quantity of zones not mentioned on the display, in a separate box located below (due to limited space). On the right, information about elapsing time is displayed, after which the alarm transmission devices (monitoring) outputs shall be activated. Until this moment the control panel signals the 1st STAGE ALARM.

The 1st stage alarm is indicated internally and it always requires the attending personnel appearance and the alarm acknowledgement by pressing the ACKNOWLEDGEMENT push button within the T1 period) and recognition of a danger in the premises (during T2 period). In the case of lack of appropriate reaction by the personnel on duty to the 1st alarm, the 2nd stage alarm is evoked.

The messages assigned to the alarming zones appear in the main fire alarm box. In case the number of the alarming zones exceeds simultaneous display ability (i.e. 8 zones); unrevealed alarms can be read out using the ALARM push button. All alarming zones can be reviewed except the first one (which is steadily displayed in the first two lines of the alarm box) and the last one (which is displayed in the last two lines).

2nd STAGE ALARM is the control panel internal state (indicated by internal acoustic signalling and the '2ND STAGE ALARM' message in the place of previously displayed monitoring clock), which cases – apart from the control panel signalling – outside transmission of a signal about a fire (actuation of the outputs declared as alarm transmission device outputs – monitoring) and activation of additional outputs, whose activation depends on a 2nd stage alarm occurrence (e.g. external signalling devices or fire protection apparatuses, controlled with the use of relay contacts or potential outputs).

A 2nd stage alarm can be preceded by a 1st stage alarm or is generated immediately depending on an alarm variant programmed for a particular zone in the object or the control panel operation mode. The 2nd stage alarm calls for immediate fire-fighting action. Simultaneously with the optical signalisation during a fire alarm, the control panel evokes a steady acoustic sound, which can be silenced using a backlit 'ACKNOWLEDGEMENT' press button.

Pressing the backlit 'ACKNOWLEDGEMENT' press button results in the fire alarm reset at the control panel. The fire alarm signalling reset is available after obtaining at least the 2nd level access authorisation.

In the POLON 4200 control panel it is possible to choose (to program) one of 17 alarm variants (conventionally marked with 1 ÷ 17 figures) for a particular zone. Triggering an alarm mode by any line element installed in an addressable detection line is verified by the control panel and is called a line element actuation in the further part of this I&MM.

All control panel zones can be subjected to alarming as per 1 ÷ 17 variants as a result of programming according to the PM. Within one zone it is possible to define two detector groups, conventionally named as A and B group. The detector groups enable creating of coincidence within one zone.

An alarm signalling is accompanied by a relevant message printout on the paper tape, if the printer has been appropriately programmed earlier.

8.1.2 One-stage alarm (variant 1)

A fire warning device actuation immediately evokes the 2nd stage alarm. This variant is in particular suitable in the case of zones especially endangered by fire.

8.1.3 Two-stage alarm (variant 2)

A fire warning device actuation evokes the 1st stage alarm signalled acoustically and optically during the T1 period, which is provided for the attending personnel appearance and alarm confirmation (with the ACKNOWLEDGEMENT push button). In the case of lack of appropriate reaction by the personnel on duty, the 2nd stage alarm is evoked. The personnel appearance extends the 1st stage alarm duration time with the T2 time, being measured from the 1st stage alarm acknowledgement, which is provided for the fire danger recognition.

After the T2 period, the 2nd stage alarm is triggered if the personnel does not cancel a fire alarm by obtaining the 2nd access level and pressing the RESET push button. The T1 and T2 times can be programmed in accordance with the PM, taking into consideration the supervised premises individual features.

Two-stage alarming switches to one-stage alarming (immediate 2nd stage alarm) in the case of the control panel 'PERSONNEL ABSENT' or 'DELAYS OFF' operation modes.

8.1.4 One-stage alarm with warning device single reset 40/60 s (variant 3)

After a warning device actuation, the control panel waits for 40 s for actuation of another warning device in the same zone. If it happens, the control panel evokes the 2nd stage alarm. Otherwise, the control panel resets the warning device, treating its actuation as false and awaits further signals from the premises. In case the same warning device is re-actuated or another one is actuated in the same zone within the following 60 s, the control panel evokes the 2nd stage alarm.

Lack of the same or another warning device actuation in the same zone within 60-s period, causes that the control panel recognizes the previous actuation as false.

The variant described above should be applicable in the cases of momentary occurrence of a fire factor not related to a fire.

8.1.5 One-stage alarm with warning device single reset 60 s/8 min (variant 4)

After a warning device actuation, the control panel waits within 60 s actuation of another warning device in the same zone. If it happens, the control panel evokes the 2nd stage alarm. Otherwise, the control panel resets the warning device, treating its actuation as false and awaits further signals from the premises. In case the same warning device is re-actuated or another one is actuated in the same zone within the following 8 minutes, the control panel evokes the 2nd stage alarm.

Lack of the same or another warning device actuation in the same zone within 8-min. period, causes that the control panel recognizes the previous actuation as false.

The variant described above should be applicable in the cases of momentary occurrence of a fire factor not related to a fire.

8.1.6 Two-stage alarm with warning device single reset 40/60 s (variant 5)

After a warning device actuation, the control panel waits within 40 s for actuation of another warning device in the same zone. If it happens, the control panel evokes the 1st stage alarm. Otherwise, the control panel resets the warning device, treating its actuation as false and awaits further signals from the premises. In case the same warning device is re-actuated or another one is actuated in the same zone within the following 60 s, the control panel evokes the 1st stage alarm and the alarming process is continued as in the variant 2. Lack of the same or another warning device actuation in the same zone within 60-s period, causes that the control panel recognizes the previous actuation as false.

The variant described above should be applicable in the cases of momentary occurrence of a fire factor not related to a fire.

8.1.7 Two-stage alarm with warning device single reset 60 s/8 min (variant 6)

After a warning device actuation, the control panel waits within 60 s for actuation of another warning device in the same zone. If it happens, the control panel evokes the 1st stage alarm. Otherwise, the control panel resets the warning device, treating its actuation as false and awaits further signals from the premises. In case the same warning device is re-actuated or another one is actuated in the same zone within the following 8 minutes, the control panel evokes the 1st stage alarm and the alarming process is continued as in the variant 2. Lack of the same or another warning device actuation in the same zone within 8-min period, causes that the control panel recognizes the previous actuation as false.

The variant described above should be applicable in the cases of momentary occurrence of a fire factor not related to a fire.

8.1.8 One-stage alarm with coincidence of two warning devices (variant 7)

After a warning device actuation, the control panel resets the warning device and indicates a preliminary alarm mode. In case the same (reset) warning device is re-actuated and at least one more warning device is actuated in the same zone within the following 8 minutes, the control panel evokes the 2nd stage alarm. Otherwise, after 8 minutes the control panel resets the preliminary alarm mode treating the previous warning device actuation as false, and returns to the quiescent mode.

8.1.9 Two-stage alarm with coincidence of two warning devices (variant 8)

After a warning device actuation, the control panel resets the warning device and indicates a preliminary alarm mode. In case the same (reset) warning device is re-actuated and at least one more warning device is actuated in the same zone within the following 8 minutes, the control panel evokes the 2nd stage alarm and the alarming process is continued as in the variant 2. Otherwise, after 8 minutes the control panel resets the preliminary alarm mode treating the previous warning device actuation as false, and returns to the quiescent mode.

8.1.10 One-stage interactive alarm (variant 9)

In case a detector reveals a fire factor change, it advises other detectors installed in the same zone about this. The change confirmation by other detectors installed in the zone, evokes this zone 2nd stage fire alarm at this control panel.

In many cases a fire can be detected significantly faster in this variant than in the case of waiting for a fire criterion accomplishment by a single detector. Simultaneously, due to proper detectors arrangement and their appropriate type choice for a given zone, the system sensitivity to interference factors is not increased.

Depending on the expected fire types, it is possible to use various combinations of smoke (ionization, optical) and heat detectors. An individual fixed temperature detector actuation in a zone evokes also an alarm in this zone and the 2nd stage fire alarm at this control panel.

Note:

The 4043 model range detectors (DIO-4043, DOR-4043, DUR-4043, and TUN-4043) are unable to operate in a zone programmed in the interactive alarm variant.

8.1.11 Two-stage interactive alarm (variant 10)

In case a detector reveals a fire factor change, it advises other detectors installed in the same zone about this. The change confirmation by other detectors installed in the zone, evokes this zone alarm and the 1st stage fire alarm at this control panel; afterwards, the alarming process is continued as in the variant 2.

In many cases a fire can be detected significantly faster in this variant than in the case of waiting for a fire criterion accomplishment by a single detector. Simultaneously, due to proper detectors arrangement and their appropriate type choice for a given zone, the system sensitivity to interference factors is not increased.

Depending on the expected fire types, it is possible to use various combinations of smoke (ionization, optical) and heat detectors. An individual fixed temperature detector actuation in a zone evokes also an alarm in this zone and the 1st stage fire alarm at this control panel; afterwards, the alarming process is continued as in the variant 2.

Note:

The 4043 model range detectors (DIO-4043, DOR-4043, DUR-4043, and TUN-4043) are unable to operate in a zone programmed in an interactive alarm variant.

8.1.12 One-stage alarm with group-time coincidence (variant 11)

After an actuation of warning devices belonging to one of the A or B group, the warning devices from one group are initially reset and the control panel indicates the preliminary alarm mode. After the preliminary reset, if the warning devices belonging to A and B group (at least one device of each group) are actuated within the following 8 minutes, the control panel evokes the 2nd stage alarm. Otherwise, after 8 minutes the control panel resets the preliminary alarm mode treating the previous warning device actuation as false, and returns to the quiescent mode.

Note:

The variant proper performance requires declaring at least one warning device to A and B group (2 warning devices for each group are recommended). The groups created in this way should not be

separated with any physical obstacle. Any failure to meet those conditions can result in the alarming warning device continual reset.

8.1.13 Two-stage alarm with group-time coincidence (variant 12)

After an actuation of warning devices belonging to one of the A or B group, the warning devices from one group are initially reset the control panel indicates the preliminary alarm mode. After the preliminary reset, if the warning devices belonging to A and B group (at least one device of each group) are actuated within the following 8 minutes, the control panel evokes the 1st stage alarm and the alarming process is continued as in the variant 2. Otherwise, after 8 minutes the control panel resets the preliminary alarm mode treating the previous warning device actuation as false, and returns to the quiescent mode.

Note:

The variant proper performance requires declaring at least one warning device to A and B group (2 warning devices for each group are recommended). The groups created in this way should not be separated with any physical obstacle. Any failure to meet those conditions can result in the alarming warning device continual reset.

8.1.14 Two-stage alarm with group coincidence in order to speed up 2nd stage alarm (variant 13)

After an actuation of warning devices belonging to one of the A or B group, the control panel evokes the 1st stage alarm and the alarming process is continued as in the variant 2.

Actuations of warning devices of both (A and B) groups simultaneously (coincidence) results in the 2nd stage alarm immediate triggering.

Note:

The variant proper performance requires declaring at least one warning device to A and B group (2 warning devices for each group are recommended). The groups created in this way should not be separated with any physical obstacle.

8.1.15 Two-stage alarm with preliminary zone reset and group coincidence in order to speed up 2nd stage alarm (variant 14)

After an actuation of a warning device belonging to the zone, the control panel measures out a 40-s period and automatically resets the zone then.

If any warning device is actuated again within 8 minutes from the zone reset, the control panel evokes the 1st stage alarm and the alarming process is continued as in the variant 2. Otherwise, in the case of a renewed fire warning device actuation outage in the zone within 8 minutes, the control panel treats the previous warning device activation as false, and returns to the quiescent mode.

Actuations of warning devices of both (A and B) groups simultaneously (coincidence) results in the 2nd stage alarm immediate triggering.

Note:

The variant proper performance requires declaring at least one warning device to A and B group (2 warning devices for each group are recommended). The groups created in this way should not be separated with any physical obstacle.

8.1.16 Two-stage alarm with two-detector coincidence in order to speed up 2nd stage alarm (variant 15)

After an actuation of a warning device belonging to the zone, the control panel evokes the 1st stage alarm and the alarming process is continued as in the variant 2.

An actuation of two or more warning devices in the zone results in the 2nd stage alarm triggering acceleration.

Note:

The variant proper performance requires declaring at least two warning devices (more is recommended) in the zone.

8.1.17 Two-stage alarm with preliminary zone reset and two warning devices coincidence in order to speed up 2nd stage alarm (variant 16)

After an actuation of a warning device belonging to the zone, the control panel measures out a 40-s period and automatically resets the zone then.

If any warning device is actuated again within 8 minutes from the zone reset, the control panel evokes the 1st stage alarm and the alarming process is continued as in the variant 2. Otherwise, in the case of a renewed fire warning device actuation outage in the zone within 8 minutes, the control panel treats the previous warning device actuation as false, and returns to the quiescent mode.

An actuation of two or more warning devices in the zone results in the 2nd stage alarm accelerated triggering.

Note:

The variant proper performance requires declaring at least two warning devices (more is recommended) in the zone.

8.1.18 One-stage alarm with temporal zone disconnection (variant 17)

A fire warning device actuation during the control panel operation in the PERSONNEL ABSENT mode (the PERSONNEL ABSENT indicator is lit) evokes the 2nd stage alarm. During the control panel operation in the PERSONNEL ABSENT mode (the PERSONNEL ABSENT indicator is lit), the zone is automatically disabled (the control panel cannot 'see' warning devices).

8.1.19 ROP manual call point alarming

After the ROP-4001, ROP-4001H manual call points actuation, the control panel evokes the 2nd stage alarm immediately regardless of the alarm variant being programmed for the zone, which the call points are assigned to.

8.1.20 Alarming in 'DELAYS OFF' mode

In the 'DELAYS OFF' mode, the control panel enters no output activation delays. The T1, T2 and T3 times are set at 0, what results in two-stage alarms replacement with appropriate one-stage alarms. However, the delays outage does not mean cancellation of coincidental alarm variants and those with preliminary reset (in those variants two-stage alarms are replaced by one-stage alarms).

The 'DELAYS OFF' mode means that the delays of outputs for PK relays and LS potential output are set at 0.

Note:

The 'DELAYS OFF' mode does not cancel the delays being programmed directly in the EKS-4001 element with the use of 'OPERATION MODE' option.

8.1.21 Alarming in 'PERSONNEL ABSENT' mode

The alarm variants that are intended for false alarm elimination, require the attending personnel co-operation. Those variants are useless in the case of the personnel absence at the control panel. Then any delay in a fire reporting to the appropriate service is inadvisable. To achieve this, it is possible to switch the control panel to the PERSONNEL ABSENT operation mode what causes that the alarm variants of all zone are automatically changed for one-stage alarms (variant 1) or – in the case of interactive variants – for one-stage interactive alarms (variant 9.)

The operation mode switchover is performed after the PERSONNEL ABSENT push button pressing and is indicated by illumination of the diode located in the button. The control panel operation mode change is available from at least the 2nd access level.

The PERSONNEL ABSENT operation mode switchover is executed automatically if one of four times that automatically changes the operation mode for the PERSONNEL ABSENT, is programmed. The operation mode change for the PERSONNEL ABSENT is carried out by pressing the PERSONNEL ABSENT push button again and is indicated by switching off the diode located in the button. Then, all zones are recovered with the alarm variants being programmed earlier.

8.2 Fault signalling

The POLON 4200 control panel – due to internal self-monitoring circuits – reveals and indicates faults that occur in the detection lines and inside the panel, too. The revealed faults are indicated optically and acoustically. Faults are indicated optically by steady yellow light of the FAULT collective diode and additionally they are indicated acoustically with a slow interrupted sound of a steady frequency.

The FAULT optical and acoustic indication is reset automatically after the fault removal. The FAULT acoustic indication is switched off after pressing the ACKNOWLEDGEMENT backlit push button.

Information about the revealed faults is automatically displayed on the LCD. In case any new fault does not occur within 10 minutes from the latest fault registered, the LCD is switch off. Then, it is possible to review the faults revealed recently, using the FAULT push button. Messages about recently revealed faults appear on the LCD after the FAULT push button repeated pressing. If the messages number exceeds the display capacity, they can be 'scrolled' with the help of the same push button or ↑↓ buttons.

An exception of the above rule is a non-maskable fault occurring in the monitoring circuits (properly programmed) of the LK monitoring lines or EKS-4001 monitoring and controlling elements, whose messages appear automatically on the display and are shown until their removal.

A relevant message printout on the paper tape about a fault occurrence is carried out after the fault detection, if the printer has been appropriately programmed earlier.

8.2.1 Faults type

a) System faults:

- faults of the program memory, RAM operation memory or SETUP configuration,
- the micro-processor operation interference.

b) Micro-processor based modules faults:

- the LCD display and operator's console micro-processor controller fault,
- the MSL-1M-42 module micro-processor controller fault,
- communication loss with the LCD controller and operator's console,
- communication loss with the MSL-1M-42 module controller,
- lack of declaration of the MSL-1M-42 module, in case of its connection.

c) Detection lines faults:

- line processor fault,
- line output short circuit,
- loop output short circuit,
- break in a detection line,
- detection line earth fault,
- number of line elements in a detection loop-shaped line higher than 64,
- non-declared elements in a detection line,
- improper detection line parameters (resistance, capacity),
- lack of line element response to a control panel enquiry,
- multiple declaration of the same line element.

d) line elements faults:

- measuring element fault,

- switched on short circuit isolator,
 - EEPROM memory fault,
 - EKS input line fault,
 - EKS WE1 input line fault,
 - EKS WE2 input line fault,
 - EKS WE1 non-maskable fault,
 - EKS WE2 non-maskable fault,
 - EWS relay fault,
 - SAL battery or external power supply unit fault.
- e) control panel inputs and outputs fault:
- PK supervised relay output fault
 - LS potential supervised output fault,
 - LK monitoring line input non-maskable fault.
- f) power supply faults:
- basic power supply source voltage outage,
 - reserve power supply source fault (battery lack, short circuit of battery connection contacts or the BZ1 fuse burnout),
 - battery voltage drop below $22\text{ V} \pm 1\text{ V}$,
 - battery cluster charging device fault,
 - burnout or lack of the BZ3 melt fuse insert in the MZ-4212 module,
 - earth fault, i.e. power supply module output circuit connection with the control panel case or grounding.
- h) TSR 4000 terminal fault
- configuration setup memory fault,
 - EPROM memory fault,
 - LCD display fault,
 - relay output fault,
 - signalling line fault,
 - improper terminal number,
 - 230 V power supply fault,
 - battery fault,
 - battery charging circuit fault,
 - voltage drop below 22 V,
 - terminal earth fault.
- i) other faults:
- thermal printer fault,
 - lack of paper roll in printer.

Note:

In order to reset a system fault it is necessary to switch the K6 key of SW1 switch located on PSC board and then perform the active processor reset. After the system fault reset, it is required to load the standard configuration and to configure the control panel again.

8.3 Testing

The POLON 4200 control panel enables execution of three types of tests to recognise efficiency of:

1. TSO-4200 table signalling elements,
2. line elements installed in the premises,
3. executive devices being controlled by the EKS-4001, EWS-4001, SAL-4001 controlling elements.

Test execution is allowable after obtaining a permission from the operator from at least the 2nd access level. The tests should be carried out in accordance with PM.

8.3.1 TSO-4200 table signalling elements testing

During signalling elements test execution, consecutive optical diodes are lit and acoustic signals are switched on. After the test, the control panel automatically returns to normal operation.

A testing process is automatically interrupted in the case of a fire alarm signal receipt by the control panel, it is impossible to switch to the test mode during a fire alarm signalling. Any element testing process can be interrupted with ESC key.

8.3.2 Testing of line fire elements in a zone

The POLON 4200 control panel enables performing tests of addressable line elements belonging to any zone.

The elements switchover for testing in the zone is carried out in accordance with the PM. The zone switchover for testing is signalled by steady light of the yellow collective TESTING diode.

After a test alarm signal receipt from a line element, information about the test alarm is displayed on the LCD. The alarming element reset takes place after ca. 60 s.

The elements (detectors) testing in a zone is switched off according to the PM. Then the yellow collective TESTING diode is turned off (if no other elements are tested).

A fire alarm from a zone which is not switched over for testing, it causes that the testing process is automatically terminated and the control panel starts fire alarm signalling pursuantly to the variant programmed.

Within the tested zone any quantity of line elements can be simultaneously in an alarm mode, it is recommended, however, to activate the line elements consecutively in order to inspect them properly.

Switching for TESTING is impossible during a fire alarm signalling and in the case of damaged or switched off zones.

8.3.3 EKS-4001 monitoring and controlling elements testing

The EKS-4001 element testing means that the device is switched over to the testing mode, what should result in the output relay activation. In response to that, the element should indicate an appropriate relay output state.

8.3.4 EWS-4001 controlling elements testing

The EWS-4001 element testing means that the element respective relay outputs are switched over to the testing mode, what should activate the relay being tested. In response to that, the element should indicate an appropriate state of the relay output being tested.

8.3.5 EWK-4001 monitoring elements testing

The EWK-4001 element testing consists in imposing the specific technical alarm state in respective inputs using a resistor. The control panel should indicate the technical alarm state of those inputs.

8.3.6 SAL-4001 acoustic signalling devices testing

The SAL-4001 device testing consists in switching the element over to the testing mode, what should activate acoustic signalling

8.3.7 Line elements location inspection

The POLON 4200 control panel enables checking a line element location through evoking alternate illumination of yellow and red diode of the element. The testing procedure is described in the PM.

8.4 System elements disablement/re-enablement

The control panel software enables disablement of line elements, zones, outputs controlled by the PPW module or EKS-4001 monitoring and controlling elements.

Any disablement is indicated by the control panel with a steady light of the DISABLEMENT collective yellow diode. Disablement and re-enablement is executed from at least 2nd access level.

8.4.1 Fire warning devices and zones disablement/re-enablement

In the case of fire warning devices fault or performing repair works in the supervised premises that can produce false alarm triggering, the control panel provides possibility to switch off monitoring of the premises section through the entire zone (or its appropriate part) disablement.

Fire warning devices disablement/re-enablement is carried out in the FIRE WARNING DEVICES DISABLEMENT option.

A section of a zone disablement/re-enablement is performed disabling individual addressable elements in the zone, whereas the whole zone disablement/re-enablement can be performed in much simpler way, carrying out the operation for the whole zone in the ZONES DISABLEMENT option.

Any disablement of fire warning device or entire zone entails that the control panel does not receive alarm and fault signals from the disabled line elements, therefore automatically switches off fault signalling within this zone, if such signal is sent. After the zone re-enablement, if the fault is not removed, the fault signalling occurs again.

Note:

A partial zone disablement, with programmed alarm variant higher than the second one, causes that this zone variant is automatically replaced with the immediate one (variant 1). After the zone complete re-enablement, the initially programmed variant recurs.

8.4.2 PK relays disablement/re-enablement

The PK relays disablement/re-enablement is accomplished in the RELAYS DISABLEMENT option. The PK relay disablement brings switching an appropriate relay off regardless of the control panel state.

8.4.3 LS signalling line disablement/re-enablement

The LS signalling line disablement/re-enablement is achieved in the SIGNALLING LINE DISABLEMENT option as a logical device. The LS line disablement results in a fault signalling interruption. After a re-enablement, unless the fault is removed, signalling is restored.

8.4.4 LK monitoring lines disablement/re-enablement

The LK monitoring lines disablement/re-enablement is executed in the MONITORING LINES DISABLEMENT option as a logical device. The LK line disablement results in an interruption of fault signalling or technical alarm signalling. After a re-enablement, unless the fault or technical alarm is removed, signalling appears again.

8.4.5 EKS-4001 monitoring and controlling elements disablement/re-enablement

The EKS-4001 monitoring and controlling elements disablement/re-enablement is accomplished in the EKS ELEMENTS DISABLEMENT option as logical devices. The EKS disablement produces switching the output relay off and an interruption of the element fault signalling or technical alarm signalling. After a re-enablement, unless the fault or technical alarm is removed, signalling is restored.

8.4.6 EWS-4001 controlling elements disablement/re-enablement

The EWS-4001 controlling elements disablement/re-enablement is achieved in the EWS ELEMENTS DISABLEMENT option as logical devices. The EWS disablement results in switching the output relay

off and an interruption of the output fault signalling. After a re-enablement, unless the fault is removed, signalling is restored. After a re-enablement, unless the fault is removed, signalling is restored.

8.4.7 EWK-4001 monitoring elements disablement/re-enablement

The EWK-4001 monitoring elements disablement/re-enablement is executed in the EWK ELEMENT DISABLEMENT option as a logical device. The EWK disablement results in switching the output off, what induces that no signal from this output are received, and the fault or technical alarm signalling is interrupted. After a re-enablement, the control panel indicate the current state of this output.

8.4.8 SAL-4001 acoustic signalling devices disablement/re-enablement

The SAL-4001 acoustic signalling disablement/re-enablement is executed in the SAL ELEMENT DISABLEMENT option as a logical device. The SAL disablement results in switching off the SAL signalling and an interruption of the fault alarm signalling. After a re-enablement, unless the fault is removed, the fault signalling is restored.

8.5 Event memory and alarm memory

8.5.1 Event memory

The POLON 4200 control panel is able to store up to 2,000 latest events in its non-volatile memory. Every event is characterized with a detailed text description and date and time of event (with 1-s accuracy). In the event memory, among others, the following events are saved in chronological order:

1. alarm events,
2. technical alarms,
3. faults,
4. testing,
5. disablements,
6. executive devices activations,
7. attending personnel reaction of the following nature; acknowledgements, resets, delays switching on, etc.

The event memory contents can be reviewed on the display or printed out with a printer (the event memory operation description is included in the PM).

Note:

The standard configuration loading erases the event memory.

8.5.2 Alarm memory

The control panel is able to store up to 9,999 latest alarms in its non-volatile memory with information about the date and time (with 1-s accuracy) of an alarm occurrence as well as its location (zone).

The alarm memory contents can be reviewed on the display or printed out with a serial printer (the event memory operation description is included in the PM).

Note:

The alarm memory can be erased only from the control panel Menu after obtaining the 4th access level. The standard configuration loading does not erase the alarm memory.

9 STANDARD CONFIGURATION

The POLON 4200 control panel is delivered to the user with initial operation conditions programmed by the manufacturer, what is called the standard (default) configuration.

Pursuantly to the standard configuration, the control panel is programmed as follows:

1. the MSL-1M-42 module is declared,
2. every addressable element (in the addressable area) is declared as type 0 (those elements are not reviewed by the control panel),
3. addressable elements are possibly assigned to the zones of the numbers that are consistent with the numbers of lines where they are installed; with A group being programmed,
4. lack of configuration of controlling, monitoring and signalling elements (EKS-4001, EWS-4001, SAL-4001); line elements not assigned, zones are not allotted (empty zone matrix), no variants are set,
5. all user messages are assigned to the logical numbers of EKS-4001, EWK-4001 – of standard type,
6. variant 2 (two-stage alarming) is assigned to all zones,
7. all user messages assigned to zones – of standard type,
8. the PK1 relay (marked as PU) steadily programmed as a general fault signalling output,
9. the PK2 output relay programmed as TYPE3 variant 1, with no delays (actuation in the case of the 1st stage alarm at the control panel),
10. the PK3 output relay programmed as TYPE2 (monitoring output),
11. the remaining PK4-PK8 relays and LS1-LS2 signalling lines programmed as TYPE 0 (inactive),
12. PK relays and LS signalling lines possibly without zone coincidence (zone matrices empty),
13. all LK monitoring lines programmed in variant 0 (inactive),
14. all user messages assigned to monitoring lines – of standard type,
15. the DR-48 printer – not declared,
16. T1 time (for acknowledgement) – set at 30 s,
17. T2 time (for danger recognition) – set at 1 min,
18. T3 time (acoustic signalling delay) – set at 0,
19. time of automatic operation mode switchover PERSONNEL PRESENT/PERSONNEL ABSENT – not being programmed,
20. factory access level at the 2nd level - 2222,
21. factory access level at the 3rd level - 3333,
22. factory access level at the 4th level - 3112,
23. event memory – erased,
24. review register – erased, review monitoring function – inactive.

9.1 User configuration programming

In order to adjust the control panel to its operation conditions predicted in the circuit design, it is necessary to program the panel individually. The programming process should be carried out in accordance with the PM from the 3rd or 4th access level. The entered configuration data shall be saved also in the case of the control panel complete power supply outage.

Note:

After the control panel programming, it is recommended to send the configuration to a computer (utilising the configuration software) and prepare the data backup.

9.2 Standard configuration/access codes loading

It is possible that the user loads the control panel standard settings. The standard configuration loading operation should be performed exclusively in case an old configuration must be deleted (memory erasing) and a new one must be created from the beginning.

The standard configuration loading can be completed by restarting the μ PC micro-processor in the PSC-43 module, if the K1 key of the SW1 switch is turned on.

The factory access codes loading can be completed by restarting the μ PC micro-processor in the PSC-43 module, if the K1 key of the SW1 switch is turned on.

Note:

The standard configuration loading can last ca. 2 minutes.

10 ACCESS CODES

The POLON 4200 control panel is intended to be handled by 4 groups of people of various qualifications. The range of possible operations is divided into 4 levels as per Table 11.1.

Access to particular levels (with an exception of the 1st level) can be obtained by entering an access code. The access code is represented by a figure consisted of 4 to 8 digits.

The 2nd and 3rd level access codes can be program changed by the servicing personnel after obtaining the 3rd level access.

Table 11.1

| Access level | Operator access | Allowable operations |
|---|-----------------------------------|--|
| 1 st (1) | no code necessary | Alarm or fault ACKNOWLEDGEMENT, acoustic signalling silencing, readout of fire alarms, technical alarms, faults, disablements and zone testing |
| 2 nd (2) | 2 nd level access code | As per 1 st level plus alarm RESET, PERSONNEL PRESENT/PERSONNEL ABSENT switchover, disablement, switching over to testing |
| 3 rd (3) | 3 rd level access code | As per 2 nd level plus control panel configuration except modules and interface output declaration |
| 4 th (4) | 4 th level access code | As per 3 rd level plus hardware configuration change |
| ⁽¹⁾ – for the control panel direct servicing personnel ⁽²⁾ – for the direct servicing personnel or the maintenance technician ⁽³⁾ – for a person being authorised for program configuration change ⁽⁴⁾ – for the manufacturer and authorised servicing company for hardware configuration change | | |

11 INSTALLATION

11.1 Control panels installation location

The POLON 4200 control panel should be installed in the premises where 24-hour duty is provided. In the case of lack of such 24-hour attendance, it is obligatory to ensure that the control panel signals are passed to a place where 24-hour personnel on duty is present, using the monitoring system or additional signalling relay contacts.

The control panel should be placed in a visible accessible place, which is not exposed to direct sunlight, far from heat sources.

Ambient temperature should not be lower than 0 °C and higher than + 40 °C. In the case of high noise level, outdoor acoustic signalling devices should be applicable, controlled by signalling line or the PPW module relay contacts.

The control panel should be fixed to a wall using a special frame delivered with the device (Fig. 11.1). In the control panel vicinity (within sight) a manual fire call point should be installed.

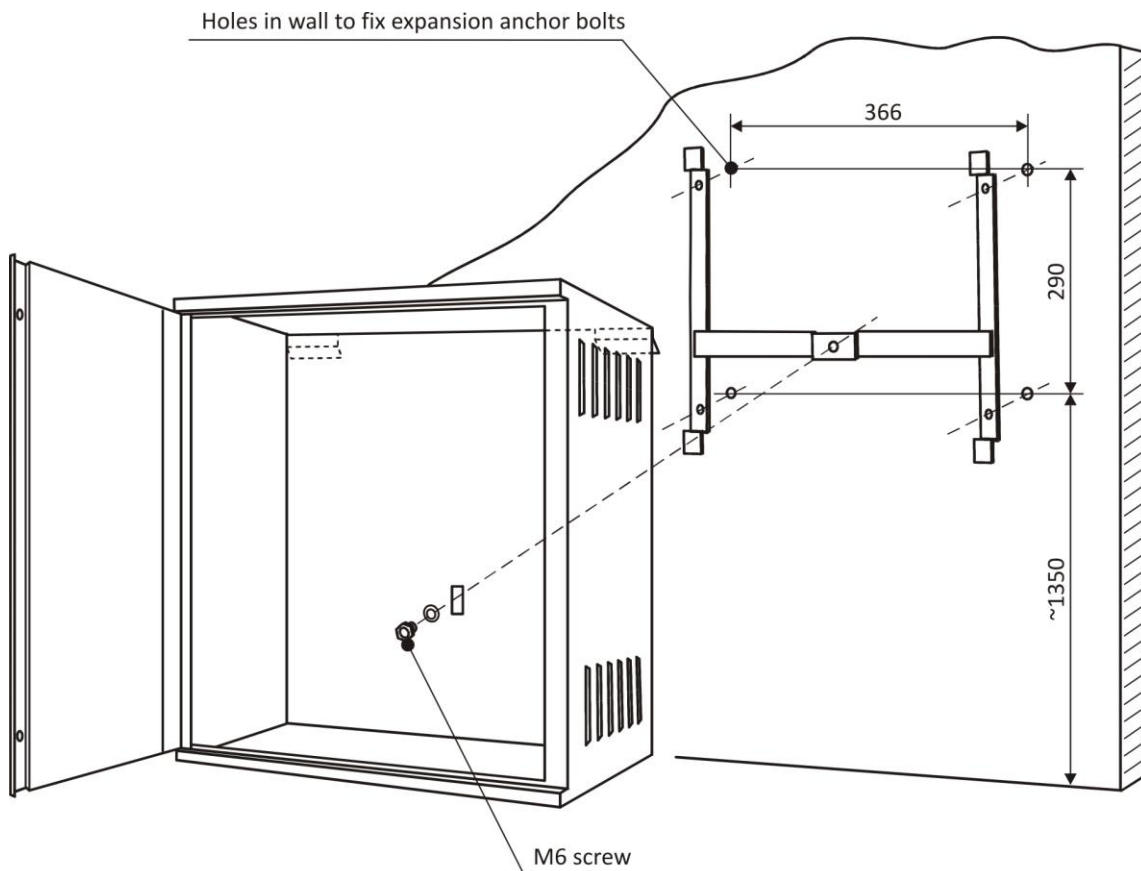

Fig. 11.1 Control panel wall mounting

11.2 Power supply connection

Three clamps (located in the MZ-4212 module board) are provided to connect mains cables that supply the control panel. The mains clamps are covered with a special isolation shield with ~230 V/50 Hz description. The supplying cable marking is provided on appropriate clamps. The PE protective cable should be connected directly to the collective grounding clamp located near to the MZ-4212 module on the control panel casing, and then to the module PE clamp. The reserve power supply (batteries) should be connected after the mains power supply connection.

11.3 Line elements installation

Detection line wires and external signalling circuits wires are introduced to the control panel through a round opening placed in the top or back side of the panel.

Before wire connection, it is necessary to examine thoroughly particular circuits routing to the control panel output switch clamps. Special attention should be given to detection lines and loops wires polarization.

Before detection lines wires connection it is necessary to ensure whether the wires resistance and capacity, and insulation resistance do not exceed allowable values.

Addressable detection lines elements connection way is illustrated in Fig. 11.2 and Fig. 11.3.

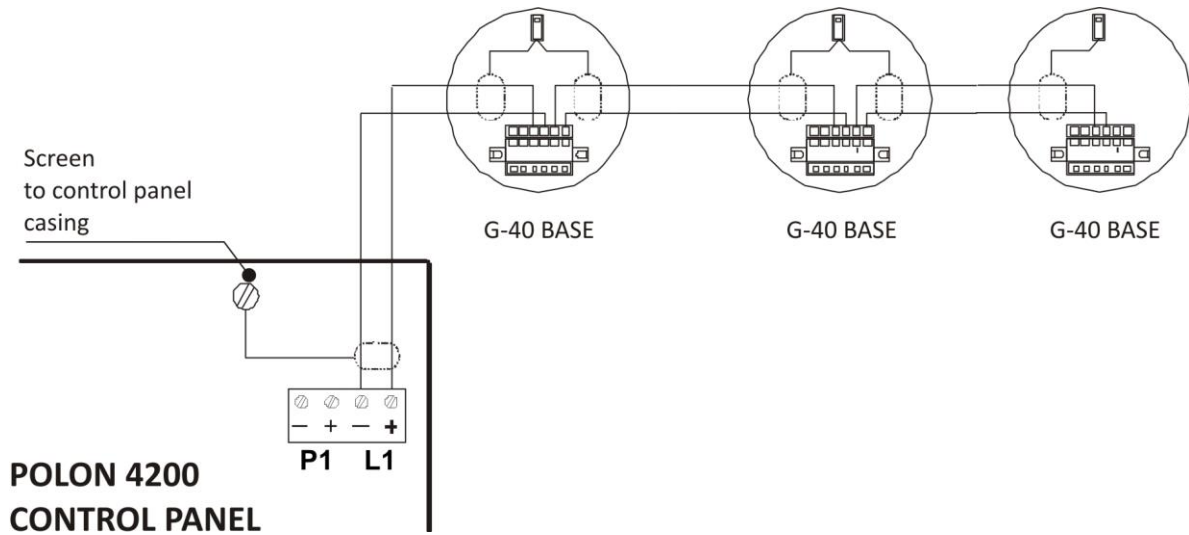

Fig. 11.2 Type B radial line elements connection way

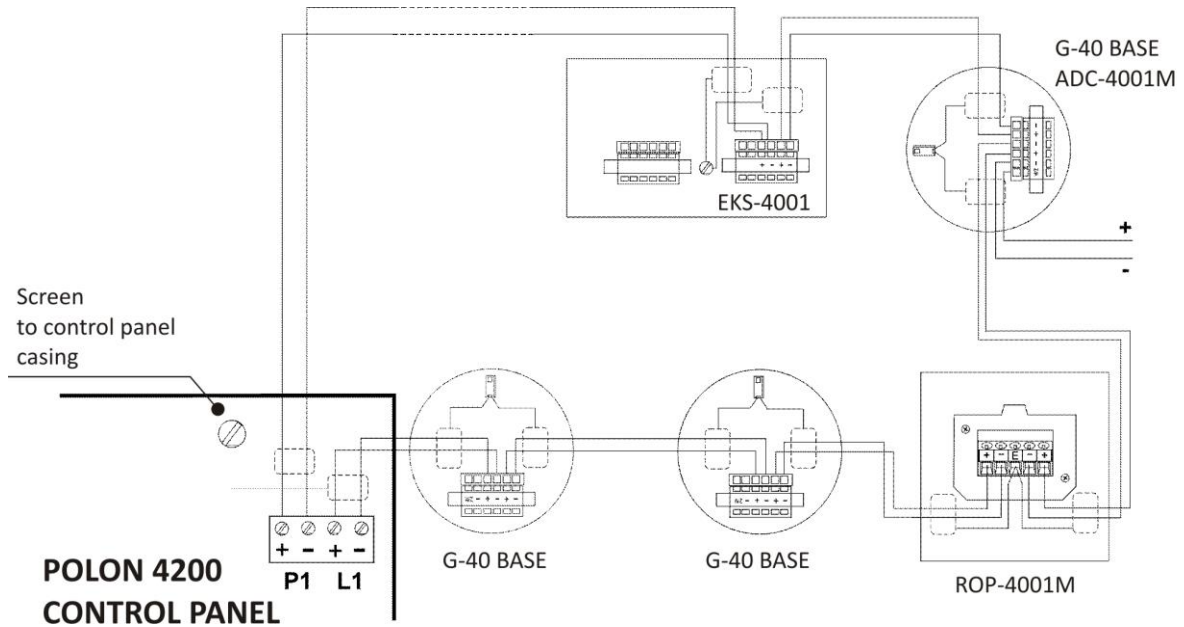

Fig. 11.3 Type A loop-shaped line elements connection way

11.4 Control panel inputs and outputs

| Terminal block | Contacts marking | Location | Description |
|----------------|------------------|-----------|------------------------------|
| ZL1 | - + P1 | MSL-1M-42 | Detection loop 1 return |
| ZL2 | - + L1 | „ | Detection line/loop 1 output |
| ZL3 | - + P2 | „ | Detection loop 2 return |
| ZL4 | - + L2 | „ | Detection line/loop 2 output |
| ZL5 | - + P3 | „ | Detection loop 3 return |
| ZL6 | - + L3 | „ | Detection line/loop 3 output |

| | | | |
|------------------|------------------|---------|--|
| ZL7 | - + P4 | „ | Detection loop 4 return |
| ZL8 | - + L4 | „ | Detection line/loop 4 output |
| LS1 | 1 + - | „ | Signalling line output (of 0.5 A load in alarm) |
| LS2 | 2 + - | „ | Signalling line output (of 0.1 A load in alarm) |
| LK1 | 1 + - | „ | Monitoring line No. 1 input |
| LK2 | 2 + - | „ | Monitoring line No. 2 input |
| PU | 1 C-NC-NO | PPW-42 | Fault signalling PK1 relay output, in quiescent mode closed C-NO |
| PK2 | 2 C-NC-NO | „ | Relay No. 2 programmable outputs |
| PK3 | 3 C-NC-NO | „ | Relay No. 3 programmable outputs |
| PK4 | 4 C-NC-NO | „ | Relay No. 4 programmable outputs |
| PK5 | 5 C-NC-NO | „ | Relay No. 5 programmable outputs |
| PK6 | 6 C-NC-NO | „ | Relay No. 6 programmable outputs |
| PK7 | 7 C-NC-NO | „ | Relay No. 7 programmable outputs |
| PK8 | 8 C-NC-NO | „ | Relay No. 8 programmable outputs |
| | A B CHGND | “ | Output to TSR-4000 terminal |
| ZK1 | | „ | External keyboard connector |
| ZP1 | | „ | RS 232 port output to (acc. to declaration) PC computer or digital monitoring |
| External devices | + - Z5 + - Z6 | MZ-4212 | External devices power supply output of maximum total load: 0.1 A/24 V in quiescent mode, 0.6 A/24 V in alarm mode |

12 OPERATION AND MAINTENANCE

12.1 Proper operation rules

The control panel unfailling operation depends on maintaining appropriate operating conditions, power supply voltage, battery condition and periodical inspections performance.

The periodical inspections should be carried out by an Authorised Service Station that was appointed by the user to perform maintenance works. Any damage should be immediately reported to the service station. In the case of fuse replacement, attention should be paid to their nominal values. It is not allowed to replace a burnt fuse with a spare fuse with a greater nominal value, since it can result in the unit damage.

The following fuses are used in the POLON 4200 control panel installations:

- In the power supply module:

| | |
|--------------------------------|---|
| BZ1/3.15 A of F3,15L250 V type | battery cluster circuit protection, |
| BZ2/1 A of F1250 V type | +24 V control panel power supply circuit protection |
| BZ3/1 A of F1250 V type | +24 V auxiliary external device power supply circuit protection |

- In the MSL-1M-42 module:

| | |
|-------------------------|-----------------------------|
| B1/500 mA of F500L250 V | MSL-1M-42 module protection |
|-------------------------|-----------------------------|

- In the PPW-42 module:

| | |
|-------------------------|--------------------------------|
| B1/500 mA of F630L250 V | LS signalling line protection, |
|-------------------------|--------------------------------|

12.2 Periodic inspections and maintenance rules

The POLON 4200 control panel periodical inspections, according to the point 11.2 of the PKN-CEN/TS 54-14:2006 standard, should be carried out at least once per year.

Every 6 months it is recommended to check connections between the control panel case and the shielding, grounding and zeroing cable and to clean battery clamps.

The battery charging level should be checked at least once a year. For this purpose, it is necessary to disconnect the mains power supply with the AC power supply switch for approx. 2 hours and, after the system renewed activation, to check if, within a period not longer than 5 hours, the mains power supply device recharges the battery panel and automatically switches to the buffering mode.

A properly operating and regularly inspected control panel does not require any special maintenance works. It is recommended to regularly remove dust from the control panel outer surfaces.

The POLON 4200 control panel enables writing into its configuration a time parameter (expressed in months), stipulating required frequency of the system inspections and maintenance works. If the function is activated and, in case a new inspection is not confirmed (by entering into reviews register) despite the allowable time from the latest inspection has elapsed, the control panel signals on the liquid crystal display the necessity to perform new review (with 30-second interval).

The review register enables saving of up to 255 entries (without possibility of the previous entries modification). The register deleting is possible only through the standard configuration loading.

13 PACKING, TRANSPORTATION, STORAGE

13.1 Packing

The control panel, wrapped with a foil bag, is packed in a transport box made of five-layer cardboard. Apart from it, the following items are packed into the transport box:

1. frame for control panel mounting and fixing elements,
2. modules in unit packages,
3. spare parts,
4. technical documentation
5. warranty card.

13.2 Transport rules

The control panel in the factory packing should be carried in closed spaces of standard means of land transport taking into account the transport guidelines stated on the package and protecting it against sudden vibrations and ambient temperatures lower than - 25 °C and higher than + 55 °C.

13.3 Storage rules

The control panel should be stored in closed spaces of ambient temperature from + 5 °C to + 40 °C and relative humidity between 40 % and 70 %, free of caustic vapours and gases. During storage, the device should not be exposed to direct sunlight or heating elements influence.

14 DESIGNER'S TABLES

Table 15.1 MSL-1M-42 MODULE DECLARATION

| | |
|------------------------------------|--|
| MSL- 1M- 42 module | LINE NO. 1 : LINE NO. 2 : LINE NO. 3 : LINE NO. 4 : |
|------------------------------------|--|

Table 15.2 SERIAL PORTS DECLARATION

| | <i>PORT TYPE</i> | <i>TRANSMISSION SPEED</i> |
|------------|------------------|---------------------------|
| PORT No. 1 | | |
| PORT No. 2 | | |

Table 15.3 ALARMING DELAY TIMES

| | |
|---------|--|
| T1 time | |
| T2 time | |
| T3 time | |

Table 15.4 PERSONNEL ABSENT MODE CHANGE TIMES

| <i>PERSONNEL ABSENT mode change time</i> | |
|--|--|
| PN1 time | |
| PN2 time | |
| PN3 time | |
| PN4 time | |

APPENDIX A – POLON 4000 SYSTEM LINE ELEMENTS

| Element description | | Quiescent current ¹⁾ |
|-----------------------|--|---------------------------------|
| DIO-4043 | addressable ionisation smoke detector | 150 µA |
| DIO-4046 | “ | |
| DOR-4043 | addressable optical smoke detector | 150 µA |
| DOR-4046 | “ | |
| DUR-4043 | addressable universal optical smoke detector | 150 µA |
| DUR-4046 | “ | |
| TUN-4043 | addressable universal heat detector | 120 µA |
| TUN-4046 | “ | |
| DOT-4046 | addressable multi-sensor smoke and heat detector | 150 µA |
| DPR-4046 | addressable multi-sensor smoke detector | 170 µA |
| DUT-6046 | addressable multi-sensor smoke and heat detector | 150 µA |
| DOP-6001 | optical line smoke detector | 300 µA |
| DUR-4047 | optical smoke radio detector | - |
| ROP-4001M, ROP-4001MH | manual fire call points | 135 µA |
| ADC-4001M | adapter (burdened with a side line): | |
| | - programmed in operation mode 1 | 6.8 mA |
| | - programmed in operation mode 2 | 16.0 mA |
| | - programmed in operation mode 3 | 2.5 mA |
| | - programmed in operation mode 4 | 0.5 mA |
| | - programmed in operation mode 5 | 2.2 mA |
| | - programmed in operation mode 6 | 1.33 mA |
| ACR-4001 | radio detectors adapter | 6.0 mA |
| EKS-4001 | monitoring and controlling element | 145 µA |
| EWS-4001 | multi-output controlling element | 400 µA |
| EWK-4001 | multi-input monitoring element | 150 µA |
| SAL-4001 | addressable acoustic signalling device: | |
| | - power supplied from battery or ext. source | 150 µA |
| | - power supplied only from line ²⁾ | 600 µA |
| UCS 4000 | universal fire controlling unit | 600 µA |
| UCS 6000 | universal fire controlling unit | 600 µA |

¹⁾ maximum current drawn by element from detection line/loop of POLON 4000 system control panel.

²⁾ signalling device without additional power supply must be provided with line/loop current for alarming.



POLON-ALFA S.A.

POLAND 85-861 Bydgoszcz, ul. Glinki 155 | www.polon-alfa.pl
EXPORT DEP. phone no. +48 52 36 39 278, email: export@polon-alfa.pl
SERVICE DEP. phone no. +48 52 36 39 390, email: serwis@polon-alfa.pl