

UNIVERSAL SMOKE DETECTOR DUO-6046AD TYPE WITH G-40S BASE, BUILT-IN SOUNDER AND SHORT ISOLATOR

POLON 4000 and POLON 6000 INTERACTIVE FIRE DETECTION AND ALARM SYSTEM

INSTALLATION AND MAINTENANCE MANUAL

IK-E373-001GB

Issue 1



DUO-6046AD smoke detector with G-40S base and build-in sounder and short isolator, the subject of this manual, meet the essential requirements of the following regulations of the European Parliament and Council (EU) as well as European Union directives:

- CPR** CPR/305/2011 Regulation (EU) no. 305/2011 of the European Parliament and of the Council of 9 March 2011 laying down harmonised conditions for the marketing of construction products and repealing Council Directive 89/106/EEC;
- EMC** Directive (UE) 2004/108/WE relating to electromagnetic compatibility.

Declaration of Performance has been issued for DUO-6046, DUO-6646, and DUO-6043 smoke detectors.

DUO-6046AD smoke detectors have received the Certificate of Constancy of Performance issued by CNBOP-PIB, a Polish notified body no. 1438 in EU, confirming the conformity of the smoke detectors with the standard requirements of EN 54-7:2000 + A1:2002 + A2:2006 as well as EN 54-17:2005 + AC:2007.

The Certificate and the Declaration of Constancy of Performance are available at the internet site www.polon-alfa.pl

The contents of this manual should be thoroughly read and understood before installation and operation of the device.

Failure to follow the instructions included in this manual may be dangerous or result in the violation of applicable regulations.

As the manufacturer, Polon-Alfa is not liable for any damages resulting from the improper device operation that is not in accordance with this manual.

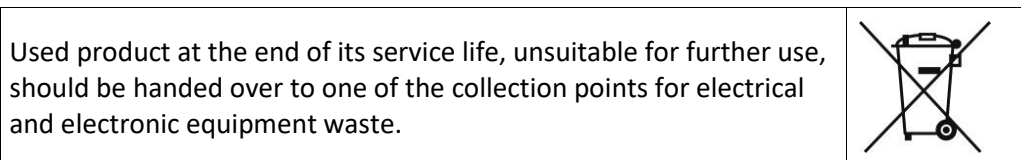

Note – This manual as well as the device are subject to change without notice.



18

Polon-Alfa S.A.
85-861 Bydgoszcz, ul. Glinki 155
1438
1438-CPR-0474

Smoke detectors
DUO-6046AD with G-40S base and built-in sounder and short isolator

EN 54-3

EN 54-7

EN 54-17

Declaration of Performance no. 1/E373/2018/PL

Product essential characteristic		Performance	Harmonised technical specification
1		Fire condition efficiency	
Sound level		Pass	4.2
Frequency and sound pattern		Pass	4.3
Repeatability		Pass	5.2
Functionality		Pass	5.3
Warning Signal and Message broadcasting		Not applied	C.3.1
Synchronisation (option with requirements)		Not applied	C.3.2
Announcement broadcast		Not applied	C.5.1
Warning Signal/silence/announcement sequence timeline		Not applied	C.5.2
Announcement synchronisation test (option with requirements)		Not applied	C.5.3
2		DurabilityNiezawodność eksploatacyjna	
Durability		Pass	4.4
Built		Pass	4.5
Markings and technical specification		Pass	4.6
Durability		Pass	5.4
General tests		Not applied	C.4
Nr.	Product essential characteristic	Performance	Harmonised technical specification
			EN 54-3:2001 A1:2002 A2:2006 chapter

3	Durability of operational reliability: heat resistance	
	Dry heat (resistance)	Pass 5.5
	Dry heat (strength)	Not applicable 5.6
	Cold (resistance)	Pass 5.7
	Moist cyclic heat (resistance)	Pass 5.8
	Moist cyclic heat (endurance)	Pass 5.9
4	Durability of operational reliability: moist resistance	
	Moist cyclic heat (resistance)	Pass 5.8
	Moist solid heat (strength)	Pass 5.9
	Moist cyclic heat (strength)	Not applicable 5.10
5	Durability of operational reliability: corrosion resistance	
	Corrosion caused by sulfur dioxide (durability)	Pass 5.11
6	Durability of operational reliability: shock and vibration resistance	
	Single strokes (resistance)	Pass 5.12
	Impact (resistance)	Pass 5.13
	Sinusoidal vibration (resistance)	Pass 5.14
	Sinusoidal vibration (endurance)	Pass 5.15
7	Durability of operational reliability: electrical stability	
	Electromagnetic compatibility (resistance)	Pass 5.16
8	Durability of operational reliability: ingress protection	
	Ingress protection	Pass 5.17
	Product essential characteristic	Performance Harmonised technical specification EN 54-7:2000 + A1:2002 + A2:2006 chapter
	Nominal commissioning/sensitivity, response delay (response time) and efficiency in fire conditions	
	Response to slow-developing fires	Pass 4.8
	Repeatability	Pass 5.2
	Directional dependence	Pass 5.3
	Reproducibility	Pass 5.4
	Resistance to air movement	Pass 5.6
	Resistance to glare	Pass 5.7
	Fire sensitivity	Pass 5.18
	Operation reliability	
	Tripping indicator	Pass 4.2
	Connection of auxiliary equipment	Pass 4.3
	Monitoring of detachable detectors	Pass 4.4
	Factory settings	Pass 4.5

Sensitivity adjustment at installation site	Pass	4.6
Product essential characteristic	Performance	Harmonised technical specification EN 54-7:2000 + A1:2002 + A2:2006 chapter
Protection against foreign body ingress	Pass	4.7
Labelling	Pass	4.9
Technical documentation	Pass	4.10
Additional requirements for software-controlled detectors	Pass	4.11
Power supply voltage tolerance		
Power supply parameter changes (resistance)	Pass	5.5
Durability, operation reliability and reaction delay; heat resistance		
Dry heat resistance	Pass	5.8
Low temperature resistance	Pass	5.9
Durability and operation reliability; vibration resistance		
Single impact resistance	Pass	5.13
Impact resistance	Pass	5.14
Sinusoidal vibration resistance	Pass	5.15
Sinusoidal vibration strength	Pass	5.16
Durability and operation reliability; moisture resistance		
Damp heat, constant test resistance	Pass	5.10
Damp heat, constant test resistance	Pass	5.11
Durability and operation reliability; corrosion resistance		
Resistance to corrosion induced with sulphur dioxide (SO ₂)	Pass	5.12
Durability and operation reliability; electrical stability		
Electrical compatibility (resistance)	Pass	5.17

Product essential characteristic	Performance	Harmonised technical specification EN 54-17:2005 + AC:2007 Chapter
Efficiency in fire conditions		
Reproducibility	Pass	5.2
Operation reliability		
Requirements	Pass	4
Durability and operation reliability: heat resistance		
Dry heat resistance	Pass	5.4
Low temperature resistance	Pass	5.5
Durability and operation reliability: vibration resistance		
Single impact resistance	Pass	5.9
Impact resistance	Pass	5.10
Sinusoidal vibration resistance	Pass	5.11
Sinusoidal vibration strength	Pass	5.12
Durability and operation reliability: moisture resistance		
Damp heat, cyclic test resistance	Pass	5.6
Damp heat, constant test resistance	Pass	5.7
Durability and operation reliability: corrosion resistance		
Resistance to corrosion induced with (SO ₂)	Pass	5.8
Durability and operation reliability: electrical stability		
Power supply voltage changes	Pass	5.3
Electromagnetic compatibility (EMC), immunity test	Pass	5.13
Intended use: Fire safety – a point smoke detector using scattered light for fire alarm systems in buildings.		
Technical data – see manual: IK-E360-001		

1 DESIGN

DUO-6046AD smoke detectors are designed to detect the initial stage of fire, where smoke appears. It features high resistance to air movement and pressure changes.

The division of detector types is based on their compatibility with different control panels and systems, and it is presented in the table below.

Detector type	Compatible systems/control panels		
	Control panels POLON-4100 POLON-4200	All control panels of 4000 SYSTEM	All control panels of 6000 SYSTEM
DUO-6046	YES	YES	YES
DUO-6646			YES
DUO-6043	YES		

DUO-6043 universal smoke detectors do not support interactive alarm variants. All other parameters of DUO-6046, DUO-6646 and DUO-6043 detectors are the same.

All detectors are equipped with an internal short-circuit insulator.

The DUO-6046, DUO-6646 and DUO-6043 detectors will be collectively referred to as "detector" without giving a specific name.

2 TECHNICAL DATA

Operating voltage	16.5 V – 24.6 V
Maximum current consumption	≤ 150 μA
Maximum installation height ¹⁾	11 m ¹⁾
Maximum monitoring area ¹⁾	about 60 m ² – 80 m ² ¹⁾
Operating temperature:	–25°C to +55°C
Permissible relative humidity	To 95% at 40°C
Dimensions (w/o base)	(Ø 115×44) mm
Possible combinations of operating modes	64
Weight (w/o base)	0.2 kg
Standard detector colour	White
Address encoding method	Programmable from the control panel
Suitability for test fire detection	TF1, TF2, TF3, TF4, TF5, TF7, TF8, TF9

¹⁾ Refer to applicable design guidelines SITP WP-02

3 DESCRIPTION OF THE DESIGN

The main part of the detector is an optical system consisting of two light-emitting diodes, emitting light in ultraviolet and infrared range, as well as a photodiode that works as a receiver. These diodes are mounted in the holder in such a way that the light emitted by transmitting diodes does not directly reach the receiver diode. Detection system (holder with diodes) is attached directly to the printed circuit board with electronics and a processor monitoring the operation of the detector. The labyrinth

prevents external light from getting into the detection system. Metal mesh prevents small insects and larger contaminants from entering the detection system. The element is located inside a white plastic enclosure, which consists of a basket, a detector shield and a screen.

The detector works with G-40 base to which detection line is connected.

4 DESCRIPTION OF THE OPERATION

The optical smoke detector is based on the Tyndal principle of scattering light rays on smoke particles. The main part of the detector is an optical system consisting of two light-emitting diodes, emitting light in ultraviolet and infrared range, as well as a photodiode that works as a receiver.

The optical system and the measuring chamber around it are guarded with a labyrinth. The structure of the optical labyrinth ensures attenuation of external light and light coming from internal reflections of light emitted by transmitting diodes. Smoke particles entering the measuring chamber reflect the light emitted by the transmitting diodes. Reflected light reaches the photodiode causing the formation of photocurrent, which, after amplification and conversion into digital signal, is analyzed with a microprocessor inside the detector.

The alarm status of the detector is indicated with a flashing red light from two LEDs located on opposite sides of the detector housing. The indicator is designed to quickly locate the alarming detector and help with periodical functional test of the detector. If the detector is hardly visible or installed in a hard-to-reach area, it can be connected with an additional remote alarm indicator, installed in an accessible and visible area.

The communication between POLON 4000 or 6000 control panel and detectors is carried out via an addressable two-wire detection line. Unique, fully digital communication protocol enables transferring any information from the control panel to the detector and from the detector to the control panel. In addition to sending the evaluation of the state of fire factors and trends in their environment to the control panel, on request the detector can also send the current analog value.

The microprocessor, controlling the operation of the detector checks for the correct operation of its basic systems and, in case of any irregularities, provides relevant information to the control panel.

The smoke detector is an analog detector with a digital self-adjustment mechanism, i.e. it keeps the sensitivity constant when the measuring chamber gradually gets more contaminated. When the technical alarm threshold is exceeded, the detector will send the information to the POLON 4000 or 6000 system control panel about partial contamination of the measuring chamber. This signal is generated in order to inform the maintenance department that getting contaminated and not taking appropriate actions can lead in the future to the situation where the detector will not be able to keep all its parameters at the declared level. However, it should be emphasized that the detector will be fully operational for about 1/3 of the time that has passed since the last maintenance.

The detector is equipped with an internal short-circuit insulator that separates the operational part of the detection line from the adjacent short-circuited part, which enables its undisturbed operation. The alarm state is indicated with flashing red LED. Fault, technical alarm and short-circuit states of the short-circuit insulator are indicated with flashing yellow LED.

5 OPERATING CONDITIONS

During operation of detectors do not allow to form dew and rime on the detector surface and protect it against excessive dust contamination.

When carrying out any repair work, the detector must be removed or properly secured with the shield provided for this purpose. Shields can be obtained from the installer or purchased from the manufacturer. If the detector is removed, the socket should be secured against painting with a painting tape. Detectors damaged during painting and repair works by workers carrying out these works (e.g. painted detector enclosure, mesh sealed with paint, etc.) are not subject to warranty.

The universal smoke detector should be periodically inspected during operation in accordance with z PKN-CEN/TS 54-14:2006, which is carried out in order to determine the proper operation of the detector as well as its proper cooperation with the control panel.

Smoke detector operation test can be carried out with a smoke imitator.

The detector is equipped with a magnetic field sensor to enable testing the detector communication with the control panel and check its location within the premises of the facility with a service kit. After placing the tester head on it, yellow LED starts flashing, which denotes correct communication with the control panel.

Long-term operation may cause dust to accumulate inside the smoke detector. When self-adjustment range is exceeded, as a result of gradual contamination of the smoke detector, it is switched to technical alarm state, and information about excessive contamination is sent to the control panel. The control panel indicates the need for cleaning of the detector optical system, i.e. labyrinth, holder, transmitting diode and photodiode lenses. Maintenance actions should be taken as soon as possible in order to prevent false alarms.

Figures 1 and 2 show how to assemble and disassemble the detector. In order to disassemble the detector, perform the following:

- a) Press the clip (Figure 1) and turn the shield in the basket to the right until the shield is removed.
- b) Remove the mesh from the labyrinth.
- c) Turn and remove the labyrinth.
- d) Carry out necessary cleaning.

For cleaning, it is recommended to use a gentle brush and a vacuum cleaner. Compressed air may also be used. Labyrinth can be washed with warm water with the addition of some dishwashing liquid. After washing and drying, there must be no leaks on the inner surfaces of the labyrinth.

After cleaning, the detector must be assembled. To do this:

- a) Place the labyrinth in the guides and rotate to a perceptible click.
- b) Put the mesh on the labyrinth.
- c) Insert the shield into the basket so that the tripping indicator diode is a bit to the right off the window.
- d) Turn the shield to the left.

After installation, check the detector operation using a smoke imitator.

NOTE – If cleaning does not produce desired results, send the detector to the manufacturer for repair.

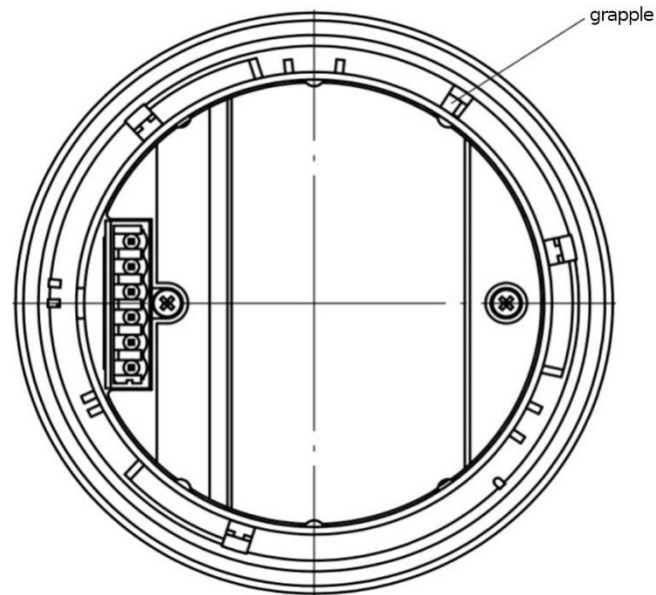

Figure 1. Underside view of the detector

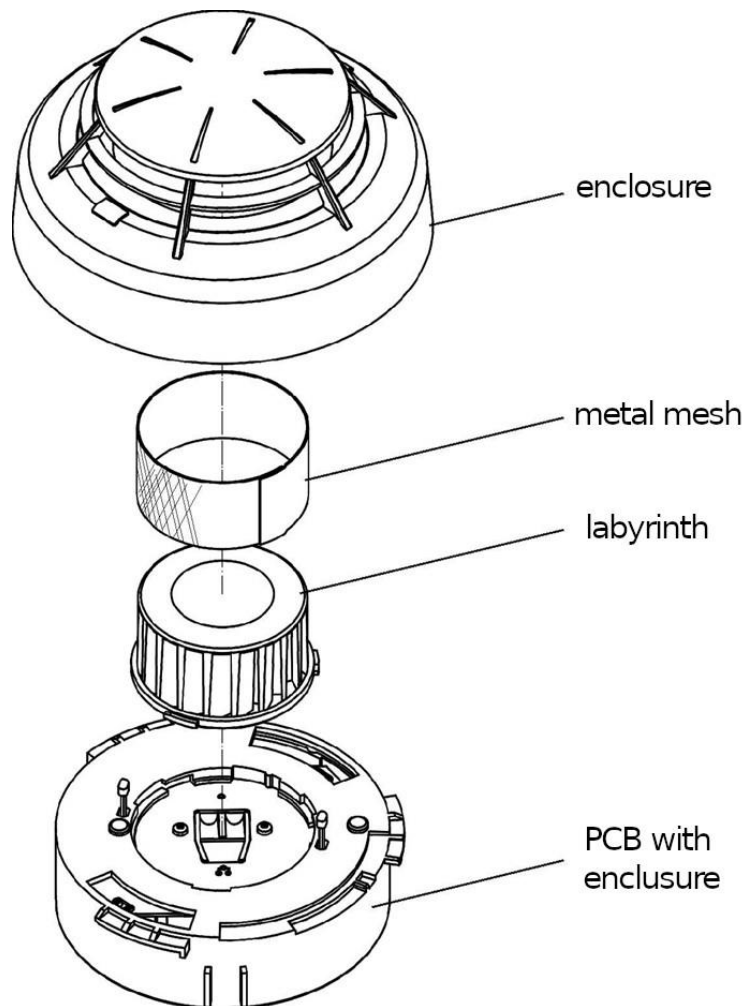

Figure 2. Detector components after disassembly

6 DETECTOR OPERATING MODES

The configuration of the detectors operating mode depends on the system (4000 or 6000) where the detector operates. Its configuration for the 4000 system includes only smoke sensor setting, while in case of 6000 system it additionally includes the WZ output setting.

6.1 OPERATION IN THE 4000 SYSTEM

The detector features several operating modes (apart from control panel alarm variants) that allow the user to better adjust its characteristics to operating conditions in a specific environment:

Smoke sensor selection (at least 1 must be selected):

- IR smoke sensor: YES/NO
- UV smoke sensor: YES/NO

Interaction:

- **Independent sensors (0)** – sensors operate independently (OR function)
- **Interdependent sensors (1)** – increasing the fire factor on one sensor makes the other sensor sensitive and accelerates the fire detection
- **Sensors in coincidence (2)** – sensors operate in coincidence (AND function); to trigger an alarm with a detector, the alarm threshold for two sensors must be exceeded. It is used to increase immunity to false alarms.

Sensitivity:

- Normal
- increased by 20%
- reduced by 20%
- reduced by 40%

Based on activated sensors, the suitability of the detector for detecting fires at normal sensitivity is shown in the following table.

Mode	Sensor switched on		Interaction	Fire detection suitability								
	O _{UV}	O _{IR}		TF1	TF2	TF3	TF4	TF5	TF6	TF7	TF8	TF9
01	YES	NO	Independent sensors (0)	++	++	+++	+++	+++		+++	+++	+++
02	NO	YES	Independent sensors (0)		++	++	+++	+++		+++	+++	++
43	YES	YES	Interdependent sensors (1)	++	+	++	+++	+++		+++	+++	+++
83	YES	YES	Sensors in coincidence (2)		++	++	+++	+++		+++	+++	++

6.2 OPERATION IN THE 6000 SYSTEM

In case of the 6000 system, the detector mode consists of the sensor configuration, just like in the 4000 system,

and additionally WZ output is configured.

WZ output operating mode:

- **as in the 4000 system** – WZ flashes like the LED in the alarm reporting detector
- **duplication of the red LED flash** – WZ flashes like the LED in the alarm reporting detector, but a **multi-tripping indicator connected to the positive terminal of power supply is to be used**
- **flashes independent of the alarm**, but an **output group** must be declared.

7 DETECTOR INSTALLATION

Detectors are installed (in terms of height, placement) according to SITP guidelines WP-02. The detectors are to be installed in rooms where equipment and stored materials will emit visible smoke in case of fire. If it is difficult to determine the most probable fire factor (smoke type) that may be formed during the first phase of fire development, appropriate tests with several types of detectors should be carried out (at the design stage) or mixed protection with e.g. optical and ionization detectors should be applied.

Detectors can operate in loops, loops with side lines or in open detection lines of POLON 4000 system control panels. (See Operation and Maintenance Manual of POLON 4000 and POLON 6000 control panel.)

Detectors are installed in G-40 bases. The connection method of the detection line is described in the Installation and Maintenance Manual of the G-40 base. Additional optical indication of a single detector or a group of detectors can be achieved by connecting the WZ-31 remote alarm indicator:

– standard configuration of the tripping indicator

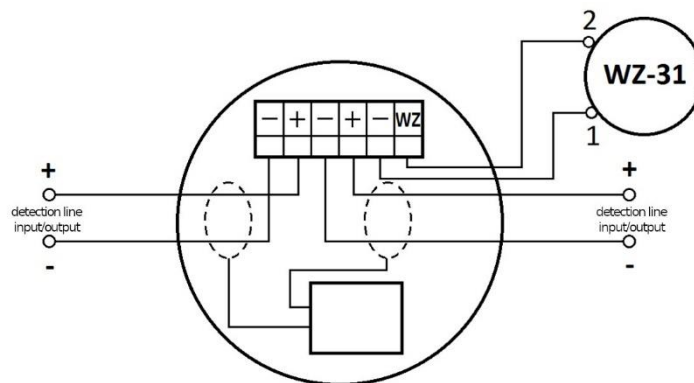

Figure 3. Wiring diagram for a detector operating with POLON 4000 system only.

– multi-tripping indicator connected to the positive terminal of power supply:

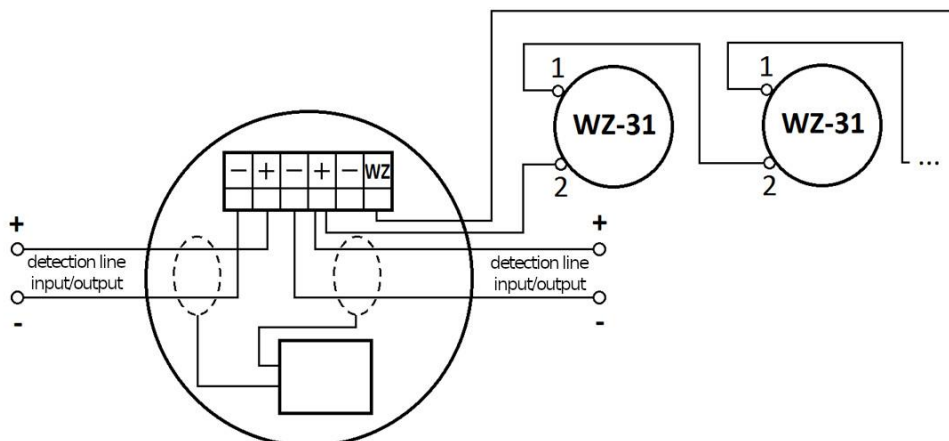

Figure 4. Wiring diagram for a detector operating in the 6000 system with additional WZ modes. It is possible to connect 2 to 5 remote alarm indicators.*

* For more details please refer to the POLON 6000 configuration manual

Alarm system cables should be laid in accordance with the regulations applicable to low-voltage installations (below 42 V).

NOTE – Detectors should not be installed in rooms with corrosive atmosphere, containing corrosive gases, corrosive fumes or dust. Water vapour condensation is not permitted in case of detectors.

8 SAFETY CONDITIONS

8.1 Repair and maintenance

Maintenance and periodic inspections must be carried out by personnel that is authorised or trained by Polon-Alfa.

All repairs must be carried out by the manufacturer.

Polon-Alfa is not responsible for the operation of the equipment maintained and repaired by unauthorized personnel.

8.2 Work at height

Work at height related to the installation of detectors must be carried out with special care using equipment and tools in sound condition.

Please pay particular attention to the stability of ladders, elevators, hoists, jacks, etc.

Power tools should be used in accordance with safe working conditions specified in relevant manufacturer's manuals.

8.3 Eye protection against dust

Protective goggles and dust masks should be worn during work that produces large amount of dust, especially when drilling holes in ceilings in order to fix enclosure bodies of detector bases.

8 STORAGE AND TRANSPORT

8.1 Storage

Detectors should be stored in closed rooms, with no corrosive fumes or gases, at the temperature range from 0°C to +40°C, with relative humidity not exceeding 80% at 35°C.

A detector should not be exposed to direct sunlight or heat from heating equipment during storage.

Detector storage time in transport packaging should not exceed 6 months.

8.2 Transport

Detectors should be transported in closed spaces of transport vehicles, in a packaging corresponding to the requirements of the applicable transport regulations. Transport temperature should not fall below -40°C or exceed +70°C and the relative humidity should not exceed 95% at +45°C or 80% at +70°C.



POLON-ALFA S.A.

POLAND 85-861 Bydgoszcz, ul. Glinki 155 | www.polon-alfa.pl
EXPORT DEP. phone no. +48 52 36 39 278, email: export@polon-alfa.pl
SERVICE DEP. phone no. +48 52 36 39 390, email: serwis@polon-alfa.pl