

DOR-4043

ADDRESSABLE MULTI-STATE OPTICAL SMOKE DETECTOR

POLON 4000 and POLON 6000 INTERACTIVE FIRE DETECTION AND ALARM SYSTEM

INSTALLATION AND MAINTENANCE MANUAL

IK-E282-002GB

Issue IIIA



The DOR-4043 addressable optical smoke detector covered by this manual, complies with the requirements of the following European Union directives:

CPD 89/106/EWG - on construction materials;
EMC 2004/108/WE - on electromagnetic compatibility.

The DOR-4043 addressable optical smoke detector has been approved with the EC Certificate of Conformity No. 1438/CPD/0014, issued by the Scientific and Research Centre for Fire Protection (CNBOP) Józefów, Poland, an EU notified authority No. 1438, confirming its compliance with the requirements of the PN-EN 54-7: 2004 standard.

The certificate can be download form www.polon-alfa.pl web site.

 1438
Polon-Alfa Spółka z ograniczoną odpowiedzialnością Sp. k. 155, Glinki Street, PL 85-861 Bydgoszcz, POLAND 05 1438/CPD/0014
EN 54-7 DOR-4043 Optical Smoke Detector (addressable multi-state detachable, utilising diffused light effect Application – fire security
Technical data - IK-E282-002GB manual

Read the manual carefully before assembling and activation of the detector.

Any nonconformity with the instructions contained in the manual may be harmful or may cause violation of the law in force

POLON-ALFA shall not bear responsibility for any harms resulted from the unit application discordantly to the requirements of this instruction.

<p>A waste product, unsuitable for further use, shall be passed to a waste electric and electronic equipment collection point.</p>	
--	---

NOTE: The manufacturer reserves the right to change specifications of products at any time without prior notice.

1 PURPOSE

The DOR-4043 microprocessor based, interactive optical smoke detector is designed for detection of a visible smoke that is concurrent with most fire combustion. It enables a fire detection at a start of its flameless stage when material starts to smoulder, and therefore generally, a long time prior to the appearance of an open flame and a noticeable rise in temperature. The detector is characterised by a high resistance against wind, pressure change and steam condensation. It is very sensitive to visible smoke.

The DOR-4043 addressable optical smoke detectors operate only in addressable lines/loops of the POLON 4100 and POLON 4200 fire detecting and alarm systems. They are equipped with short circuit isolators.

2 TECHNICAL SPECIFICATIONS

Operating voltage	16.5 V ÷ 24.6 V
Maximum quiescent current	≤ 150 µA
Maximum installation height *)	12 m
Maximum supervised area *)	60 ÷ 80 m ²
Operating temperature range	from -25 °C to +55 °C
Allowable relative humidity	up to 95 % at 40 °C
Dimensions (without base)	Ø 115 mm x 43 mm
Number of sensitivity levels	3
Mass (without base)	0.2 kg
Standard colour	white
Address coding method	programmable at the control panel

*) see the design guidelines

3 SAFETY CONDITIONS

3.1 Repairs and maintenance

Any maintenance works or periodic inspection shall be executed by skilled personnel employed by companies being authorised and trained by POLON-ALFA.

Any repair must be carried out by the manufacturer.

POLON-ALFA bears no responsibility for the operation of any apparatus being serviced and repaired by unauthorised personnel.

3.2 Works at height

Any detector installation works carried out at height must be executed with particular care utilising tools and machinery in good working condition.

Special attention shall be given to the stability of ladders, platforms, lifts, etc.

Any electric tools shall be used strictly obeying the safety rules specified in the manufacturer instruction manuals.

3.3 Anti-dusting eye protection

It is obligatory to use protective anti-dusting glasses and masks during detector installation works that produce high amount of dust, such as hole drilling for detector base mounting on ceilings.

4 CONSTRUCTION DESCRIPTIONS

The detector mechanical construction is shown in Fig. 1. Its basic element is a detecting optical module consisting of transmitting infrared diode and a photodiode acting as a receiver. They are mounted in a holder in such a way that radiation emitted by the transmitting diode does not reach the other diode directly. The detecting module (holder with diodes) is fastened to a printed board that contains all electronic elements and a circuit with the detector monitoring processor. The optical module is protected by a labyrinth, damping external radiation. A metal protective net prevents irruption of small insects or pieces of dirt into the detecting module. The whole structure is placed in a white plastic housing containing a basket, screen and detector cover.

The DOR-4043 detector is installed in the G-40 base where detecting line cables are connected to.

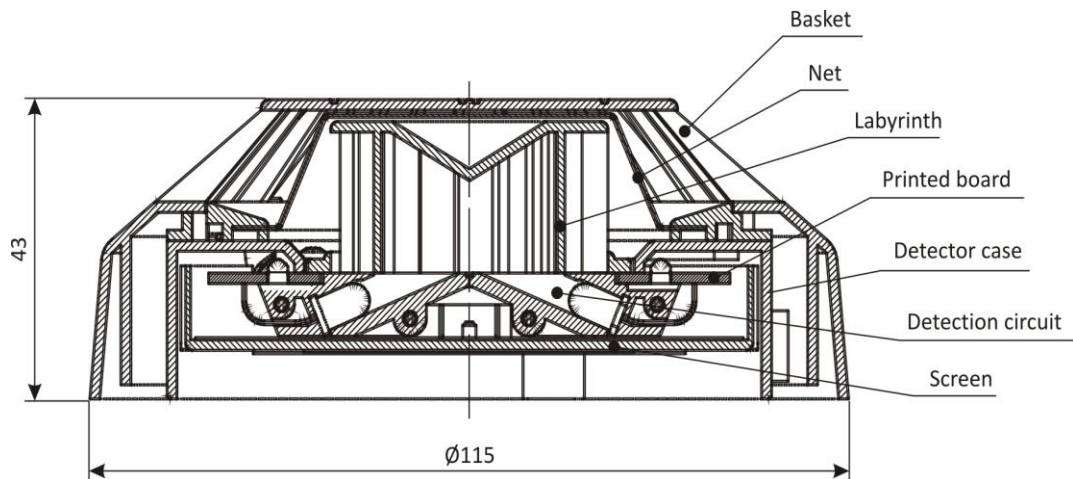

Fig. 1 DOR-4043 detector main elements

5 PRINCIPLE OF OPERATION

The DOR-4043 is a Tyndall effect based optical smoke detector – light ray scattering on smoke particles. Its basic element is a detecting optical module consisting of an electroluminescence diode that transmits infrared radiation and an optical receiving diode. The optical module and surrounding measuring chamber are protected by a labyrinth which is shaped to dump both external light and radiation resulting from internal reflexes of the transmitting diode light. When smoke particles enter the measuring chamber, they reflect the light emitted by the transmitting diode. The reflected light reaches the optical diode producing photocurrent which is first strengthened and processed, and then analysed by the microprocessor installed inside the detector.

The alarm mode is indicated with pulse red light emitted by a signalling diode installed on the detector casing. The indicator enables fast location of the activated detector and is helpful in periodic detector

inspections. In case the detector is hardly visible or is installed in a difficult-to-reach space, an additional optical alarm indicator (WZ-31) may be connected in an accessible and visible place.

Communication between the POLON 4100/POLON 4200 fire alarm control panel and the DOR-4043 detectors is obtained with an addressable two-wire detection line. Unique, fully digital communication protocol enables passing any information from the fire alarm control panel to the detector and inversely.

Apart from transmitting an evaluation of fire factors and tendency of their changes, the detector passes to the control panel, on its request, the current analogue value.

The detector operation controlling microprocessor monitors correctness of its basic circuits operation and, in case an irregularity is found, reports relevant information to the control panel.

The DOR-4043 is an analogue detector with an automatic sensitivity self-regulation digital mechanism that is it maintains a constant sensitivity level during progressing dirt build-up in the measuring chamber.

After exceeding a pre-set threshold of technical alarm, the detector transmits a signal to the POLON 4000 system control panel denoting the measuring chamber partial contamination. The signal is generated in order to inform the servicing personnel that the detector parameters shall not remain at the declared level in case the dirt build-up tendency is maintained and appropriate measures are not taken. It must be stressed that the detector shall be fully efficient within ca. 1/3 of the time period that passed since the latest maintenance works.

The detector is equipped with an internal short circuit isolator that cuts off an efficient part of a detection line from the adjacent shorted section what enables further undisturbed detector operation.

The detector alarm mode is signalled with flashing red light of the illuminating diode. The fault mode, technical alarm and an actuation of a short circuit isolator are signalled with yellow flashes of the diode.

The detector sensitivity level is adjustable. Its sensitivity is settled from the control panel level choosing one of available sensitivity levels: 1st operation mode – normal sensitivity, 2nd operation mode – increased sensitivity, 3rd operation mode – decreased sensitivity.

The detector operation modes (besides the control panel alarm variants) entails that the user is able to adapt, in the best way, its operation characteristics to operation in the determined environment.

6 OPERATION AND MAINTENANCE CONDITIONS

During the detectors operation it is obligatory to avoid creation of dew or rime on the detector surface as well as to protect against excessive contamination with dust.

In the time of any repair works, the detector should be taken out or protected with provided-for-this-purpose cover. Such a cover can be obtained from an installer or purchased from the manufacturer. In case the detector is taken out, its base should be protected against being painted utilising a painting tape. Detectors which are damaged during painting and renovation works due to a fault of the persons executing such works (e.g. painted detector casing, stuck-with-paint net, etc.) are not subject to warranty repairs.

During the operation life, the DOR-4043 addressable optical smoke detector should be subjected to periodical inspection according to PKN-CEN/TS 54-14:2006 standard, which is executed in order to confirm the detector proper operation and its appropriate interoperation with the control panel. The inspection should be carried out at least every 6 months.

The detector operation is tested with a smoke simulator or smoke generator.

Long-lasting operation of the DOR-4043 optical smoke detector may result in dust accumulation inside its internal optical chamber. After exceeding the self-regulation range due to the chamber contamination progress, the detector triggers the technical alarm mode sending excessive contamination information to the control panel. It causes a necessity to clean the detector optical module: the labyrinth and the lenses of both diodes – transmitting one and photodiode. A failure to carry out the servicing works may result in false alarm evoking in future.

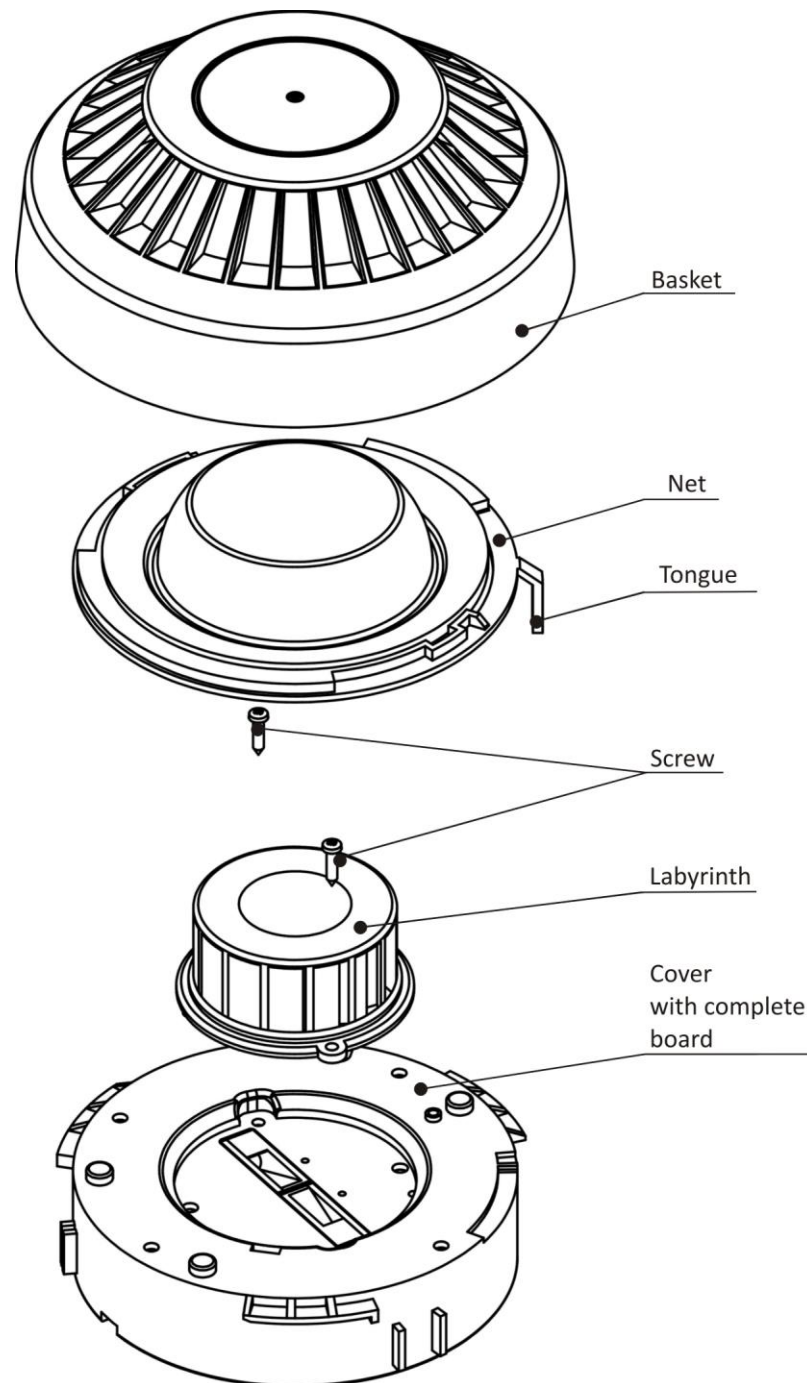

Fig.2 Detector elements after dismantling

The detector assembling and dismantling is shown in Fig. 2.

In order to dismantle the detector it is necessary:

- a) pressing the net long clinch, to turn the cover right in the basket until it is taken out;
- b) to remove two screws that fix the labyrinth and take the labyrinth out;
- c) to perform the necessary cleaning.

A delicate brush as well as vacuum cleaner are recommended for cleaning. Compressed air can be possibly used. It is permitted to wash the labyrinth with warm water with addition of washing-up liquid. No damp patches should remain on the labyrinth internal surfaces after washing and drying.

After cleaning the detector should be assembled, its functioning should be tested using a smoke imitator or smoke generator and installed again into the detection line.

In this order to assemble the detector, it is necessary to:

- a) fasten the labyrinth with two screws;
- b) place the basket in the reverse position as that shown in the figure;
- c) insert the net into the basket paying attention to its positioning – alignment with the juts;
- d) insert the cover into the basket so that the illuminating diode is placed a little to the right in relation to the glass;
- e) turn the cover to the left.

Note – In case the cleaning does not produce the required result, it is necessary to send the detector to the manufacturer for repair.

7 DETECTOR INSTALLATION

The DOR-4043 detectors are installed (height, arrangement) according to the guidelines settled by the Scientific and Research Centre for Fire Protection. They are mounted in premises where the working equipment or stored materials may emit visible smoke when a fire occurs. In case it is difficult to determine the most probable fire factor (smoke type) that is likely to occur in the first fire development phase, special tests should be carried out (at a designing stage) using various type detectors or mixed protection (e. g. with optical and ionisation detectors) should be applied.

The detectors are intended to operate in loops, in loops with straight branches or in radial detection lines of the POLON 4100 and POLON 4200 control panels (see the POLON 4100/POLON 4200 control panel Installation and Maintenance Manual).

The detectors are installed in the 40 model range bases. The detection line connection is presented in the G-40 base Installation and Maintenance Manual. An additional optical alarm signal of a detector or a group of detectors can be obtained by connecting the WZ-31 alarm indicator.

Alarm system cables are routed in accordance with the regulations obligatory for low voltage (below 42 V) systems.

Note – The detectors should not be installed in corrosive atmosphere that contains caustic gases and vapours as well as dust. Steam condensation on detectors is impermissible.

8 STORAGE AND TRANSPORTATION

8.1 Storage

The DOR-4043 detectors must be stored in closed rooms free of any caustic gases and vapours, at ambient temperature between 0 °C and +40 °C and relative humidity not exceeding 80 % at + 35 °C.

The detectors shall not be exposed to direct sunlight or heat emitted by heaters.

The storage period of the detectors in transport package should not exceed 6 months.

8.2 Transportation

The DOR-4043 detectors should be carried in closed spaces of transport means in proper packing that meet appropriate transport regulations. Transport temperature shall not be lower than - 40 °C and higher than + 70 °C; relative humidity shall not exceed 95% at + 45 °C or 80 % at + 70 °C.

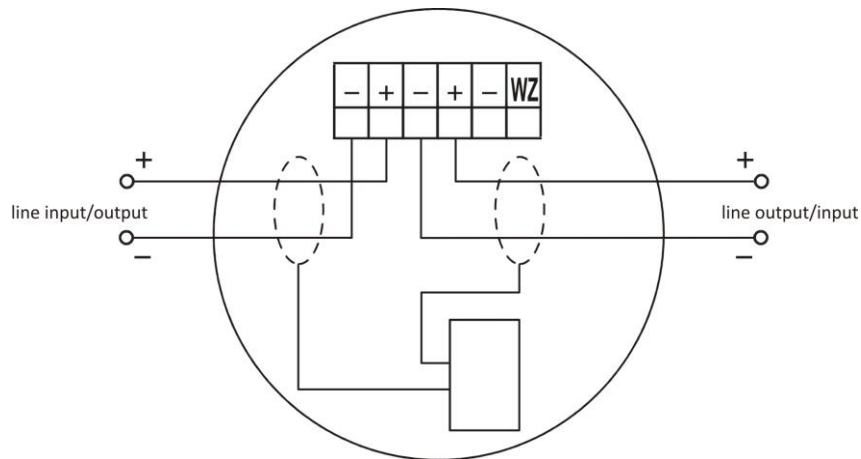

Fig. 3 Clamps of base interoperating with DOR-4043 plug



POLON-ALFA S.A.

POLAND 85-861 Bydgoszcz, ul. Glinki 155 | www.polon-alfa.pl
EXPORT DEP. phone no. +48 52 36 39 278, email: export@polon-alfa.pl
SERVICE DEP. phone no. +48 52 36 39 390, email: serwis@polon-alfa.pl