



INTERACTIVE FIRE ALARM SYSTEM

POLON 4000

PARALLEL INDICATION TERMINAL

TSR-4000

Installation and Maintenance Manual

ID-E305-001-GB

Edition VII

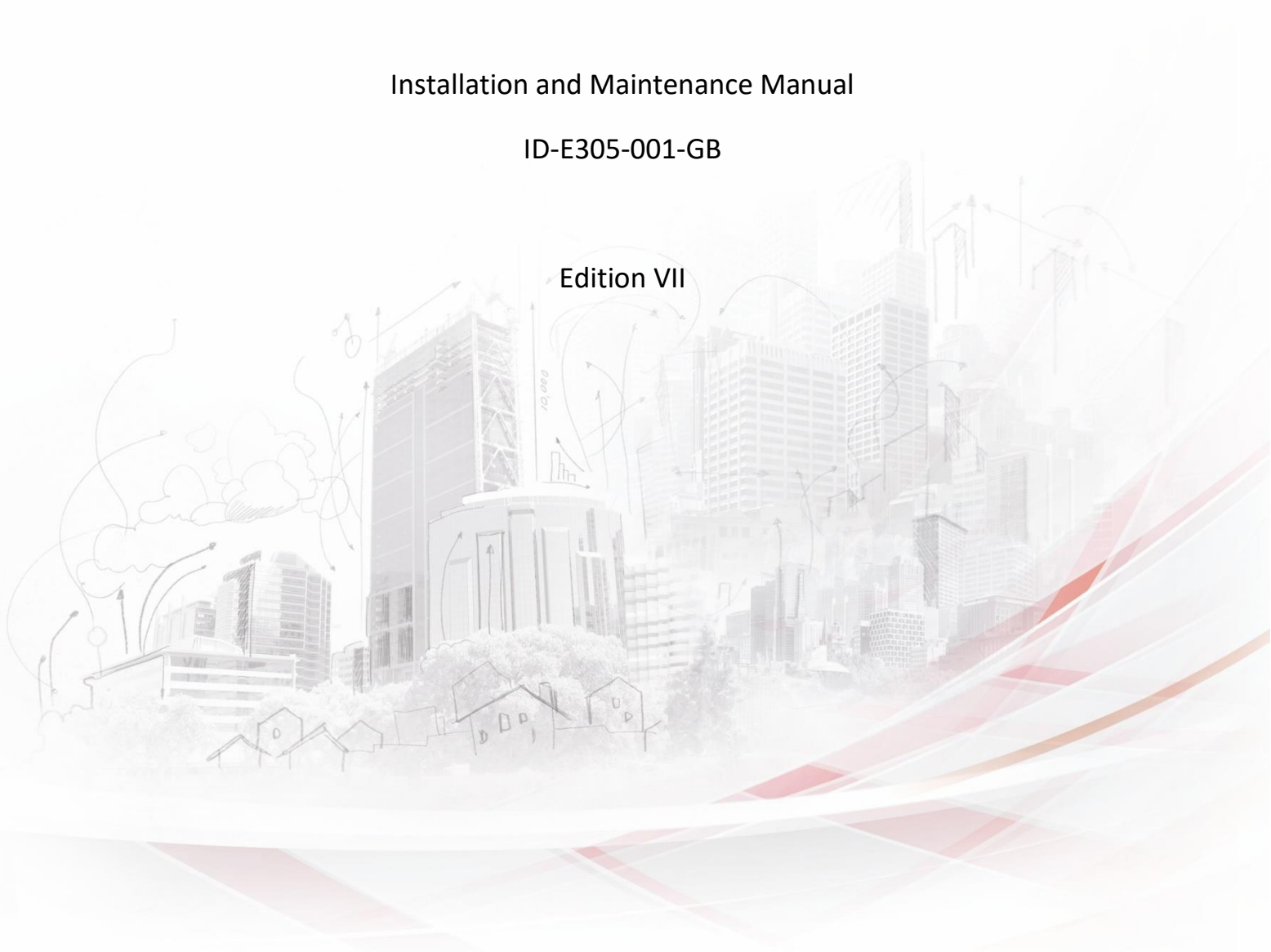

The TSR-4000 parallel indication terminal, which is the subject of this IMM, meets the requirements of the National Technical Assessment CNBOP-PIB-KOT-2017/2022/0033-1002 edition 1 and the essential requirements of the European Union directives:

- LVD** Directive 2014/35/EC concerning electrical equipment intended for use within certain voltage limits;
- EMC** Directive 2014/30/EC on electromagnetic compatibility.

The TSR-4000 parallel indication terminal was issued by CNBOP-PIB in Józefów, an accredited unit No. AC 063, a national certificate of constancy of performance confirming the possession of technical features/parameters in accordance with the requirements of the National Technical Assessment. The possessed features/technical parameters exceeding the requirements of the above-mentioned standards and the National Technical Assessment and other features/parameters of the product specified in this manual not specified in the above-mentioned standards and the National Technical Assessment are confirmed by the Manufacturer.

The product has an approval certificate issued by CNBOP-PIB.

The manufacturer issued a national declaration of performance for the product.

The certificate, the certificate of approval and the declaration of performance are available on the website of www.polon-alfa.com

Before starting installation and operation, read the contents of this manual.

Failure to follow the recommendations in this manual may prove dangerous or result in a violation of applicable regulations.

The manufacturer POLON-ALFA is not responsible for damage caused as a result of use inconsistent with these instructions.

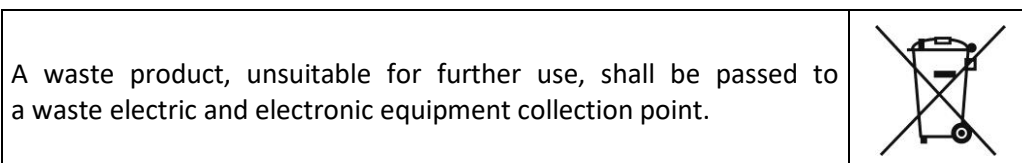

NOTE: The right to make changes is reserved

CONTENTS

1 INTRODUCTION	5
1.1 Documentation contents.....	5
1.2 Terminal application	5
1.3 Safety conditions	5
1.3.1 Electric shock protection.....	5
1.3.2 Installation and equipment safety.....	5
1.3.3 Repairs and maintenance.....	5
1.3.4 Fuse replacement	5
1.4 Definitions	6
2 DEVICE COMPLETENESS	7
3 TECHNICAL SPECIFICATIONS.....	8
4 DESIGN DESCRIPTIONS.....	8
4.1 Mechanical design	8
4.2 Handling and signalling elements, access levels.....	8
5 FUNCTIONALITY DESCRIPTIONS.....	10
5.1 General descriptions	10
5.2 Front panel elements	11
5.2.1 Handling elements.....	11
5.2.2 Signalling elements.....	13
5.3 Handling elements inside terminal	14
5.3.1 TSG-4000 main controller board.....	14
5.3.2 TPZ-4000 power supply, serial interfaces and outputs board.....	17
5.4 Alphanumeric LCD display	19
5.5 Terminal operation modes	20
5.5.1 REMOTE operation mode.....	20
5.5.2 LOCAL operation mode	21
5.5.3. Operation mode programming.....	22

5.6 Control panel and terminal operation modes signalling.....	23
5.6.1 Supervision (quiescent mode)	23
5.6.2 Alarming	24
5.6.3 Fault.....	27
5.6.4 Disablement	30
5.6.5 Testing (tests).....	31
5.6.6 Technical alarm	32
5.7 Control panel event memory /alarm memory readout	33
5.8 Terminal outputs	34
5.8.1 PKA non-potential monitored relay alarm output	34
5.8.2 PKU non-potential relay fault output	35
5.8.3 LS potential monitored output	35
5.8.4 Terminal outputs programming	36
6 POWER SUPPLY	38
7 INSTALLATION	39
7.1 Terminal mounting.....	39
7.2 Input and output circuit connecting clamps	40
7.3 The terminal connection with the control panel.....	42
7.3.1 Connection by a screened cable	42
7.3.2 Connection with optic fibres	44
8 OPERATION AND MAINTENANCE	50
8.1 Proper operation rules	50
8.2 Periodic inspections and maintenance rules.....	50
9 PACKING, STORAGE AND TRANSPORTATION	50
9.1 Packing	50
9.2 Storage regulations	51
9.3 Transport principles	51

1 INTRODUCTION

1.1 Documentation contents

The subject of this Operation and Maintenance Documentation (OMD) is the TSR 4000 parallel indication terminal, which constitutes a part of the POLON 4000 fire detection and alarm system. The OMD is suitable for designers, installers and maintenance technicians. It contains information necessary for the terminal proper installation, servicing and operation.

1.2 Terminal application

The TSR 4000 parallel indication terminal (called hereinafter 'terminal') is a micro-processor based device designed for interoperation with the POLON 4000 system following control panels: 4800 supported by at least 3.0 version software, POLON 4900, POLON 4200 and POLON 4100, as a remote signalling and handling tool.

The terminal is adapted to operate in closed premises of low dusting level at ambient temperature from - 5 °C to + 40 °C and relative humidity up to 80 % at +40 °C.

1.3 Safety conditions

1.3.1 Electric shock protection

TSR 4000 parallel signalling terminals are classified as devices of protection class I and can be used only in the case of additional electric shock protection in the form of zeroing or protective earthing.

The insulation of the circuits supplying the 230 V / 50 Hz electrical network is reinforced and withstands a test voltage of 2800 V, and the insulation of the low-voltage circuits (below 42 V) withstands a test voltage of 700 V DC.

After connecting the power grid wires, the mains connection should be protected with a factory cover.

1.3.2 Installation and equipment safety

The wiring installation should be made of wires with the required fire resistance and it should be properly protected when crossing the fire zone borders. In order to prevent unwelcome effects, the distance between the low-voltage installation and the power and lightning protection systems should be kept as required. Taking into account system resistance to electromagnetic interference, it is recommended to use protective grounding. The reserve batteries cluster must be connected to the unit during the final installation process stages.

The components of this unit are high-temperature sensitive. The maximum ambient temperature must not exceed 40 °C. The air humidity in the rooms where the unit operates must not exceed 80 %. It is forbidden to put any objects on the device; it must be also protected from water penetration inside the terminal.

1.3.3 Repairs and maintenance

Maintenance works and periodical inspections should be conducted by the authorised employees of companies which have been authorised or trained by POLON-ALFA. All repair works must be done exclusively by the manufacturer. POLON-ALFA does not bear any responsibility for the operation of devices maintained and repaired by unauthorised personnel.

1.3.4 Fuse replacement

When replacing fuses, it is obligatory to use replacements of the appropriate type and nominal value. The appropriate types and nominal values are contained in point 8.1 of this Documentation.

1.4 Definitions

Addressable detection line - A detection line that enables connection of addressable elements.

Side detection line - A detection line for two-state non-addressable fire warning devices, created using the ADC-4001 adapter.

Addressable element - An element operating in a detection addressable line possessing a unique and unchangeable identifier, i.e. serial number, and the element number defined during its configuration. An addressable element enables two-way exchange of digital data with the control panel (transmission and reception).

Line element - An element installed in detection addressable lines (addressable element) and side lines (non-addressable element).

Serial number - A unique 12-digit number assigned to each addressable element during the production process. The serial number contains the addressable element type identified by the control panel.

Line number - An ordinal number of the range of 1 ÷ 8 (POLON 4900) or 1 ÷ 4 (POLON 4200), or 1 ÷ 2 (POLON 4100) assigned to open or loop-shaped detection lines. The line numbering is linked with the MSL-1M (1 ÷ 4) and MSL-2M (5 ÷ 8) modules for the POLON 4900, MSL-42-1 (1 ÷ 4) for the POLON 4200 MLS-41 (1 ÷ 2) for POLON 4100 control panel.

Element number - An ordinal number of the range 1 ÷ 127 (POLON 4900) or 1 ÷ 64 (POLON 4200, POLON 4100), assigned to an addressable element when a detection line is configured. During normal operation, the control panel communicates using the element number.

Address space - A set of number pairs containing a line number and element number that define all possible program locations of the elements within an installation.

Zone - A separated section of the protected premises to which defined line elements are assigned.

Non-maskable fault - A fault connected with the EKS-4001 elements or LK monitoring lines of the POLON 4900, POLON 4200 or POLON 4100 control panels.

Standard configuration - A set of data defining the control panel or terminal equipment furnishing and its operation organisation (e.g. addressable elements declaration, assignment of elements to zones, alarming variants) which has been defined and stored in the memory by the manufacturer.

User message (text) - Information on the text display (text - max. length 64 characters each) assigned, during the programming process, to line elements or conventional lines and used by users to identify their location.

Quiescent (detection) mode - An operating condition in which the control panel or terminal are supplied from an electric energy source meeting defined requirements and in which no other operation mode is signalled.

Alarm (fire) mode - An operating condition the control panel enters after receipt of information on a fire detection from warning devices.

Disablement mode - An operating condition in which the control panel's reception of signals and generation of alarms from any call points are intentionally disabled or the output from the control

panel and/or the transmission path to any fire alarm system elements which create the alarm installation are disabled.

Test mode - An operating condition in which the control panel signals that applicable functions are being checked.

Fault mode - A condition in which the control panel signals a fault in any element of the alarm installation or own circuits.

Technical alarm mode - An operating condition in which the control panel signals actuation of any supervised external devices or informs about the fire detectors service status.

2 DEVICE COMPLETENESS

Table 2.1 lists the set of equipment delivered together with the terminal; table 2.2 provides a list of additional equipment which may be installed in the terminal (ordered separately).

Table 2.1

Item	Description	Quantity (pcs)
1	TSR 4000 parallel indication terminal	1
2	ID-E305-001-GB Operation and Maintenance Documentation (OMD)	1
3	Warranty certificate	1
4	Terminal unit package	1

Table 2.2

Item	Description	Remarks
1	Battery 12 V / 7.2 Ah	2 pcs for terminal

3 TECHNICAL SPECIFICATIONS

Overall dimensions L x H x G	322,5 x 367,8 x 110 mm
Mass (without batteries)	< 6 kg
Ingress protection	IP 30
Operating temperature range	from - 5 °C to + 40 °C
Admissible operation relative humidity	80 % at + 40 °C
Transport temperature range	from - 25 °C to + 55 °C
Power supply voltage:	
- mains 50 Hz	230 V + 10 % - 15 %
- HITACHI HV7-12 type batteries (or equivalent)	2 x 12 V / 7 Ah
Maximum mains current consumption	< 80 VA
Battery current consumption in quiescent mode	< 100 mA
PKA non-potential supervised relay alarm output:	
- current load	1 A / 30 V
PKU non-potential relay fault output:	
- current load	1 A / 30 V
Potential supervised output:	
- current load	0.5 A
- output voltage in active status	24 V + 25 % - 15 %
- end-of-line resistor value	10 kΩ ± 5 %, 0.25 W
Alphanumeric LCD display	4 x 40 characters
Number of terminals interoperation with control panel	1...16

4 DESIGN DESCRIPTIONS

4.1 Mechanical design

The terminal is made in the form of a metal cabinet intended for wall mounting. On its door, which is also the terminal front side, signalling and handling elements are located. The door opening is possible after removing two fixing screws. A switch with a key cannot be used as a mechanical lock. Inside the cabinet at the bottom, some room for battery installation is provided.

The TSG-4000 terminal main controller board is mounted on the inner side of the door. The terminal back side is the place where glands are provided for introduction of the RS-485 bus installation wires and power supply cables, the TPZ-4000 board with power supply circuits, serial interface as well as PKA and PKU relay outputs and LS potential output, is located. A 35 mm slat is provided on the terminal top side in order to connect an optic fibre converter (in the case of optic fibre connection of the terminal with control panel).

4.2 Handling and signalling elements, access levels

The signalling and handling elements are placed on the terminal door, which is also called 'the front panel' in this document. In this place, among others, the following components are located: illuminating diodes, backlit indicator with 'FIRE' sign, switch with a key ('ignition'), membrane push buttons. A backlit alphanumeric LCD display, with 4 x 40 characters, is placed in the upper part of the front panel. Every signalling and handling element is provided with a text description. The signalling and handling elements arrangement is shown in Fig 4.2.1 and their descriptions are contained in p. 5.2.

Handling elements that enable configuration parameter change are placed inside the terminal on the TSG-4000 main controller board in a form of the **SW1** 8-section switch. Also a potentiometer to adjust the display contrast and the **RESET** push button are located there. On the terminal back wall

the TPZ-4000 board is mounted where a two-pole 230 V mains power supply switch and **ZW1...ZW6** configuration jumpers are provided.

A detailed description of the signalling and handling elements mounted on the TSG-4000 and TPZ-4000 boards is contained in p. 5.3.

In the TSR-4000 terminal, accessibility to the handling elements and particular functions is diversified and divided into four access levels.

The 1st access level is provided for persons who take first activities after a fire alarm or fault indication. At this level, the **ACKNOWLEDGEMENT, ALARM, FAULT, DISABLEMENT, TESTING, TECHNICAL ALARM** and **CURSORS** push buttons are active.

The 2nd access level is intended for the persons especially responsible for the premises security that are properly trained and authorised to operate the terminal. The access to the 2nd level is obtained by turning the key in the **PERSONNEL ACCESS LEVEL** switch to the horizontal position. Then, all handling elements located on the front panel are available.

The 3rd access level is designed for the personnel properly trained and authorised to change configuration data and perform maintenance works. Handling elements are accessible at the 3rd level after removing two fixing screws.

The 4th access level is provided for the persons trained and authorised by the manufacturer to change the factory (default) software and service the device.

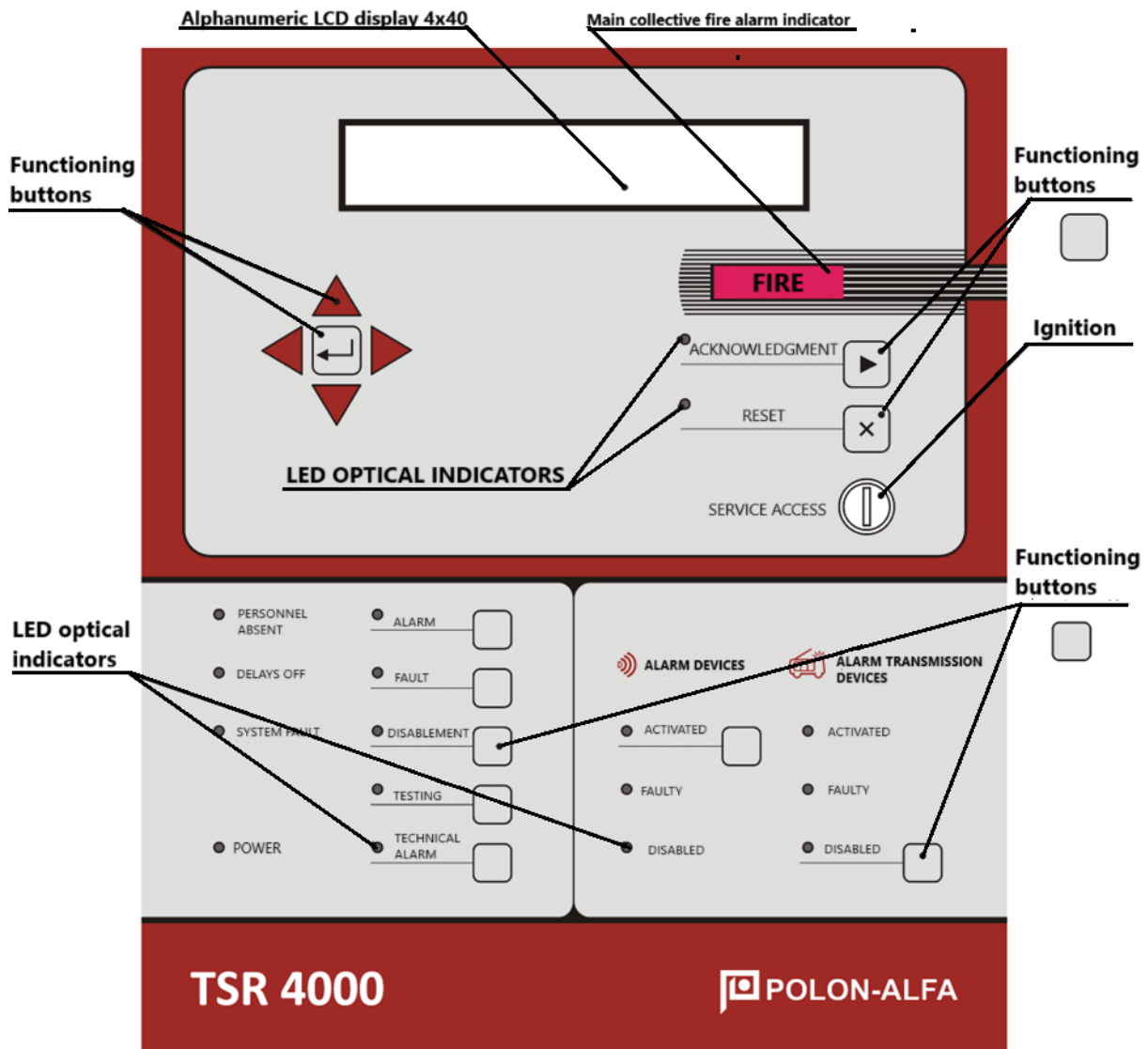

Fig. 4.2.1 TSR-4000 terminal front panel

5 FUNCTIONALITY DESCRIPTIONS

5.1 General descriptions

The TSR-4000 terminal is a device interoperating with the POLON 4000 system control panels (POLON 4100, POLON 4200 and POLON 4900) functioning as a remote information and servicing panel. All indications of the signalling elements reflect the control panel signalling elements status (with an exception of the POWER indicator), all messages on alarms, faults, disablements, test and technical alarms displayed on the terminal are the control panel's messages. The handling push buttons located on the terminal front panel are designed for those messages readout. Serial transmission circuits with the control panel, user communication system and power supply are monitored by a microprocessor-based system. The information received is analysed and makes possible to elaborate signals that control the front panel signalling and the terminal output circuits.

5.2 Front panel elements

5.2.1 Handling elements

Fig. 5.2.1. depicts the TSR-4000 terminal front panel handling elements arrangement.

- 1) **ACKNOWLEDGEMENT** - a push button to silence a signalling device: in the terminal LOCAL OPERATION MODE – a fire alarm; in the terminal REMOTE OPERATION MODE – a fault in the terminal, fire alarm, technical alarm or fault in the control panel (the operation available when the terminal is declared in the control panel as WITH ACCESS).
- 2) **RESET** - a push button to reset a fire alarm. The operation available at the 2nd access level in the terminal REMOTE OPERATION MODE and when the terminal is declared in the control panel as WITH ACCESS.
- 3) **PERSONNAL ACCESS LEVEL** – a switch (a lock with a key) to change the access level.
- 4) **ALARM** – a push button to get quick access to fire alarm messages.
- 5) **FAULT** – a push button of quick access to fault messages.
- 6) **DISABLEMENT** – a push button of quick access to disablement messages.
- 7) **TESTING** – a push button of quick access to test messages.
- 8) **TECHNICAL ALARM** – a push button of quick access to technical alarm messages.
- 9) **ACTIVATED (ALARM DEVICES)**
 - a) at the terminal REMOTE OPERATION MODE set – a push button to switch on/off:
 - outputs declared at the control panel as TYPE 1 outputs (to alarm devices);
 - terminal outputs programmed in VARIANT 3.

The operation available at the 2nd access level and when the terminal is declared in the control panel as WITH ACCESS.

- b) at the terminal LOCAL OPERATION MODE set – a push button to switch on/off the terminal outputs programmed as VARIANT 1.
- 10) **DISABLEMENT (ALARM TRANSMISSION DEVICES)** – a push button to switch on/off all the outputs declared as outputs to alarm transmission devices with an exception of the outputs permanently disabled at the control panel.

The operation available at the 2nd access level in the terminal REMOTE OPERATION MODE and when the terminal is declared in the control panel as WITH ACCESS.

- 11) **↵ ENTER** – a push button to enter the terminal main MENU (2nd access level) and to confirm the options selected from the MENU.
- 12) **⇒RIGHT CURSOR** – a push button to backlight the display.
- 13) **↓CURSOR DOWN** – a push button to rewind messages forward and to move in the MENU downwards.
- 14) **⇐LEFT CURSOR** – a push button to exit from the MENU, switch the display backlight off when the LCD shown the control panel date and time.
- 15) **↑CURSOR UP** – a push button to rewind messages back and to move in the MENU upwards.

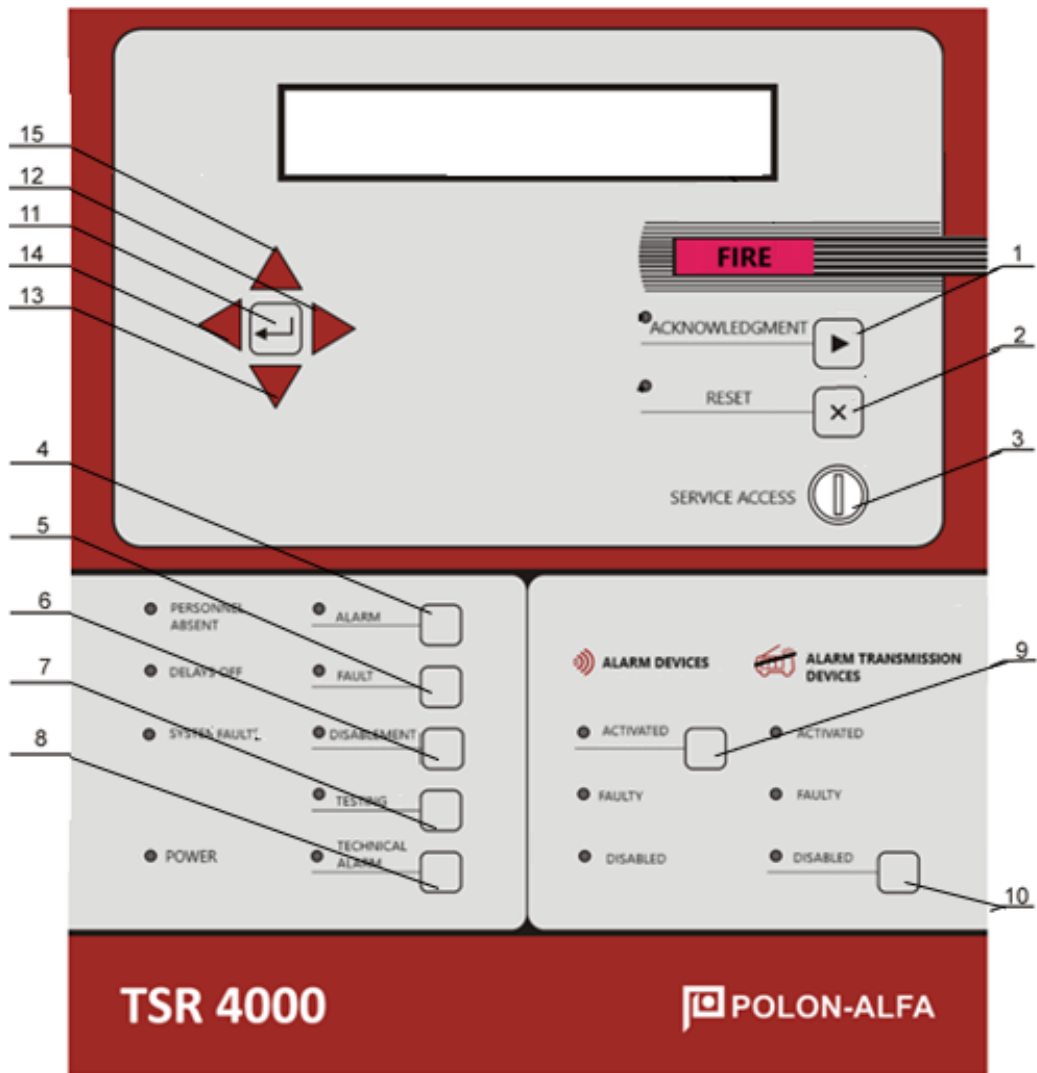

Fig. 5.2.1 Handling elements on TSR-4000 terminal front panel

5.2.2 Signalling elements

Fig. 5.2.2 shows the TSR-4000 terminal front panel signalling elements arrangement.

FIRE – a distinctive indicator of the fire alarm.

- 1) **ACKNOWLEDGEMENT** – an indicator of the acknowledgement active function.
- 2) **RESET** – an indicator of the reset active function.
- 3) **PERSONNEL ABSENT** – an indicator of the control panel Personnel Absent mode.
- 4) **DELAYS OFF** – an indicator of the control panel delays being switched off.
- 5) **SYSTEM FAULT** – an indicator of the control panel system fault.
- 6) **POWER** – an indicator of the terminal power supply:
 - steady light – the terminal powered from the mains; no faults,
 - pulsing light – any power supply fault revealed.
- 7) **ALARM** – the control panel collective indicator of a fire alarm:
 - steady light – the fire alarm acknowledged at the control panel,
 - pulsing light – the fire alarm not acknowledged at the control panel.
- 8) **FAULT** – the control panel and terminal collective indicator of a fault:
 - steady light – the fault acknowledged,
 - pulsing light – the fault not acknowledged.
- 9) **DISABLEMENT** – the control panel collective indicator of a disablement:
 - steady light – the disablement actuated.
- 10) **TESTING** – the control panel collective indicator of a test:
 - steady light – the testing actuated.
- 11) **TECHNICAL ALARM** – the control panel collective indicator of a technical alarm:
 - steady light – the technical alarm acknowledged,
 - pulsing light – the technical alarm not acknowledged.
- 12) **ACTIVATED (ALARM DEVICES)** – in the terminal REMOTE OPERATION MODE – an indicator of at least one alarm output activation in the control panel; in the terminal LOCAL OPERATION MODE – an indicator of at least one output activation in the terminal.
- 13) **FAULTY (ALARM DEVICES)** – in the terminal REMOTE OPERATION MODE – an indicator of a fault of output to alarm devices in the control panel; in the terminal LOCAL OPERATION MODE – an indicator of a fault of output in the terminal.
- 14) **DISABLED (ALARM DEVICES)** – an indicator of a disablement of outputs to alarm devices in the control panel:
 - steady light – all outputs declared as outputs to external devices are disabled (in the control panel),
 - pulsing light – some outputs declared as outputs to external devices are disabled (in the control panel).
- 15) **ACTIVATED (ALARM TRANSMISSION DEVICES)** – an indicator of at least one alarm transmission output activation in the control panel.
- 16) **FAULTY (ALARM TRANSMISSION DEVICES)** – an indicator of a fault of outputs to alarm transmission devices in the control panel.
- 17) **DISABLED (ALARM TRANSMISSION DEVICES)** – an indicator of a disablement of output to alarm transmission devices in the control panel:
 - steady light – all outputs declared as outputs to alarm transmission devices are disabled (in the control panel),
 - pulsing light – some outputs declared as outputs to alarm transmission devices are disabled (in the control panel).

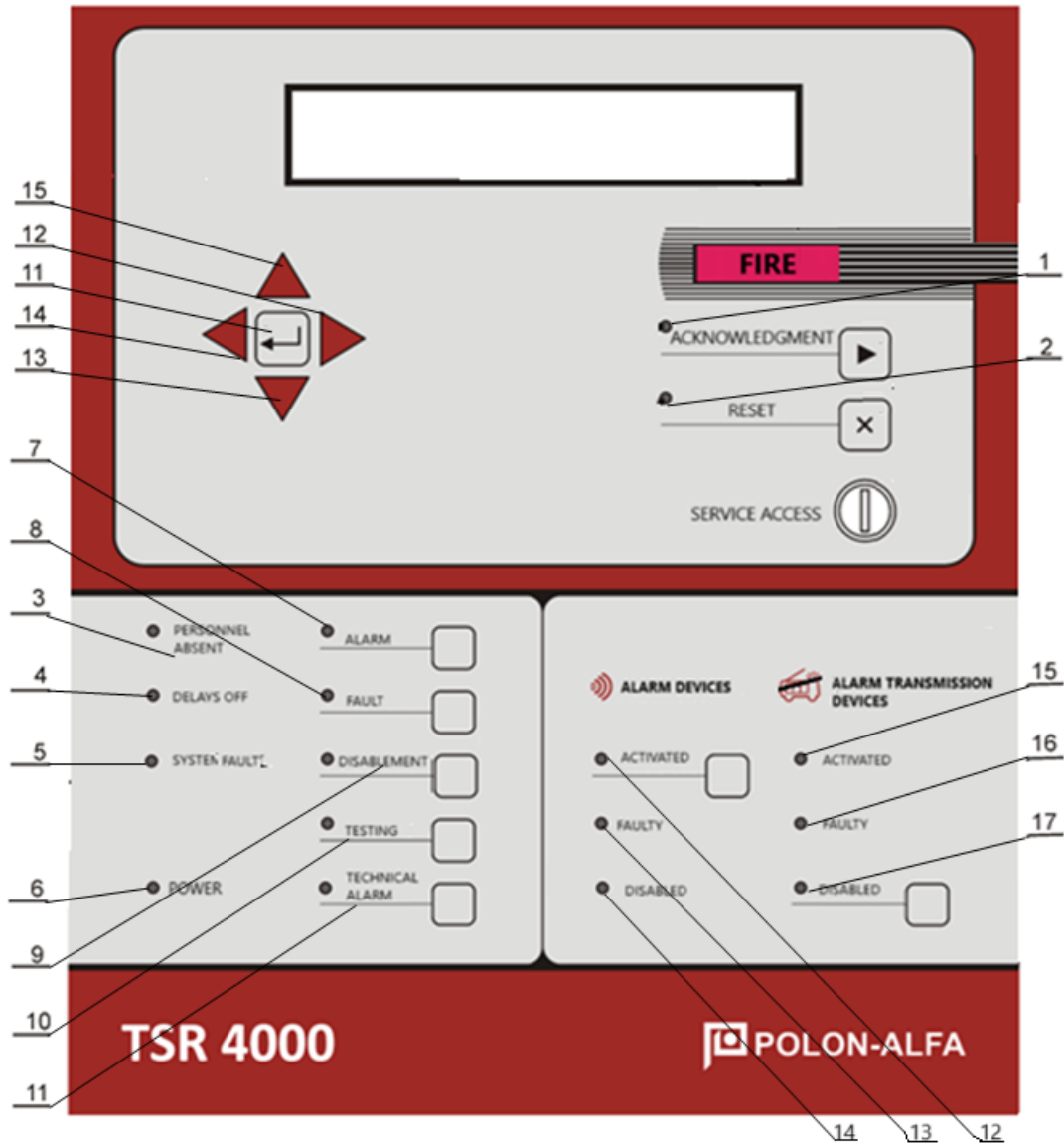

Fig. 5.2.2 TSR-4000 terminal front panel signalling elements

5.3 Handling elements inside terminal

5.3.1 TSG-4000 main controller board

Fig. 5.3.1 depicts the TSG-4000 main controller board outlook after the door opening. The following elements are accessible: **SW1** eight-position switch with K1...K8 keys, potentiometer marked as **CONTRAST** and **RESET** push button (pressing the button results in the terminal main controller restart).

Terminal number

The **SW1** switch K1...K5 keys are provided to allocate the terminal number using binary code. Every key possesses an appropriate W_n weight determined by its number. The terminal number can be expressed with the following formula:

$$\text{TERMINAL NO.} = W_1 * 1 + W_2 * 2 + W_3 * 4 + W_4 * 8 + W_5 * 16$$

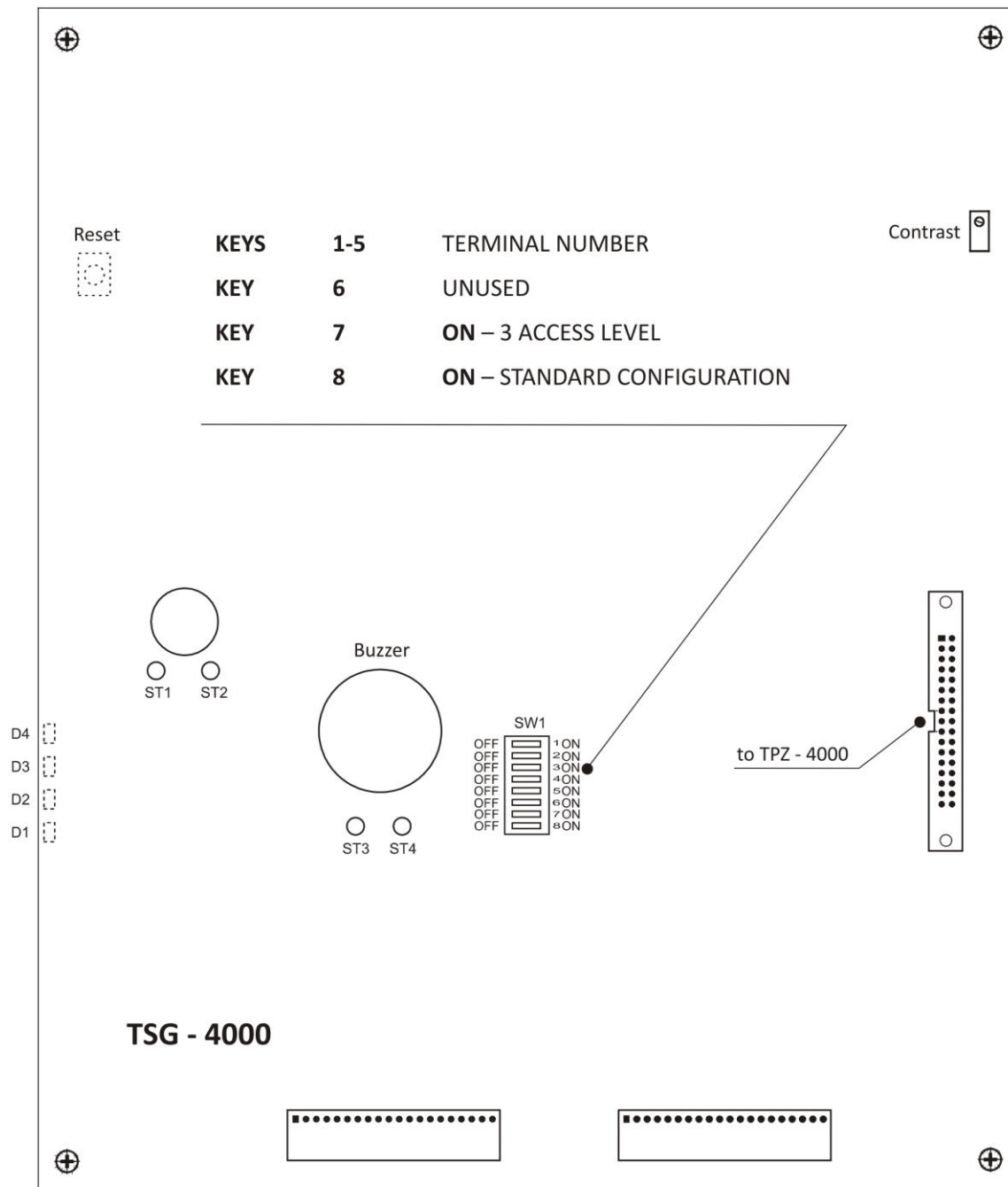

Fig. 5.3.1 TSG-4000 main controller board outlook (after door opening)

5.3.2 TPZ-4000 power supply, serial interfaces and outputs board

In Fig. 5.3.2a and Fig. 5.3.2b the TPZ-4000 power supply, serial interfaces and outputs board are shown. The following handling and configuration elements are available: **ZW1...ZW6** jumpers, SW-CONNECT BATTERY push button, P potentiometer, mains switch. Also the below listed fuses are mounted on the board:

- BS / 500 mA	primary terminal protection,
- B1 / 2 A	battery cluster circuit protection,
- B2 / 2 A	30 V converter protection,
- B3 / 630 mA	signalling line protection.

Additionally, other connectors were located on the TPZ-4000 board: all terminal blocks to connect external wire installations (mains power supply, output and potential outputs wires), the RS-485 serial interface contacts and a connector of the terminal operation voltage 24 V + 25 % - 15 % to supply the optic fibre converters.

End-of-line resistor

ZW1, ZW5 - RS-485 bus end-of-line resistor jumpers:

position 1 - 2	120 Ω resistor switched on,
position 2 - 3	lack of end-of-line resistor.

Detailed description of the end-of-line resistor role is contained in p. 7.3.

Relay monitoring

ZW2 – PKA alarm relay hardware monitoring jumper:

position 1 - 2	no monitoring,
position 2 - 3	relay output hardware monitoring.

In case relay output monitoring is programmed but the ZW2 jumper is placed in 1 - 2 position, the terminal indicates the relay output fault. In case relay monitoring is program disabled, the ZW2 position is irrelevant. Detailed description of the relay output function is contained in p. 5.8.2.

Earth fault monitoring

ZW3 - earth fault monitoring jumper:

position 1	earth fault monitoring,
position 4	no monitoring.

After putting the jumper in position 1, the terminal monitors whether the terminal power supply is not grounded; in the case of earth fault, a fault is indicated in the terminal.

RS-485 converter

ZW4 – optic fibre converter jumper:

position 1 - 2	RS-485 bus optic fibre connection,
position 2 - 3	RS-485 bus wire (copper twisted conductor) connection.

RS-485 redundancy

ZW6 - RS-485 bus redundancy jumper:

position 1 - 2	no redundancy (transmission 1 channel),
----------------	---

position 2 - 3

redundancy (transmission 2 channels).

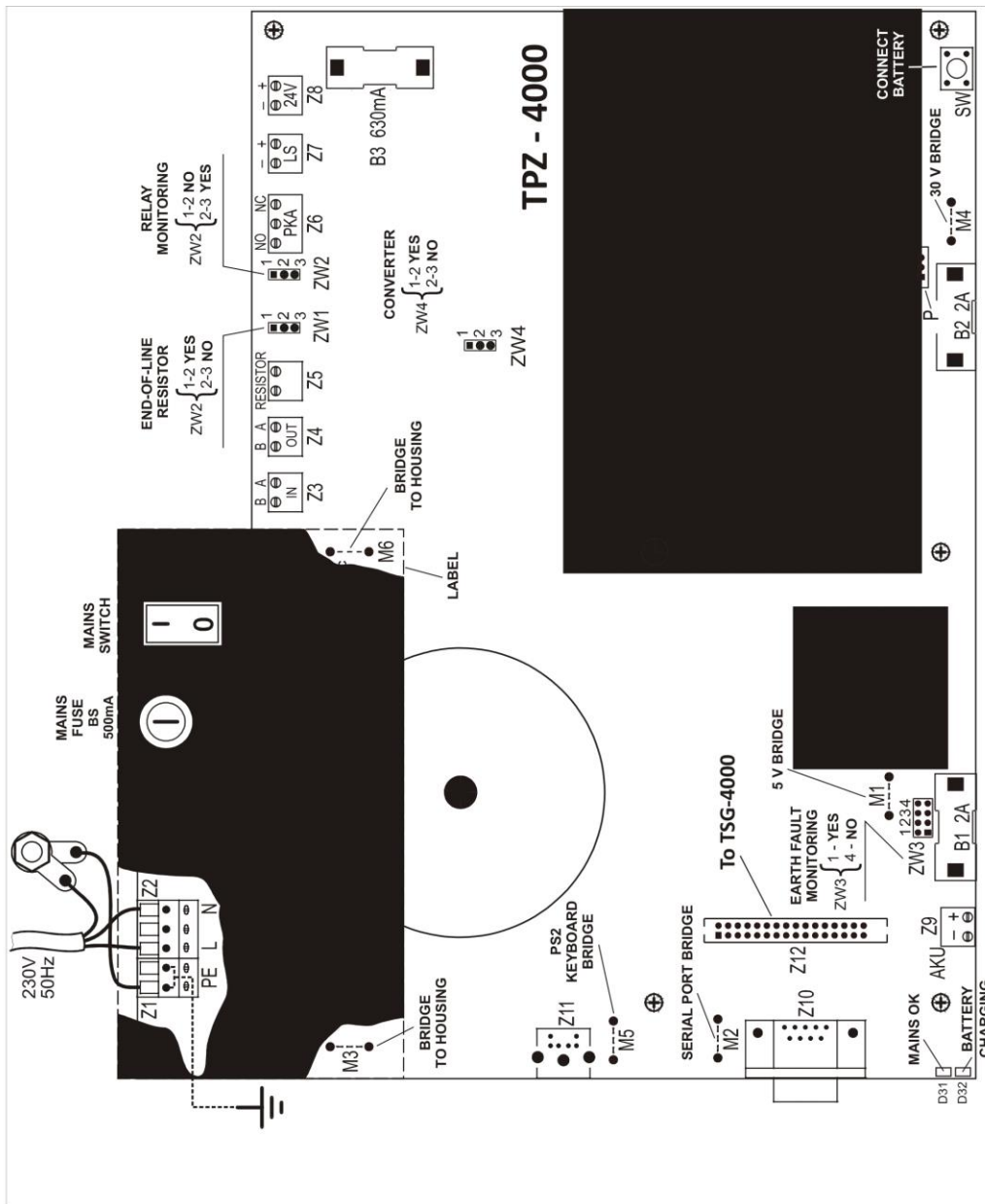

Fig. 5.3.2a TPZ-4000 power supply, serial interfaces and outputs board

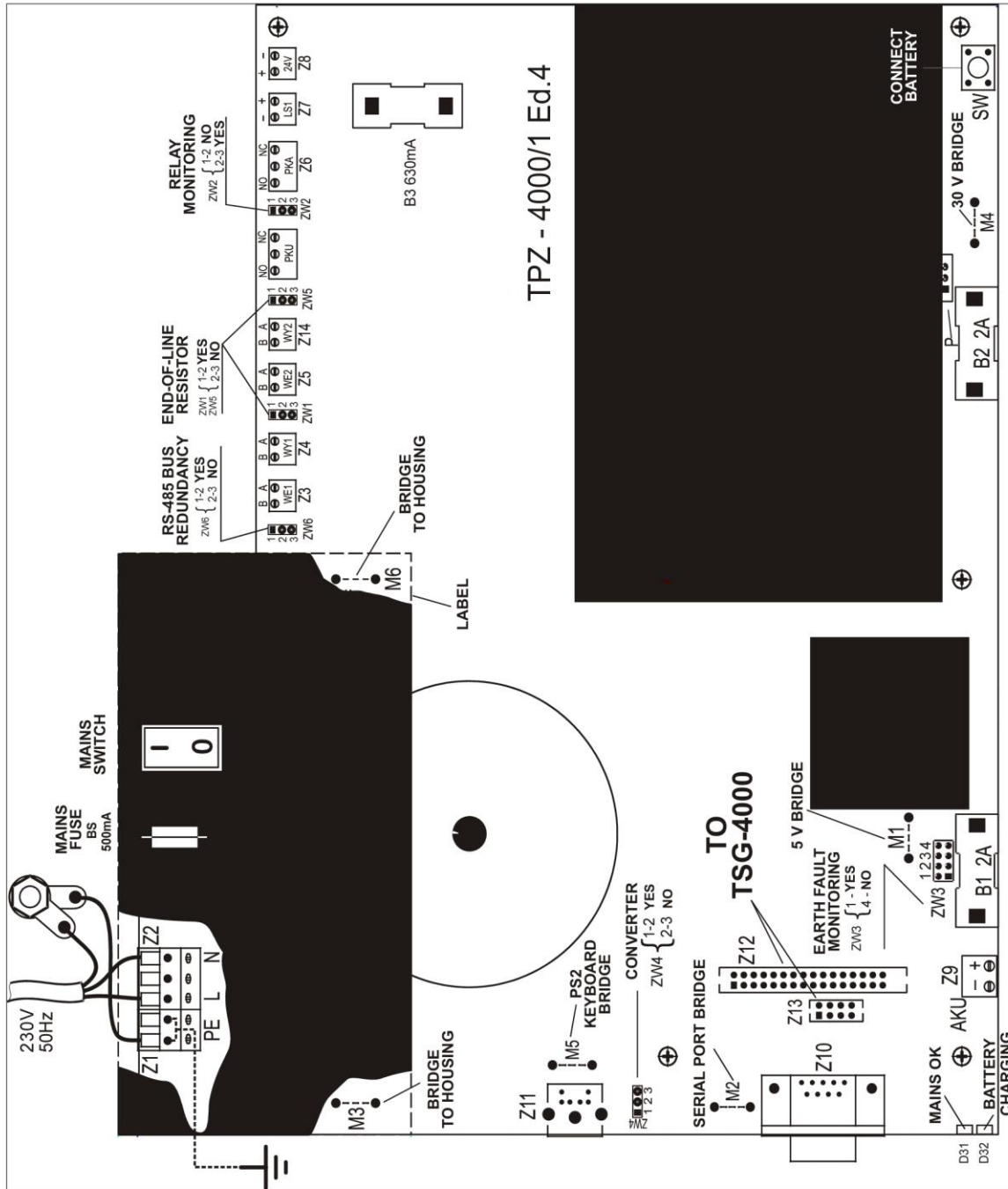

Fig. 5.3.2b TPZ-4000 power supply, serial interfaces and outputs board Ed.4

5.4 Alphanumeric LCD display

The TSR-4000 terminal is furnished with an alphanumeric display 4 x 40 (4 lines 40 characters each). Its main function is to display messages on a status of the control panel which it is connected to. In the quiescent mode the terminal shows on the display the same date and time as that in the control panel, current access level and the terminal number. The display is equipped with backlighting which is switched off in the quiescent mode. Any operation leading to a message readout actuates the terminal automatic backlighting. After two minutes from the latest operation, the backlighting is automatically switched off and the device resumes the date and time displaying. The exception is the

fire alarm mode and 'NO CONNECTION WITH CONTROL PANEL' fault; those conditions are displayed without any user operation.

5.5 Terminal operation modes

The terminal can work in two modes of handling, alarming and outputs activation:

- a) **REMOTE** - the terminal handling and outputs activation depend on the control panel only,
- b) **LOCAL** - the terminal handling and control depend on the control panel and own configuration settings.

5.5.1 REMOTE operation mode

In the remote operation mode signalling optical elements and the terminal acoustic signalling device reflect the control panel signalling elements status; the only exception is the POWER indicator which signals the terminal power supply condition.

In case the terminal is declared in the control panel as WITH ACCESS, it is possible to acknowledge (thereby also silence acoustic signalling) from the terminal level with the **ACKNOWLEDGEMENT** push button at the 1st access level:

- a fire alarm,
- a fault (also non-maskable) in the control panel,
- a technical alarm in the control panel.

In case the terminal is declared in the control panel as WITH ACCESS, it is possible to reset from the terminal level at the 2nd access level (the switch key in the horizontal position) a fire alarm in the control panel, using the **RESET** push button.

The terminal PK relay outputs and LS potential outputs are activated during a fire alarm, if they are programmed in VARIANT 3 and the **ACTIVATED** indicator is lit in the control panel ALARM DEVICES field (at least one relay output or potential output declared as TYPE 1). If the terminal is declared in the control panel as WITH ACCESS, it is possible – after obtaining the 2nd access level in the terminal (the switch key in the horizontal position) – to switch off the relay output and potential output in the terminal and the outputs declared in the control panel as outputs to fire alarm devices using the **ACTIVATED** push button.

The push buttons applications and available functions in the REMOTE operation mode are listed in Table 5.5.1.

Table 5.5.1 REMOTE operation mode

PUSH BUTTON FUNCTION	REMOTE OPERATION MODE					
	TERMINAL DECLARED IN CONTROL PANEL AS					
	WITH ACCESS			WITHOUT ACCESS		
	FUNCTION	ACCESS LEVEL	ACOUST. SIGN. DEV. SILENCING	FUNCTION	ACCESS LEVEL	ACOUST. SIGN. DEV. SILENCING
ACKNOWLEDGEMENT OF						
ALARM	+	1	YES	-	X	NO
FAULT	+	1	YES	-	X	NO
NON-MASK. FAULT	+	1	YES	-	X	NO
TECH. ALARM	+	1	YES	-	X	NO
RESET						

PUSH BUTTON FUNCTION	REMOTE OPERATION MODE					
	TERMINAL DECLARED IN CONTROL PANEL AS					
	WITH ACCESS			WITHOUT ACCESS		
	FUNCTION	ACCESS LEVEL	ACOUST. SIGN. DEV. SILENCING	FUNCTION	ACCESS LEVEL	ACOUST. SIGN. DEV. SILENCING
ALARM	+	2	ND	-	X	ND
ACTIVATED	+	2	ND	-	X	ND
DISABLED	+	2	ND	-	X	ND
ALARM	+	1	ND	+	1	ND
FAULT	+	1	ND	+	1	ND
DISABLEMENT	+	1	ND	+	1	ND
TESTING	+	1	ND	+	1	ND
TECH. ALARM	+	1	ND	+	1	ND

+: available function, -: unavailable function, **ND**: not applicable, **X**: irrelevant

5.5.2 LOCAL operation mode

In the local operation mode, the terminal signalling elements reflect the control panel signalling elements status; with exception of several indicators: **POWER** – which indicates the terminal power supply; **ACTIVATED** (in the ALARM DEVICES field) – which indicates the terminal relay or potential output activation (depending on the actuation variant programmed); **FAULTY** (in the ALARM DEVICES field) – which indicates the terminal relay or potential output fault.

it is possible to acknowledge from the terminal level with the **ACKNOWLEDGEMENT** push button at the 1st access level:

- a fire alarm locally in the terminal (acoustic signalling silencing),
- the terminal own fault (acoustic signalling silencing).

It is impossible to acknowledge from the terminal level a fire alarm in the control panel, a fault (also a non-maskable fault) in the control panel, a technical alarm in the control panel. It is also impossible to reset a fire alarm in the control panel (the terminal will signal the fire alarm mode until its reset in the control panel).

If a relay or potential output is programmed as VARIANT 1, the output is activated with any new fire alarm; its disablement or re-enablement is possible only using the **ACTIVATED** push button after obtaining the 2nd access level in the terminal (the switch key in the horizontal position).

In case a relay or potential output is programmed as VARIANT 2, the output is activated with any new fire alarm. After acknowledgement with the **ACKNOWLEDGEMENT** push button, the previously activated output is disabled in the terminal.

If a relay or potential output is programmed as VARIANT 3, the output status depends on the status of the **ACTIVATED** indicator in the **ALARM DEVICES** field. If the diode is lit, the relay or potential output is switched over and are active. It is no possibility to disable those outputs from the terminal level.

The push buttons applications and available functions in the LOCAL operation mode are listed in Table 5.5.2.

Table 5.5.2 LOCAL operation mode

PUSH BUTTON FUNCTION	LOCAL OPERATION MODE					
	TERMINAL DECLARED IN CONTROL PANEL AS					
	WITH ACCESS			WITHOUT ACCESS		
	FUNCTION	ACCESS LEVEL	ACOUST. SIGN. DEV. SILENCING	FUNCTION	ACCESS LEVEL	ACOUST. SIGN. DEV. SILENCING
ACKNOWLEDGEMENT OF						
ALARM	+ ¹⁾	1 ¹⁾	YES ¹⁾	+ ¹⁾	1 ¹⁾	YES ¹⁾
FAULT	+ ²⁾	1 ²⁾	YES ²⁾	+ ²⁾	1 ²⁾	YES ²⁾
NON-MASK. FAULT	-	X	ND	-	X	ND
TECH. ALARM	-	X	ND	-	X	ND
RESET OF						
ALARM	-	X	ND	-	X	ND
ACTIVATED	+	2	ND	+	2	ND
DISABLED	-	X	ND	-	X	ND
ALARM	+	1	ND	+	1	ND
FAULT	+	1	ND	+	1	ND
DISABLEMENT	+	1	ND	+	1	ND
TESTING	+	1	ND	+	1	ND
TECH. ALARM	+	1	ND	+	1	ND

+: available function, -: unavailable function, **ND**: not applicable, **X**: irrelevant

- 1) Alarm acknowledgement (acoustic signalling device silencing) locally only in the terminal.
- 2) Acknowledgement (acoustic signalling device silencing) of the terminal own fault.

In the REMOTE operation mode, the buttons **ACKNOWLEDGEMENT**, **RESET**, **ACTIVATED** and **DISABLED** have impact on the control panel and terminal signalling and outputs status.

In the LOCAL operation mode, the buttons **ACKNOWLEDGEMENT**, **ACTIVATED** have impact on only the terminal signalling and outputs status.

5.5.3. Operation mode programming

In order to program the terminal operation, it is necessary to exit the main window (date and time on the display); after obtaining the 3rd access level in the terminal (the switch key in the horizontal position and the TSG-4000 K7 key in ON position) it is necessary to press ENTER (↵) and the following windows will be displayed:

5.6.2 Alarming

The terminal signals PRELIMINARY ALARM, ALARM I (1st stage alarm) or ALARM II (2nd stage alarm) depending on the alarming variants being programmed for the control panel particular zones.

The PRELIMINARY ALARM is indicated by the flashing red **ALARM** indicator. The alarming zones messages are shown on the display. Moreover, information about the number of alarming zones and the number of zones undisclosed (due to limited capacity) is displayed. Additionally, in case the terminal is linked with a framework control panel, the alarming control panel number is displayed. The preliminary alarm is an internal alarm of the control panel and can be acknowledged with the **ACKNOWLEDGEMENT** push button and subsequently reset with the **RESET** push button (if the terminal works in the REMOTE OPERATION MODE).

Note – The preliminary alarm can be changed into a fire alarm or automatically reset by the control panel according to appropriate algorithms resulting from the control panel zone alarm variants.

The alarm mode is signalled by flashes of the red **FIRE** indicator and the **ALARM** diode. The alarming zones messages appear on the display. Information about the number of alarming zones and the number of zones undisclosed (due to limited capacity) is displayed. Apart from that, information on elapsing time (TRANSMISSION) after which the control panel outputs to alarm transmission (monitoring) devices will be activated. Moreover, if the terminal is linked with a framework control panel, the alarming control panel number is displayed.

The ALARM I is an internal alarm and requires the attending personnel presence confirmation and the alarm acknowledgement with the **ACKNOWLEDGEMENT** push button (during the T1 time) as well as the danger recognition in the premises (during the T2 time). The alarm can be acknowledged from the terminal level if this device is declared at the control panel as WITH ACCESS. In the case of the lack of appropriate reaction to the 1st stage alarm by the personnel on duty, the ALARM II is evoked. The ALARM II can be preceded by a 1st stage alarm or it is generated immediately, depending on an alarm variant programmed for a particular object zone or the control panel operation mode (PERSONNEL ABSENT).

In the case of higher number of alarming zones, the display shows the first and the latest alarm. Using the **ALARM** push button and ↓↑ cursors, it is possible to review undisclosed alarms. The review concerns all alarming zone with the exception of the first one that is permanently displayed in the first lines of the alarm window. Additionally, in case the terminal is linked with a framework control panel, the alarming control panel number is displayed. After 30 seconds from the latest operation, the terminal automatically displays the first and the latest alarm.

Simultaneously with the optical signalling during the fire alarm, also a steady acoustic sound is generated in the terminal which can be silenced by pressing the **ACKNOWLEDGEMENT** backlit push button if the terminal works in the LOCAL OPERATION MODE or in the REMOTE OPERATION MODE under condition that it is declared at the control panel as WITH ACCESS.

IN REMOTE OPERATION MODE

If the red diode **ACTIIVTED** in the **ALARM DEVICES** field is lit, relay outputs and potential outputs are switched over and they are in an active mode if they are programmed in VARIANT 3. In case the terminal is declared at the control panel as WITH ACCESS, then, after obtaining the 2nd access level in the terminal (the switch key in the horizontal position), it is possible to disable (with the **DISABLEMENT** push button) the outputs programmed at the control panel as outputs to fire alarm devices. Transmission If the red diode **ACTIVATED** in the **ALARM TRANSMISSION DEVICES** field is lit, then, after obtaining the 2nd access level in the terminal (the switch key in the horizontal position), it is possible to disable (with the **DISABLEMENT** push button) the outputs programmed at the control panel as outputs to alarm transmission devices.

In case the terminal is declared at the control panel as WITH ACCESS, after obtaining the 2nd access level in the terminal (the switch key in the horizontal position), it is possible to reset a fire alarm indication with the backlit **RESET** push button.

IN LOCAL OPERATION MODE

The relay outputs actuation and potential outputs actuation are dependable on the actuation variant that is assigned to this output. In case the relay of potential output is programmed in VARIANT 1, then the output is actuated by any new fire alarm; its disablement or re-enablement is possible only using the **ACTIVATED** push button after obtaining the 2nd access level in the terminal (the switch key in the horizontal position).

In case the relay or potential output is programmed in VARIANT 2, the output is activated by any new fire alarm. After acknowledgement with the **ACKNOWLEDGEMENT** push button, the previously activated output is disabled in the terminal.

If the relay or potential output is programmed in VARIANT 3, the output status relies on the status of the **ACTIVATED** indicator in the **ALARM DEVICES** field in the control panel. If the diode is lit, the relay or potential output is switched over and are active. It is no possibility to disable those outputs from the terminal level.

Exemplary display messages in the alarm mode are presented below:

									!!!	FIRE	ALARMS	!!!																								
Q	-	T	Y	:	0	0	1		H	I	D	D	E	N	:	0	0		T	R	A	N	S	M	I	S	S	I	O	N	:	0	0	:	3	0
0	0	1			S	T	A	N	D	A	R	D		M	E	S	S	A	G	E																
					D	E	T	E	C	T	I	O	N		Z	O	N	E		N	O	.														

									!!!	FIRE	ALARMS	!!!																										
Q	-	T	Y	:	0	0	1		H	I	D	D	E	N	:	0	0																					
0	0	1			S	T	A	N	D	A	R	D		M	E	S	S	A	G	E																		
					C	0	7		D	E	T	E	C	T	I	O	N		Z	O	N	E		N	O	.												

0	0	1			S	T	A	N	D	A	R	D		M	E	S	S	A	G	E																		Q	T	Y					
					C	0	7		D	E	T	E	C	T	I	O	N		Z	O	N	E		N	O	.														0	0	5			
					0	0	5		S	T	A	N	D	A	R	D		M	E	S	S	A	G	E																	H	I	D		
					C	0	3		D	E	T	E	C	T	I	O	N		Z	O	N	E		N	O	.																	0	0	3

where:

xxx e.g. 001 – means a consecutive alarm number,

Cxx e.g. C07 – means the number of the alarming control panel,

QTY – means the total number of all alarms,

HID – means the number of hidden (undisclosed) alarms (not displayed on the LCD).

!!! FIRE ALARMS !!!											
- - - - -											
QUANTITY: 005						HIDDEN: 003					
TRANSMISSION: 00:59											

!!! FIRE ALARMS !!!											
- - - - -											
QUANTITY: 005						HIDDEN: 003					
2ND STAGE ALARM											

Preliminary alarm window:

!!! PRELIMINARY ALARMS !!!											
QUANTITY: 001						HIDDEN: 000					
001 STANDARD MESSAGE											
DETECTION ZONE NO. 1											

From the terminal level it is possible to review the elements evoking an alarm in the interoperating control panel. For this purpose, it is necessary to exit the main window (the date and time on the LCD), press the **ENTER** (↵) push button after obtaining the 2nd access level in the terminal (the switch key in the horizontal position), and – using the ↓↑ cursors – move to the below shown window:

- MENU -											
EVENT / ALARM MEMORY											↵
SYSTEM STATUS READOUT											↵
TERMINAL TEST											↵

Then, the SYSTEM STATUS READOUT option should be chosen, the following window will be displayed:

- MENU -											
ALARMING ELEMENTS											↵
TERMINAL INTEROPERATION WITH C. PANEL											↵
SOFTWARE VERSION											↵

and after that the ALARMING ELEMENTS should be selected. Then, in case any element signals the alarm mode, the following window will appear on the display, which contains:

- L**: - detection line number: 1...8 (POLON 4900), 1...4 (POLON 4200), or 1...2 (POLON 4100),
- E**: - alarming element number: 1...127 (POLON 4900) or 1...64 (POLON 4200, POLON 4100),
- S**: - number of the zone to which the element is assigned: 1...1024 (POLON 4900), 1...256 (POLON 4200) or 1...128 (POLON 4100),
- W**: - alarm variant of the zone to which the element is assigned,
- G**: - group (A or B),
- T**: - the alarming element operation mode,
- NR**: - 12-digit element serial number.

Besides, the alarming element type is shown (e.g. DOR) and a message of the zone to which the element is assigned. In case some elements indicate the alarm mode, it is possible to rewind them using the ↵ cursors.

An exemplary alarming element display:

ALARMING ELEMENTS															
L:		4	DOR	W: 02	G: A	T: 01	NR: 0210	E A 001823							
E:	127		STANDARD	MESSAGE											
S:	1000		DETECTION	ZONE NO.	256										

In case no element signals a fire alarm in the control panel the following message is displayed:

- ALARMING ELEMENTS -															
NO ALARMING ELEMENTS															

5.6.3 Fault

Any revealed fault is signalled optically and acoustically. Optically it is indicated by a flashing light of the collective yellow **FAULT** diode. In the case of a system fault in the control panel, additionally the yellow **FAULT** diode should be lit in the terminal and an acoustic interrupted sound of constant frequency should be generated in the terminal REMOTE OPERATION MODE. In the case of the terminal LOCAL OPERATION MODE, the acoustic signalling switches on when the terminal own fault occurs. The optical and acoustical signalling switches off automatically when the fault is removed. After pressing the **ACKNOWLEDGEMENT** backlit push button, the acoustical signalling is switched off. After the acknowledgement, the **FAULT** indicator is lit with a steady light.

Faults displayed by the terminal can be divided into three categories:

- CONTROL PANEL** – faults of detection lines, elements interoperating with the control panel and faults occurring inside the control panel,
- NON-MASKABLE** – faults arising in the monitoring circuits of LK monitoring lines or EKS-4001 monitoring and controlling elements of the POLON 4900, POLON 4200 or POLON 4100 control panels,
- TERMINAL** - faults occurring inside the terminal.

It is possible to review the faults currently revealed using the **FAULT** push button at the 1st access level.

After pressing the ENTER (↵) button, the rest of the message is revealed:

J	U	M	P	(>)	:	1	0			-	E	V	E	N	T	M	E	M	O	R	Y	-	Q	U	A	N	T	I	T	Y	:	1	8	9	5	
0	6	0		D	E	T	E	C	T	I	O	N		Z	O	N	E		N	O	.		2	5	6													
2	/	2		2	0	0	3	-	1	2	-	3	1	/	0	9	:	1	5	:	5	7																
.	.	1																																				

In case **ALARM MEMORY** option is chosen, a window is displayed in which the number of alarms stored in the memory is shown in the upper right corner, and in the upper left corner the JUMP parameter is presented (indicating how many messages will be scrolled during a review), which can be changed with the ⇨right cursor from 1 to 10 or vice versa, the alarm number in the memory is displayed as well as the alarm message. The cursor ↓↑ push buttons are used to rewind subsequent messages

An alarm memory window example:

J	U	M	P	(>)	:	1	0			-	A	L	A	R	M	M	E	M	O	R	Y	-	Q	U	A	N	T	I	T	Y	:	9	9	9	9	
				-	-	-	-	9	9	9	9	-	-	-	-																							
				Z	O	N	E	:	1	0	2	4																										
				2	0	0	7	-	1	1	-	0	5	/	1	1	:	2	3	:	5	4																

5.8 Terminal outputs

5.8.1 PKA non-potential monitored relay alarm output

A non-potential monitored relay output can be monitored (in the non-actuation mode) as to a short circuit or break in the relay output line. A non-potential relay output will be monitored if – during the relay programming – the line continuity monitoring is declared.

The output is properly monitored if in the quiescent mode external devices connected to this output are power supplied by voltage from 6...30 V range and the **ZW2** jumper (TPZ-4000 board) is placed in the 2 - 3 YES position. In the event of a voltage outage on the relay output NO clamp, the terminal indicates an output fault. A relay output monitoring can be disabled when the line continuity monitoring is undeclared.

An exemplary solution of a relay output monitoring is shown in Fig. 5.8.1.

Note – The line continuity monitoring circuit draws ca. 0.5 mA current from the external device connected to the relay output. If current consumption from the external device is unwelcome, then the line continuity monitoring circuit can be software disabled by declaring lack of the output monitoring and hardware blocked by placing the ZW2 jumper in the 1 - 2 NO position.

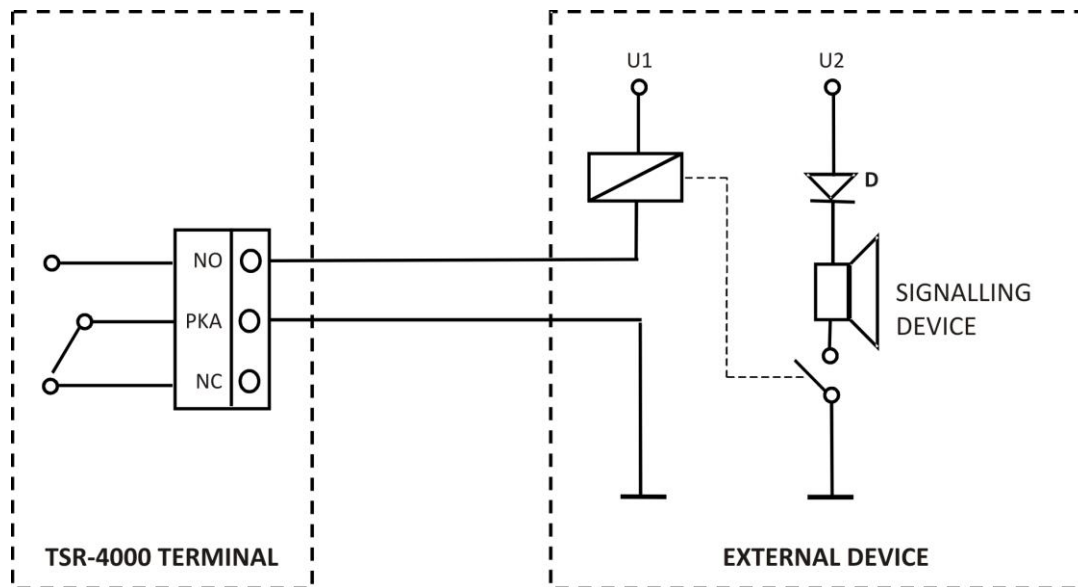

Fig. 5.8.1 Exemplary solution of relay output monitoring

5.8.2 PKU non-potential relay fault output

The PKU fault output has a reverse notation in comparison with the alarm relay. Its normal mode (no fault) is the relay **C-NO** position. Any fault, both in the control panel or in the terminal (including the terminal shutdown) is indicated by the relay **NC-C** position.

5.8.3 LS potential monitored output

A potential output enables line resistance monitoring during the quiescent mode; in order to disclose its fault, it is executed with the output voltage reverse polarization. In the quiescent mode, the line resistance (together with the connecting conductors resistance) amounts to 2.7 k Ω - 16 k Ω . In case the resistance does not fit the range mentioned, such a condition is treated as a fault and accordingly signalled in the terminal. After the output actuation, the output voltage polarization is change to positive. The line should be terminated with a 10 Ω end-of-line resistor. An exemplary use of a potential line to control external alarm devices is shown in Fig. 5.8.2.

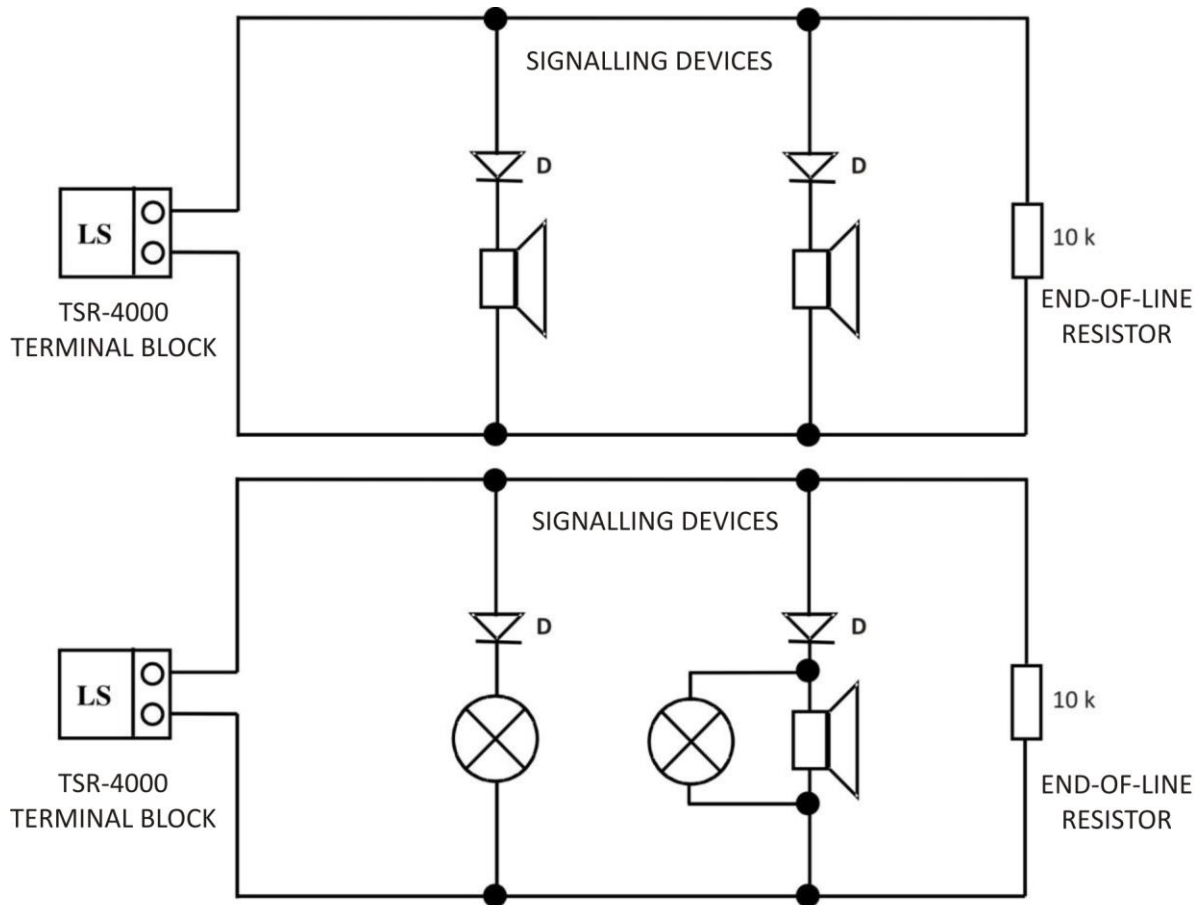

Fig. 5.8.2 Exemplary connection of signalling devices to potential output

Note – In case the output is unused, a 10 kΩ end-of-line resistor should be placed on the potential output clamps. If the unused output is not terminated with the end-of-line resistor and is programmed in VARIANT 1, 2 or 3, then the terminal indicates the signalling line fault. Circuits of external devices controlled from the potential output should be galvanically isolated from the terminal internal operation voltage.

5.8.4 Terminal outputs programming

Relay and potential outputs can be programmed pursuantly to the following variants:

- VARIANT 0 – undeclared (inactive) output; REMOTE and LOCAL OPERATION MODE,
- VARIANT 1 – an output activated with any new fire alarm; disablement and re-enablement with the ACTIVATED push button located in the ALARM DEVICES field at the 2nd access level; LOCAL OPERATION MODE,
- VARIANT 2 - an output activated with any new fire alarm; disablement with the ACKNOWLEDGEMENT push button at the 1st access level; LOCAL OPERATION MODE,
- VARIANT 3 – output activation dependence on a status of **ACTIVATED** diode located in the **ALARM DEVICES** field in the control panel. If it is lit, relay and potential outputs are switched over and they are in an active mode. In the LOCAL OPERATION MODE it is impossible to disable those outputs from the terminal level. In the REMOTE OPERATION MODE, if the terminal is declared as WITH ACCESS – after obtaining the 2nd access level in the terminal (the switch key in the horizontal position) – it is possible (using the **ACTIVATED** press button) to disable the relay and potential outputs in the terminal and the outputs programmed in the control panel as outputs to fire alarm devices.

Table 5.8.3.1 Outputs variants in REMOTE OPERATION MODE

REMOTE OPERATION MODE	
VARIANT	ACTUATION CRITERION
0	Inactive output
3	Output actuation dependent on the ACTIVATED indicator in the control panel

Table 5.8.3.2 Outputs variants in LOCAL OPERATION MODE

LOCAL OPERATION MODE	
VARIANT	ACTUATION CRITERION
0	Inactive output
1	Any new 1 st stage or 2 nd stage fire alarm in the control panel or 'manual activation with the ACTIVATED push button at the 2 nd access level
2	Any new 1 st stage or 2 nd stage fire alarm until acknowledgement
3	Output actuation dependent on the ACTIVATED indicator in the control panel

In order to program the terminal relay and potential output, it is necessary to exit the main window (the date and time on the LCD), after obtaining the 3rd access level in the terminal (the switch key in the horizontal position and the K7 key on TSG-4000 in ON position) it is necessary to press the **ENTER** (↵) push button – the below shown window will appear:

- MENU -																
TERMINAL	CONFIGURATION	READOUT														↵
TERMINAL	CONFIGURATION														↵	
ALARMING	CONFIGURATION														↵	

The **TERMINAL CONFIGURATION** option should be chosen the following window will be displayed:

- TERMINAL CONFIGURATION -															
OPERATION	MODE														↵
OUTPUTS														↵	
SERIAL	PORT														↵

After choosing the **EXIT** option, the window as below will appear:

- OUTPUTS CONFIGURATION -															
PK	OUTPUT:	VARIANT - 0	↵	MONITORING:	NO	↵									
LS	OUTPUT:	VARIANT - 0	↵	MONITORING:	NO										
* CONFIGURATION SAVING *															

When the tag is placed in the second line at a relay VARIANT selection with the ⬇⬆ cursors, it is possible to change the PK output VARIANT utilising the ⇒ right cursor or **ENTER** (↵) push button. After placing the tag in the MONITORING field, it is possible to declare the relay output line continuity monitoring using the ⇒ right cursor or **ENTER** (↵) push button. When the tag is placed in the third line at a LS potential output VARIANT selection with the ⬇⬆ cursors, it is possible to change the LS output VARIANT utilising the ⇒ right cursor or **ENTER** (↵) push button. In order to save the

Installation, operation and disposal of waste batteries should be carried out in accordance with the battery manufacturer instructions. Used batteries should be passed for recycling in accordance with the regulations in force.

7 INSTALLATION

7.1 Terminal mounting

The terminal is designed for wall mounting, using three expansion anchor bolts of minimum diameter at 8 mm. The fastening holes spacing is shown in Fig. 7.1. The terminal installation shall be executed only without batteries.

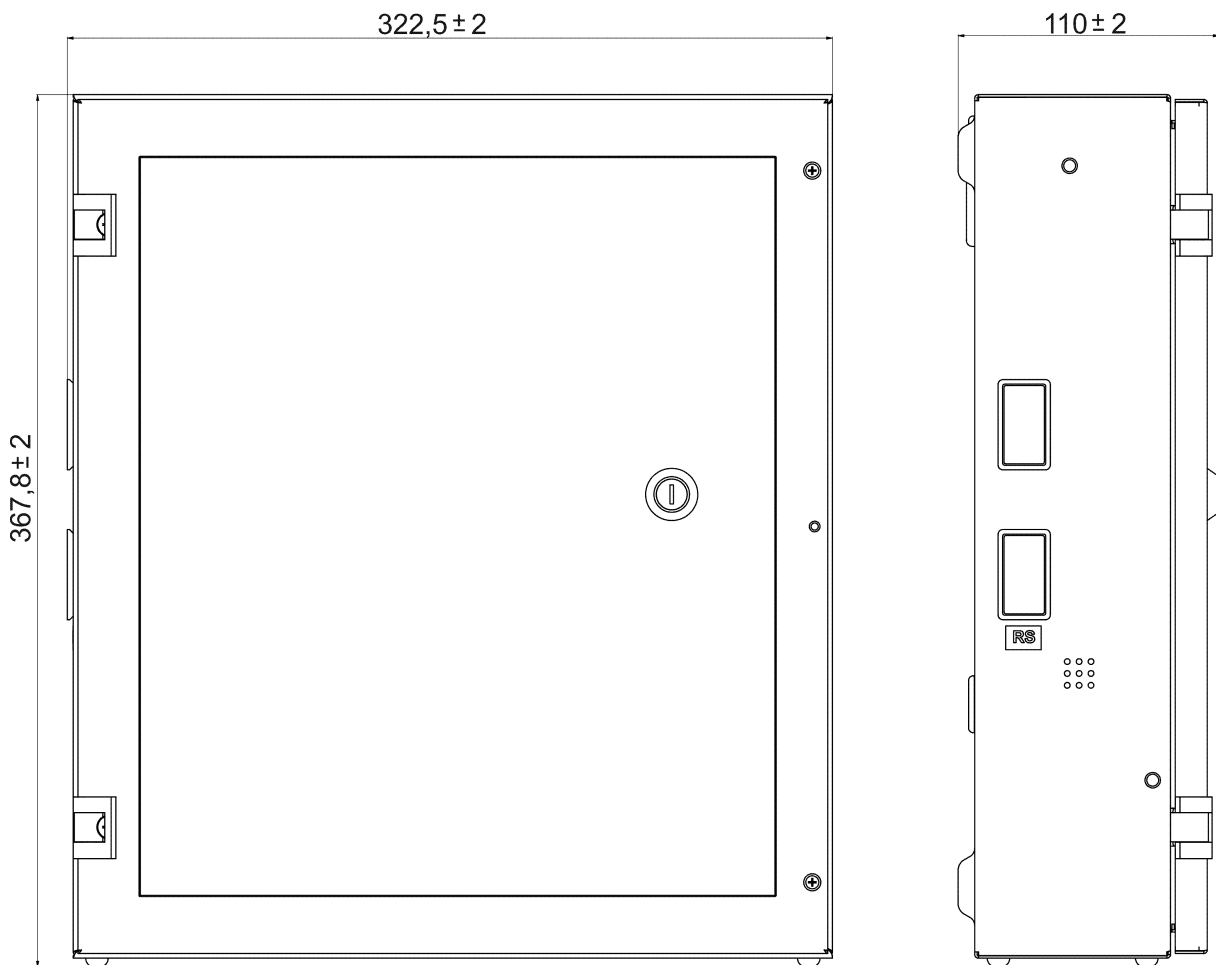

Fig. 7.1 TSR-4000 terminal overall view and basic dimensions

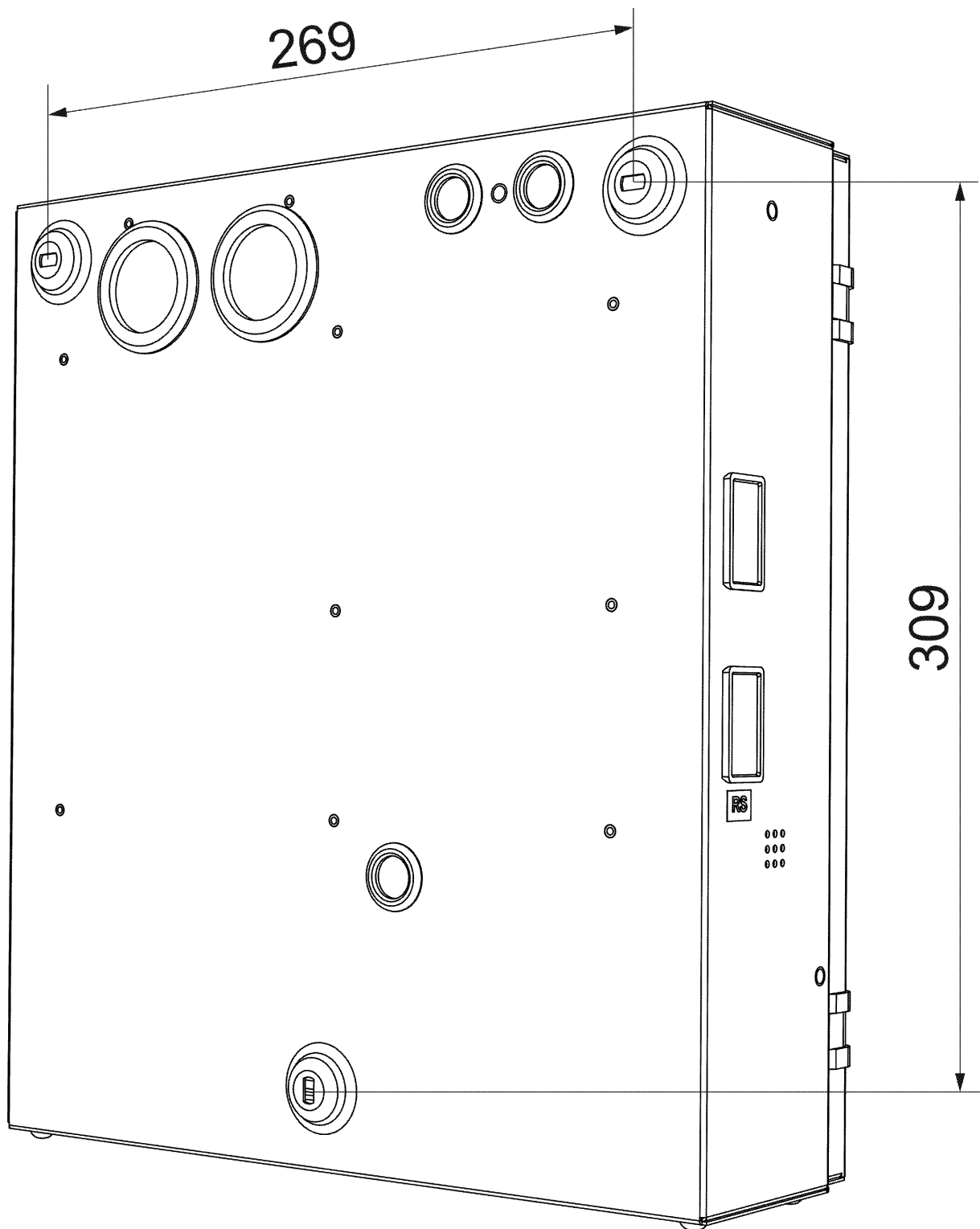

Fig. 7.2 TSR-4000 terminal mounting points

7.2 Input and output circuit connecting clamps

The terminal is equipped with a clamp block intended to connect conductors of external installations (relay output, potential output, RS-485 interface input and output), mains and reserve power supply. The cables can be introduced to the terminal from in-plaster (flushed) or on-plaster (surface) installation. They are introduced in the terminal upper part through round glands: separately the mains cables and low-voltage cables.

Mains power supply

The L, N and PE clamps are provided in the terminal to connect mains cables (230 V / 50Hz) and a protective conductor and those terminals are protected against incidental touch with a covering plate. The protection wire should be connected to a bolt placed on the terminal casing. The bolt is accessible after removing the protective plate covering the mains conductor's clamps.

Reserve power supply

The clamps marked '- AKU +' are provided to connect the battery cluster. The positive clamp is protected with a fuse of 2 A nominal value.

RS-485 bus

The clamps marked 'B IN1 A', 'B IN2 A', 'B OUT1 A' and 'B OUT2 A' are designed to connect the terminal with the control panel and other terminals. A conductor from the control panel and other TSR-4000 terminal should be connected to the 'B IN1 A' and 'B IN2 A' clamps, whereas the 'B OUT1 A' and 'B OUT2 A' clamps should be connected with a conductor to a consecutive TSR-4000 terminal. The screens of the input and output conductors should be connected in accordance with the recommendations of p. 7.3.1.

PKA non-potential monitored relay alarm output

The relay contacts, connected to the clamps marked as NO, PKA, NC, are galvanically isolated from the terminal circuits. A line connected to this output does not require any special provision as to screening.

PKU non-potential relay output

The relay contacts, connected to the clamps marked as NO, PKU, NC, are galvanically isolated from the terminal circuits. A line connected to this output does not require any special provision as to screening.

LS potential monitored output

The clamps marked as '+ LS -' are intended for connection of acoustic and optical signalling devices. In the case of this output activation, 24 V DC + 25 % - 15 % voltage will appear on its clamps. This voltage comes from the terminal power supply unit and reserve power supply battery. In case some current is drawn by external devices, the 72-hour operation time assumed for the terminal powered by the batteries in the case of mains voltage outage, will be proportionally reduced due to the current drawn.

Optic fibre converters power supply

In case the terminal is linked with the control panel with optic fibres, it is possible to use the voltage supplied to the clamps marked as '+ 24V -' to power the optic fibre converters. In the case of the converter current consumption (typically ca. 150 mA), the 72-hour operation time assumed for the terminal powered by the batteries in the case of mains voltage outage, will be proportionally reduced due to the current drawn.

7.3 The terminal connection with the control panel

The TSR-4000 terminal can be connected with the POLON 4900, POLON 4200 or POLON 4100 control panel in a conventional way using a two-core screened cable (1 RS-485 channel), two two-core screened cables (2 RS-485 channels) or optic fibres.

7.3.1 Connection by a screened cable

For the terminals connection with the control panel it is advised to use a screened copper twisted conductor. Installation cable **YnTKSYekw 1 x 2 x 0.8 mm** is recommended. The maximum cable length between the control panel and the last terminal should not exceed 1200 m.

The bus screen should be grounded from both sides, i.e. from the control panel side and also in the terminals it should be connected to the casing. In the case of a potential difference between the control panel housing and the terminal housing, or in the case of 'zeroing' application in the premises, the control panel or terminal output conductor screen should be fixed directly to the housing and the screen of the conductor entering the terminal should be connected to the housing through a 10 nF/1500 V capacitor.

In case two RS-485 transmission channels are used, the POLON 4000 system control panel should be equipped with the RS-485 hub with at least two output isolated channels, e.g. i-7513 manufactured by ICP DAS

Connection: one RS-485 channel (no redundancy)

In the case of a two-core conductor connection, it is necessary to:

- place the ZW6 jumper in 1 - 2 position (1 transmission channel – without redundancy),
- connect appropriate A and B input clamps (IN, IN1) of the terminal with appropriate A and B clamps in the control panel (A clamp is connected with A clamp as well as B clamp is connected with B clamp). Similarly, appropriate A and B clamps (OUT, OUT1) of one terminal should be connected with A and B clamps (IN, IN1) of the consecutive terminal, creating in this way a common RS-485 bus (Fig. 7.3.1.1 and Fig. 7.3.1.2).

In the last terminal, the RS-485 bus input conductor should be terminated with a 120 Ω end-of-line resistor (in order to eliminate possible signal reflections). The resistor installed in the terminal TPZ-4000 module can be utilized by switching the **ZW1** jumper into 1 - 2 position. The TPZ-4000 module **ZW4** jumper should be placed in 2 -3 position (CONVERTER NO).

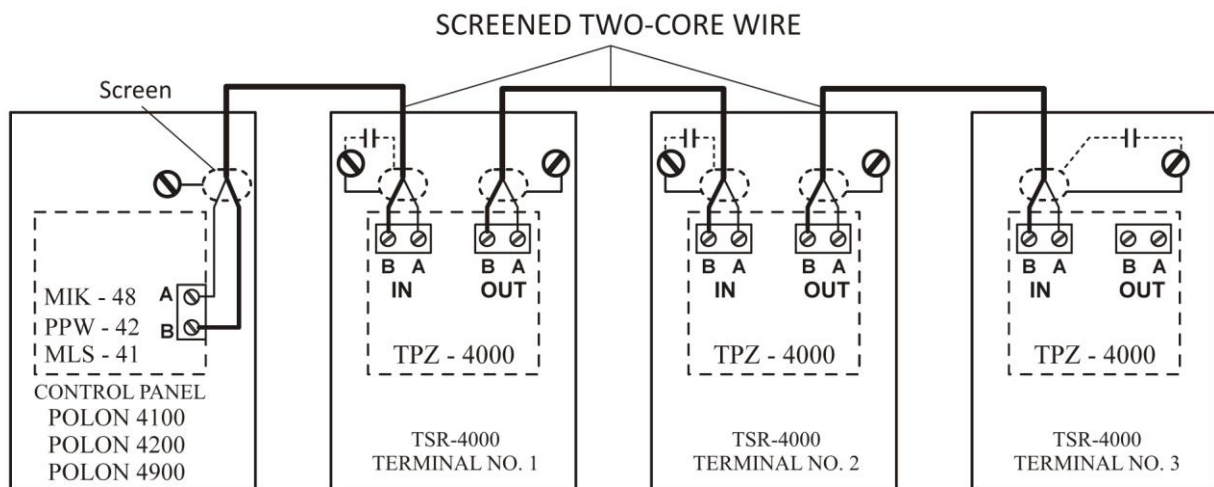

Fig. 7.3.1.1 TSR-4000 terminals connection with POLON 4000 system control panels using screened conductor (TPZ-4000 module)

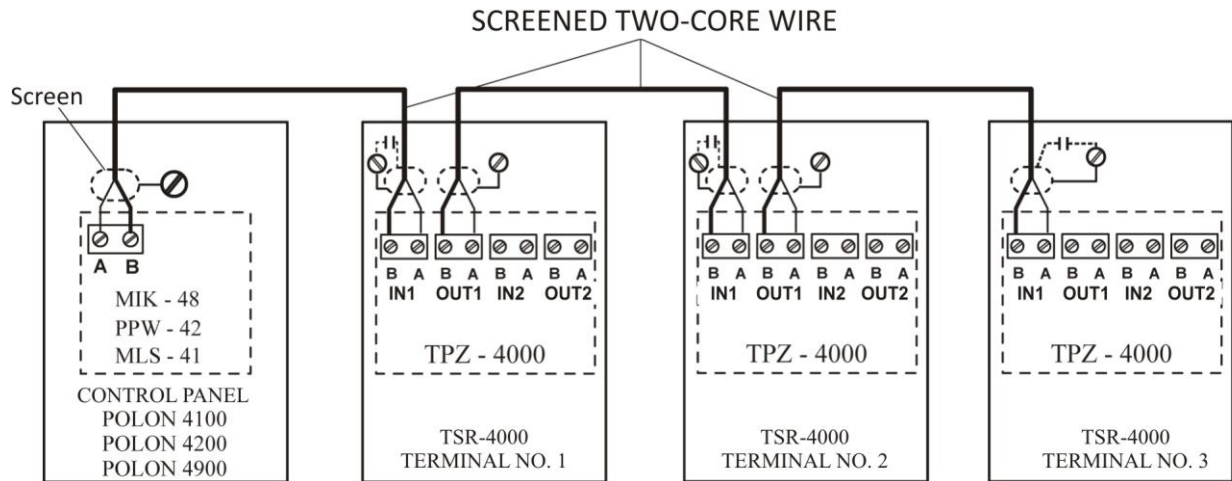

Fig. 7.3.1.2 TSR-4000 terminals connection with POLON 4000 system control panel using screened conductor (TPZ-4000 Ed.4 module) – one RS-485 channel

Connection: two RS-485 channels (redundancy)

In case terminals are connected with the control panel using two two-core conductor connection, it is necessary to:

- place the ZW6 jumper in 2 - 3 (2 transmission channels – redundancy),
- connect the terminal appropriate A and B input clamps (IN1) with appropriate clamps A1+, (D1+, DATA1+) and B1+ (D1-, DATA1-) in the RS 485 hub (e.g. i-7514U or i-7513 manufactured by ICP DAS Co., Ltd.) already connected to the control panel. Similarly, appropriate A and B clamps (OUT1) of one terminal should be connected with A and B clamps (IN1) of the consecutive terminal, creating in this way a common RS-485 bus for channel 1 (Fig. 7.3.1.3).
- connect the terminal appropriate A and B input clamps (IN2) with appropriate clamps A2+, (D2+, DATA2+) and B2+ (D2-, DATA2-) in the RS 485 hub (e.g. i-7514U or i-7513 manufactured by ICP DAS Co., Ltd.) already connected to the control panel. Similarly, appropriate A and B clamps (OUT2) of one terminal should be connected with A and B clamps (IN2) of the consecutive terminal, creating in this way a common RS-485 bus for channel 2 (Fig. 7.3.1.3).
-

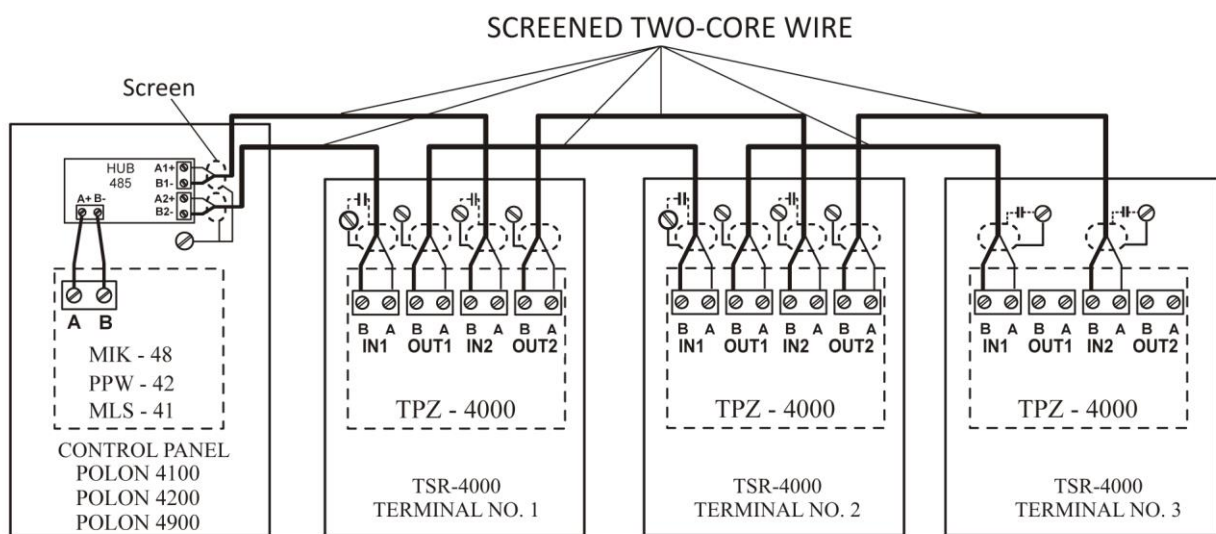

Fig. 7.3.1.2 TSR-4000 terminals connection with POLON 4000 system control panel using screened conductor (TPZ-4000 Ed.4 module) – two RS-485 channels

In the last terminal, the RS-485 bus input conductor should be terminated with a 120 Ω end-of-line resistor (in order to eliminate possible signal reflections). The resistor installed in the terminal TPZ-4000 module can be utilized by switching the **ZW1** and **ZW5** jumpers into 1 - 2 position. The TPZ-4000 module **ZW4** jumper should be placed in 2 -3 position (CONVERTER NO).

7.3.2 Connection with optic fibres

An optic fibre connection can be made utilizing one-mode or multi-mode optic fibres. In the case of such connection, both the POLON 4000 system control panel and the TSR-4000 terminals should be equipped with optic fibre converters. Particular below listed VARIANTS enable the connection execution using two one-mode or multi-mode optic fibres, or one one-mode optic fibre in the WDM technique for one RS-485 channel connection; four one-mode or multi-mode optic fibres, or two one-mode optic fibres in the WDM technique for two RS-485 channels connection (redundancy).

Connection: one RS-485 channel (no redundancy) – 2 optic fibres Fig. 7.3.2.1

POLON system control panel: 1 x **TR-55.2-1-2** converter (end-of-line),
 TSR-4000 terminal: 1 x **TR-55.2-2-2** converter (intermediate),
 1 x **TR-55.2-1-2** converter (end-of-line – last terminal),
 Optic fibres: **multi-mode 62.5/125 μm or 50/125 μm** (for 850 nm wave) terminated with SC type contacts,
one-mode 9/125 μm (for 1300/1550 nm wave) terminated with SC type contacts.

Connection: one RS-485 channel (no redundancy) – 1 optic fibre – WDM technique Fig. 7.3.2.2

POLON system control panel: 1 x **TR-55.2-1-6** converter,
 TSR-4000 terminal: 1 x **TR-55.2-2-7** converter (intermediate),
 1 x **TR-55.2-1-5** converter (end-of-line – last terminal),
 Optic fibres: **one-mode 9/125 μm** (for 1300/1550 nm view) terminated with SC type contacts.

Connection: two RS-485 channels (redundancy) – 4 optic fibres Fig. 7.3.2.3

POLON system control panel: 1 x RS-485 hub (e.g. i-7514U or i-7513 by ICP DAS Co., Ltd.),
 2 x **TR-55.2-1-2** converter (end-of-line),
 TSR-4000 terminal: 2 x **TR-55.2-2-2** converter (intermediate),
 2 x **TR-55.2-1-2** converter (end-of-line – last terminal),
 Optic fibres: **multi-mode 62.5/125 μm or 50/125 μm** (for 850 nm wave) terminated with SC type contacts,
one-mode 9/125 μm (for 1300/1550 nm wave) terminated with SC type contacts.

Connection: two RS-485 channels (redundancy) – 2 optic fibres – WDM technique Fig. 7.3.2.4

POLON system control panel: 1 x RS-485 hub (e.g. i-7514U or i-7513 by ICP DAS Co., Ltd.),
 2 x **TR-55.2-1-6** converter,
 TSR-4000 terminal: 2 x **TR-55.2-2-7** converter (intermediate),
 2 x **TR-55.2-1-5** converter (end-of-line – last terminal),
 Optic fibres: **one-mode 9/125 μm** (for 1300/1550 nm wave) terminated with SC type contacts.

Each converter is furnished with special latch for fast installation on a typical supporting rail (DIN EN 50022) located under the upper wall of the terminal. Converters should be supplied with + 24 V voltage which can be routed from the TPZ-4000 module. A diagram showing connections between the converter and TPZ-4000 module is included in Fig. 7.3.2.1 – Fig. 7.3.2.4. Optic fibre converters are equipped with the DIP-SWITCH (table 7.3.2) for the converter operation configuration. The

recommended position is described in item 1 in the table 7.3.2. Converters have a built-in end-of-line resistor (terminator).

In the case of transmission disruptions, it is necessary to connect a terminator utilizing a micro-switch placed on the converter side wall (in item 1 in the table 7.3.2). The terminator connection simultaneously causes initial line polarization in order to eliminate disruptions during the RS-485 bus silence; the TPZ-4000 module **ZW1** and **ZW5** jumpers should be placed in 2 - 3 position, whereas the **ZW4** jumper should be in 1 - 2 position (CONVERTER YES).

Note

An optic fibre converter powered by the terminal voltage causes the galvanic isolation breakdown. Therefore, it is recommended to power the converter from a galvanically isolated DC/AC transducer. Such the device should have the following impassable parameters: U_{in} 18...30 V, I_{out} min 400 mA, U_{out} 12...30 V, insulation resistance min. 1000 V DC.

Table 7.3.2 TR-55 converter DIP-SWITCH settings

DIP-SWITCH switch								Electric interface	Protection		
Terminating resistor				Protection		Interface type					
1	2	3	4	5	6	7	8				
OFF	OFF	OFF	OFF	OFF	OFF	OFF	OFF	Terminal switched off	RS-485 (2W)	switched off	
OFF	OFF	ON	ON	OFF	OFF	OFF	OFF	Terminal switched on			
OFF	OFF	OFF	OFF	OFF	OFF	ON	ON	Terminal switched off	RS-485 (4W)	switched off	
ON	ON	ON	ON	OFF	OFF	ON	ON	Terminal switched on			
OFF	OFF	OFF	OFF	OFF	OFF	OFF	ON	Terminal switched off	RS-422	switched off	
ON	ON	OFF	OFF	OFF	OFF	OFF	ON	Terminal switched on			
OFF	OFF	OFF	OFF	OFF	OFF	ON	OFF	RS-232		switched off	
X	X	X	X	ON	X	X	X	Electric interface type does not influence protection activity and should be chosen according to the requirements		master	switched on
X	X	X	X	ON	ON	X	X			master	
X	X	X	X	X	ON	X	X			slave	

Protection – applicable only to the devices with two optical ports; the 5 and 6 switches position

does not influence a device with one optical port;

X – no impact on configuration.

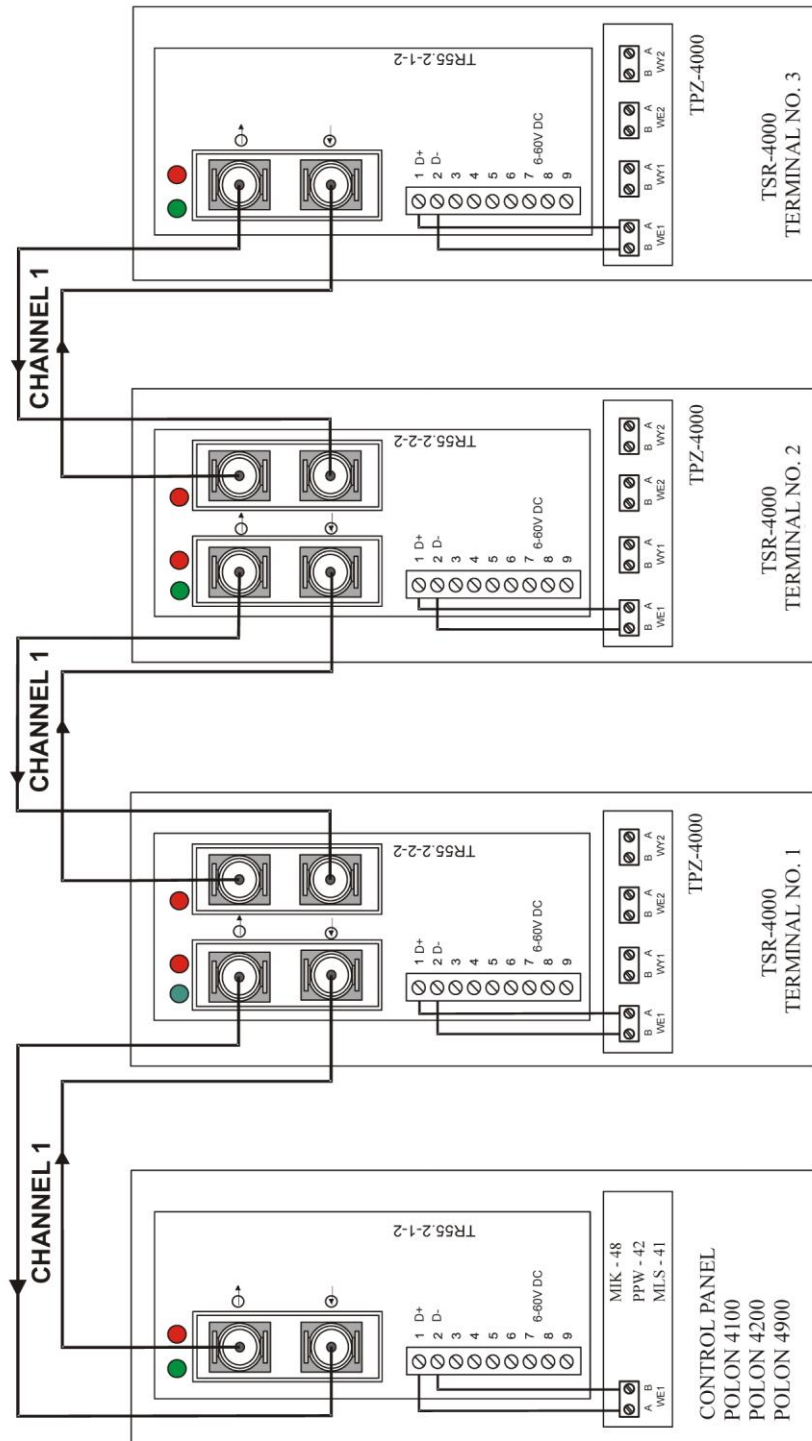

Fig. 7.3.2.1 TSR-4000 terminals connection to POLON 4000 system with one- or multi-mode optic fibre– 1 channel (2 fibres)

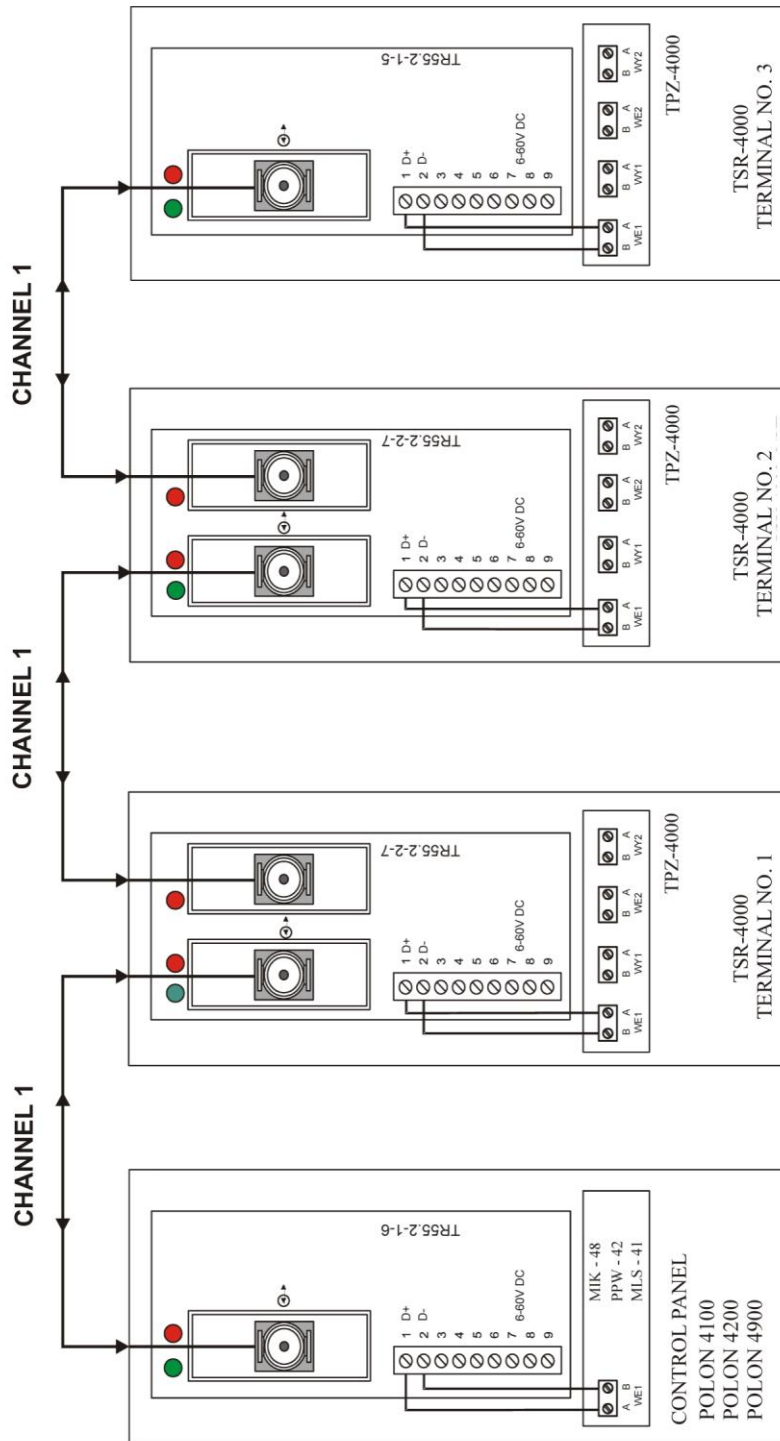

Fig. 7.3.2.2 TSR-4000 terminals connection to POLON 4000 system with one-mode optic fibre in WDM technique – 1 channel (1 fibre)

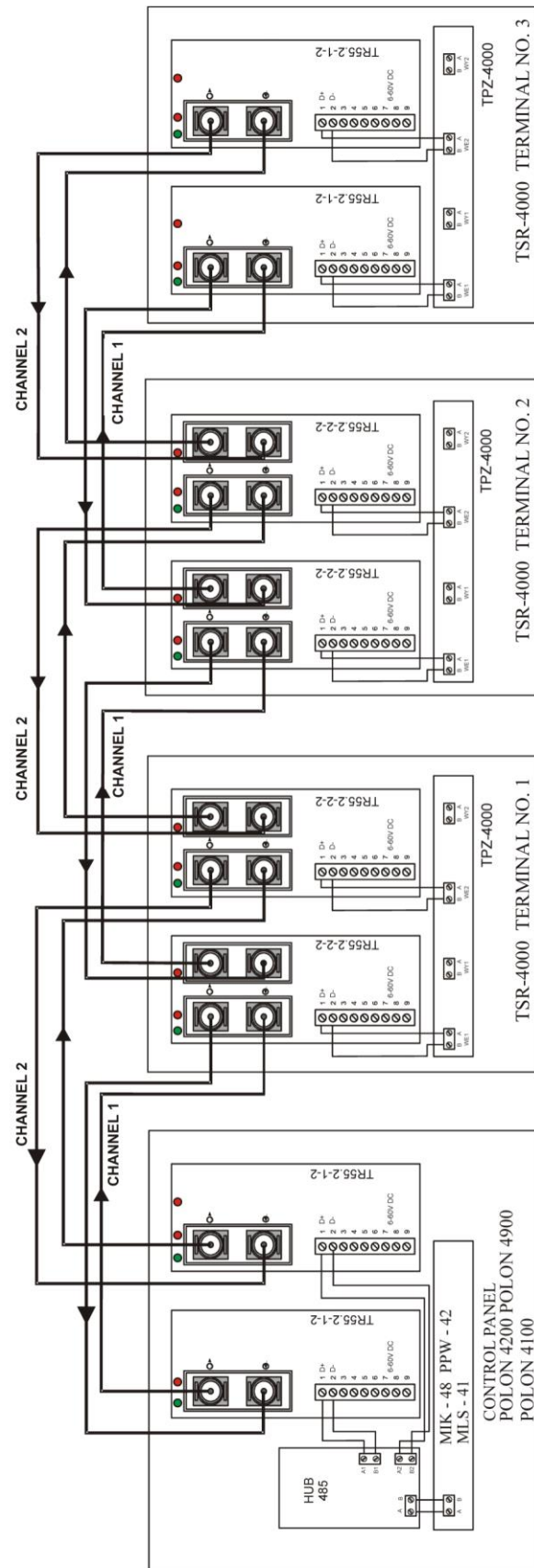

Fig. 7.3.2.3 TSR-4000 terminals connection to POLON 4000 system with one- or multi-mode optic fibre – 2 channels (4 fibres)

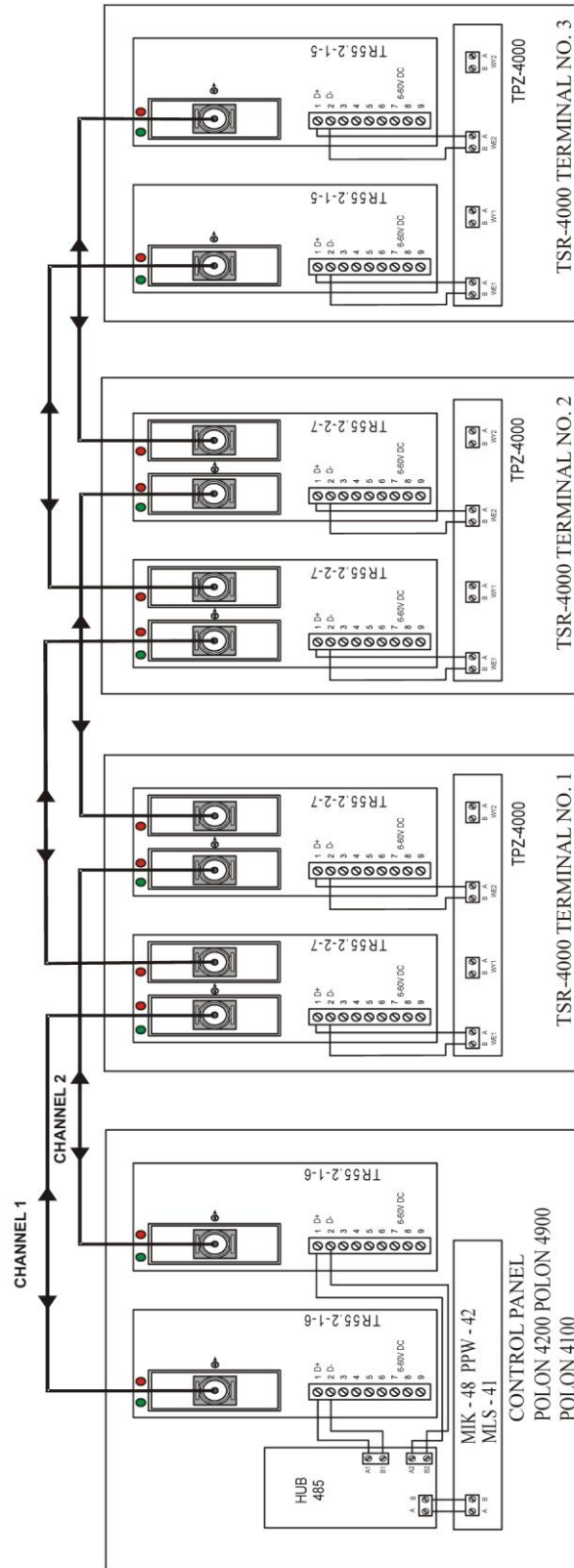

Fig. 7.3.2.4 TSR-4000 terminals connection to POLON 4000 system with one-mode optic fibre in WDM technique – 2 channels (2 fibres)

8 OPERATION AND MAINTENANCE

8.1 Proper operation rules

The terminal unfailing operation depends on maintaining appropriate operating conditions, power supply voltage, battery condition and periodical inspections performance.

The periodical inspections should be carried out by an authorised maintenance technician who was appointed by the user to perform maintenance works. Any damage should be immediately reported to the technician.

In the case of fuse replacement, attention should be paid to their nominal values. It is not allowed to replace a burnt fuse with a spare one of a greater nominal value, since it can result in the unit damage.

The following fuses are used in the TSR-4000 terminals:

- | | | |
|---------------|-----------------|--------------------------------------|
| - BS / 500 mA | type T500L250 V | terminal primary protection, |
| - B1 / 2 A | type F2L250 V | battery cluster circuits protection, |
| - B2 / 2 A | type F2L250 V | 30 V converter protection, |
| - B3 / 630 mA | type F630L250 V | signalling line protection. |

8.2 Periodic inspections and maintenance rules

The TSR-4000 terminal periodical inspections, according to the PN-E-08350-14 standard, should be carried out at least once per year.

Every 6 months it recommended to check the condition of protective grounding cable or zeroing cable with the terminal housing and to clean battery clamps.

The battery charging level should be checked at least once a year. For this purpose, it is necessary to disconnect the mains power supply with the mains switch for approx. 2 hours and, after re-connection, to check if, within a period not longer than 5 hours, the mains power supply device recharges the battery panel and if the terminal automatically switches to the buffering mode.

A properly operating and regularly inspected terminal does not require any special maintenance works. It is recommended to regularly remove dust from the terminal outer surfaces.

9 PACKING, STORAGE AND TRANSPORTATION

9.1 Packing

The terminal is placed in a unit package that reduces free movement possibility and eliminates damages during handling and transportation. The following data are marked on the package:

- the manufacturer's name or trade mark;
- the name and type of the terminal;
- the terminal mass.

Additionally, the following marking is placed on the package:

“CAUTION FRAGILE”, “UPPER SIDE, DON'T TURN OVER”, “KEEP DRY” or equivalent marks according to the PN-85/O-79252 Polish Standard.

9.2 Storage regulations

The terminal should be stored in closed premises at a temperature between +5 °C and +40 °C and relative humidity not exceeding 80 %, free of corrosive vapours and gases. In case the terminal is stored for a longer period, it is necessary to connect it to power supply for at least 1 hour and test its proper operation every 6 months.

During storage the terminal should not be exposed to heat radiation: direct sunlight or heating devices.

9.3 Transport principles

The terminals, packed as mentioned in p. 9.1, should be carried by closed transport means, taking into consideration the transport recommendations marked on the package, and protecting against sharp shocks and avoiding ambient temperature exceeding the –25 °C to +55 °C range.

10 INSTRUCTIONS FOR PROPER TERMINAL OPERATION AFTER INSTALLATION

Pre-launch tasks

- Execution of the installation of transmission, power supply and control lines of executive devices (paragraph INSTALLATION of this OMD) in accordance with the design
- Installation of executive devices
- Terminal mounting
- Connecting the line with the terminal connectors, except for 230 V mains cables

Electrical connection inspection

- Examine the correct position of configuration jumpers on all terminal packages,
- Connection correctness verification of the line wires with the package connectors in the terminal, with attention to polarity + , -
- Checking the connection of the output resistors in the last sockets of the supervised lines (executive and control)
- In the case of unused lines (executive and control) – examine the connection of end resistors at the terminals of these lines in the terminal packages
- Inserting the batteries
- Series connection of the 2 x 12V batteries with attention to compliance of the polarity markings +,- on battery terminals and connectors

Activation

- Mains power supply and PE cable connection. **NOTE! Dangerous voltage!**
- Starting the terminal by switching the circuit breaker to position I
- Reading the damage detected by the terminal and removing any errors in the installation
- Setting the optimal configuration parameters of the terminal using the functions described in the relevant sections of this OMD
- Operation inspection of devices cooperating with the terminal
- Inspecting the transmission of signals with the POLON 4000 system control panel

Initiation process is completed if the above-mentioned tasks have been performed and the proper functioning of all system devices and the operation of the terminal in the supervision state have been successful (without fault notification/command) – the terminal can be handed over to the user.



POLON-ALFA S.A.

POLAND 85-861 Bydgoszcz, ul. Glinki 155 | www.polon-alfa.pl
EXPORT DEP. phone no. +48 52 36 39 278, email: export@polon-alfa.pl
SERVICE DEP. phone no. +48 52 36 39 390, email: serwis@polon-alfa.pl